

● 部分蜗杆减速器产品图片

Part of the worm accelerator product Image



RV蜗杆减速器转向示意图
RV direction of rotation diagram



NRV

NRV+NMRV

● 零件爆炸图及名称

Exploded view & name of parts

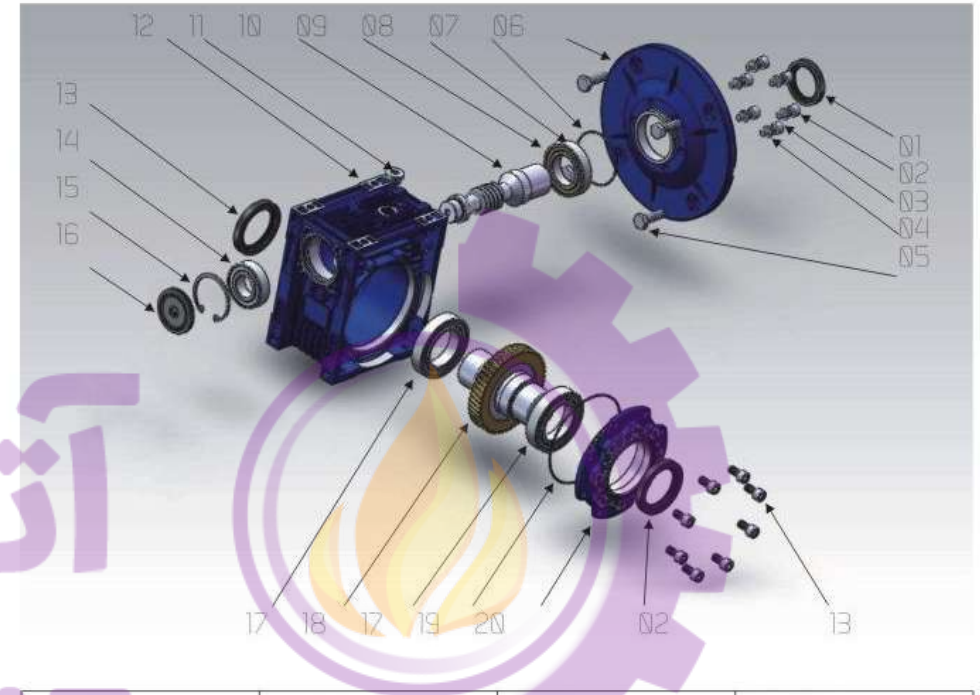

01. 油封	11. 油塞	01. Oil seal	11. Oil plug
02. 内六角螺钉	12. 箱体	02. Inner hex screw	12. Casing
03. 螺母	13. 油封	03. Nut	13. Oilseal
04. 弹性垫圈	14. 轴承	04. Spring washer	14. Bearing
05. 六角头螺栓	15. 孔用挡圈	05. Hex screw	15. Hole-circlip
06. 输入法兰	16. 闷盖	06. Input flange	16. Cover
07. O形圈	17. 轴承	07. O-ring	17. Bearing
08. 调整垫片	18. 蜗轮	08. Adjust spacer	18. Worm wheel
09. 轴承	19. O形圈	09. Bearing	19. O-ring
10. 孔输入蜗杆	20. 输出端盖	10. Hole input worm	20. Output cover

● 选用指南 Selection guide

- 1、本系列减速器为普通设计，供在环境温度不超过-10℃~+40℃,海拔不超过1000米的场合下使用，超出此范围须要咨询我技术部门。
- 2、订货时，根据需要的转速、转矩和工作系数合理选择机型，工作系数的选择见下表，工作转矩乘以工作系数即为减速机应有的转矩。写明型号，注明安装型式。如配电机或特殊订货，请注明并与本公司协商。
- 3、蜗杆的输入转速不大于1500r/min。
- 4、选择带无级变速器的机型，为充分显示本机型的优良特性，常用转速应选择变速范围的中间值。
- 5、带无级变速器的机型，严禁停机调速。
订货时请尽量选择本目录内的标准产品，如果有特殊要求，请在合同上详细说明；如需要单向或双向输出轴以及电机接线盒规定位置时均须注明清楚。
- 6、减速器使用的润滑油参照有关润滑油章节；无级变速器使用的润滑油为：Ub-3无级专用油。
- 7、减速器应装在有遮篷的交通工具上运输，在运输过程中要纺织野蛮装卸，应避免剧烈的碰撞和抛掷，在储运和储存过程中，须注意防潮。
- 8、验收发现包装箱损坏时要仔细检查，确实未损坏才可投入使用。
- 9、减速器应储存在通风干燥的地方，应避免与腐蚀性的物品共储，储存超过一年应检查油封的密封性能及电机绝缘性能，合格后方可使用。
- 10、本厂负责维修指导。

- 1、The reducer series is universal designed, suitable with ambient temperature >-10℃~<+40℃ and altitude<1000M, please consult the engineer department if the application beyond this situations.
- 2、Please select the right reducer type as the request speed, torque and service factor. Service factor is below. Reducer torque=working torque service factor. Remark the model, mounting pattern, please consult if you request motor or others.
- 3、The input speed of worm gearbox≤1500r/min.
- 4、To make sure the reducer's good specifications, the normal speed of worm gearbox with variator is better to be median of the varying range when
- 5、Don't adjust the speed of reducers combination with variator.
- 6、Please remark on the contract if you have special request, we suggest to select the standard type. Please note clearly if you need single or double output shaft or request the motor joint box place.
- 7、Please select the lubricant as the lubricant table; the lubricant of variator is : Ub-3.
- 8、Transport the reducer with awning, do not load and unload violently, avoid crash and throw, protect from d-amp.
- 9、Please check the reducer specification before using if the packing is broken.
- 10、Stock in the ventilated and dry places, avoid corrosion. Please check the oil seal, the insulation of motor if the stock more than 1 year before using.
- 11、We are responsible for maintenance.

● 工作系数表 Service factor table

均衡负荷、连续运转、无正反转、惯性小 Steady load, continuous running, no change direction of operation, weak inertia											
每天工作时间	启动频率 (次/小时) Start-up frequency (Starts/hour)										
working time per day	5	10	20	30	40	50	60	70	80	90	100
2小时	0.8	0.81	0.83	0.86	0.88	0.9	0.92	0.94	0.96	0.98	1
8小时	1	1.01	1.03	1.06	1.08	1.1	1.12	1.14	1.16	1.18	1.2
16小时	1.2	1.21	1.23	1.26	1.28	1.3	1.32	1.34	1.36	1.38	1.4
24小时	1.5	1.51	1.53	1.56	1.58	1.6	1.62	1.64	1.66	1.68	1.7

轻微冲击、间隙运动或有正反转、惯性适中 Moderate shocks or intermission movement or direction change, general inertia											
每天工作时间	启动频率 (次/小时) Start-up frequency (Starts/hour)										
working time per day	5	10	20	30	40	50	60	70	80	90	100
2小时	1	1.02	1.04	1.07	1.09	1.12	1.15	1.17	1.2	1.22	1.25
8小时	1.2	1.22	1.24	1.27	1.29	1.31	1.35	1.37	1.4	1.42	1.45
16小时	1.4	1.42	1.44	1.47	1.49	1.52	1.55	1.57	1.6	1.62	1.65
24小时	1.7	1.72	1.74	1.77	1.79	1.82	1.85	1.87	1.9	1.92	1.95

较大冲击、间隙运动或有正反转、惯性大 Heavy shocks or intermission movement or direction change, stronger inertia											
每天工作时间	启动频率 (次/小时) Start-up frequency (Starts/hour)										
working time per day	5	10	20	30	40	50	60	70	80	90	100
2小时	1.2	1.22	1.25	1.28	1.31	1.34	1.38	1.4	1.44	1.47	1.5
8小时	1.4	1.42	1.45	1.48	1.51	1.54	1.58	1.6	1.64	1.67	1.7
16小时	1.6	1.62	1.65	1.68	1.71	1.74	1.78	1.8	1.84	1.82	1.9
24小时	1.9	1.92	1.95	1.98	2.01	2.04	2.08	2.1	2.14	2.17	2.2

● RV 系列蜗杆减速器型号表示法 (一)
RV worm gearbox model designation (一)



示例 Example



● RV 系列蜗杆减速器型号表示法 (二)
RV worm gearbox model designation (二)

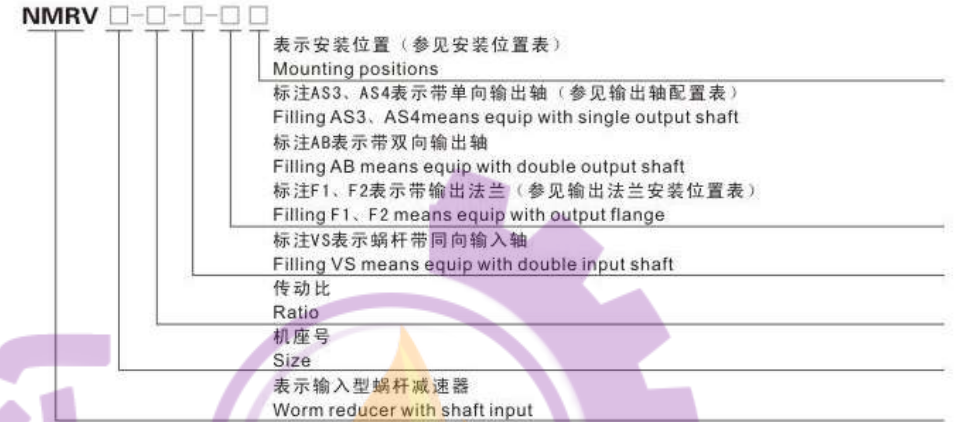

示例 Example

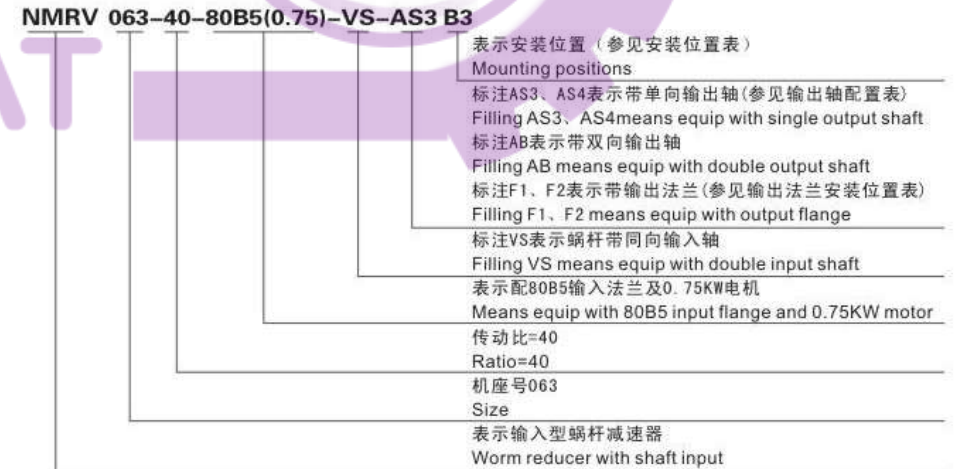

● 安装位置

Mounting positions

NMRV安装位置表

NMRV Mounting positions

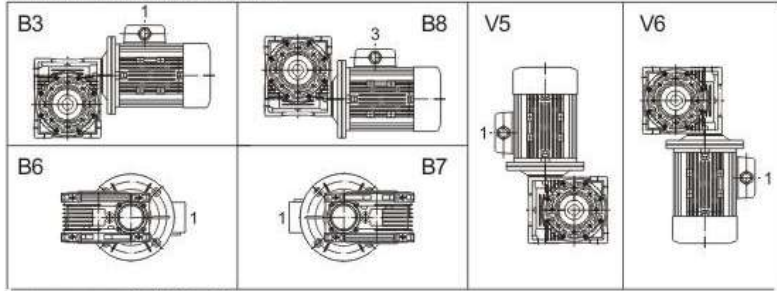

PC+NMRV安装位置表

PC+NMRV Mounting positions

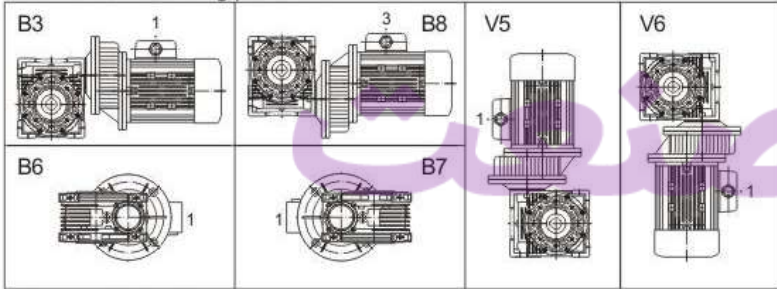

二级减速器安装位置表

NMRV+NMRV Execution

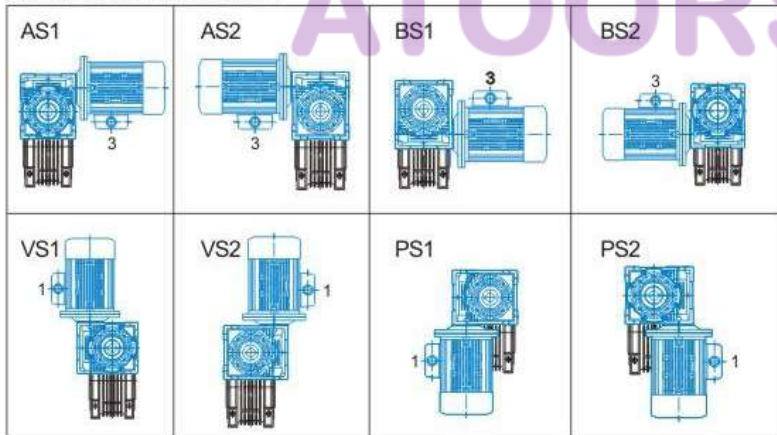

● 安装位置

Mounting positions

NMRV+无级调速器安装位置表

NMRV+Variator mounting position

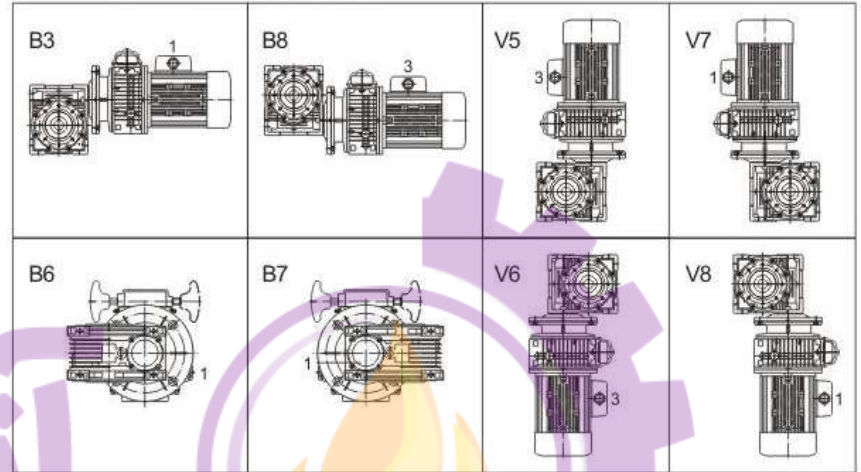

输出轴配置表

Position of output shaft

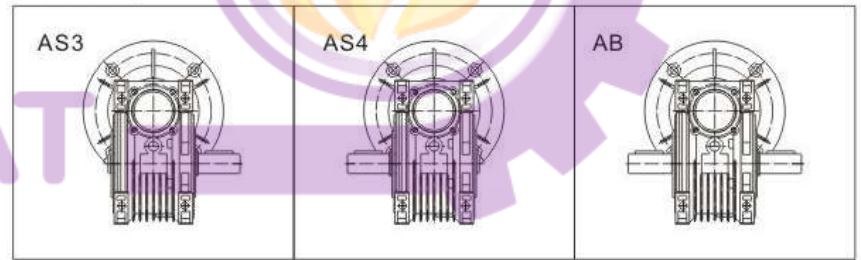

输出法兰安装位置表

Output flange installations

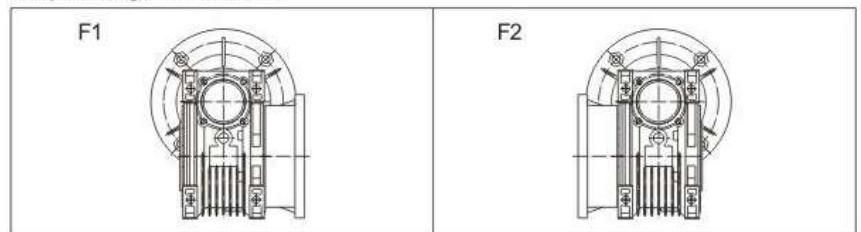

扭力臂配置
Torque arm mounting position

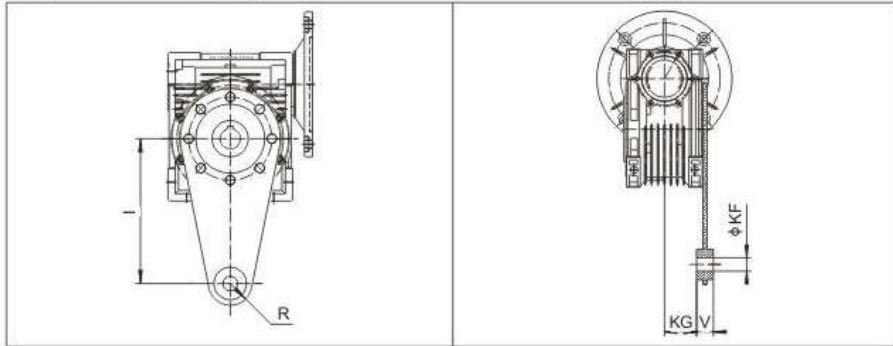

扭力臂尺寸表
Torque arm dimension

机座号	030	040	050	063	075	090	105	110	130	150
I	85	100	100	150	200	200	250	250	250	250
R	15	18	18	18	30	30	35	35	35	35
V	14	14	14	14	25	25	30	30	30	30
KF	8	10	10	10	20	20	25	25	25	25
KG	24	31.5	38.5	49	47.5	57.5	62	62	69	84

电机接线盒位置(从电机风扇罩向输出端看)
Motor thermal box position(viewed output shaft from fan cowl of motor)

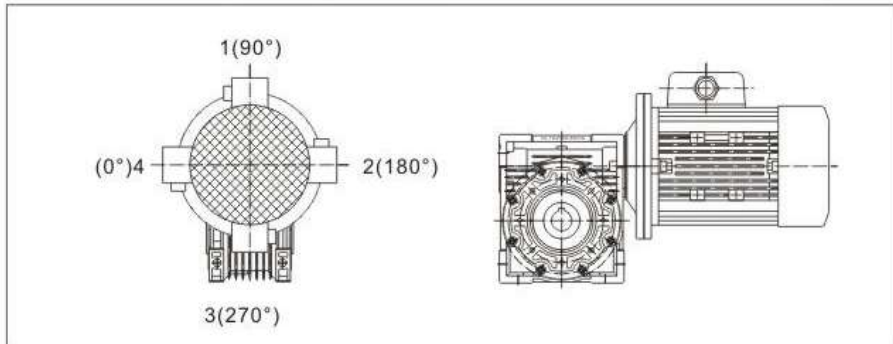

● 安装位置
Mounting positions

NRV蜗杆减速器外形图
NRV External outline dimensional drawing

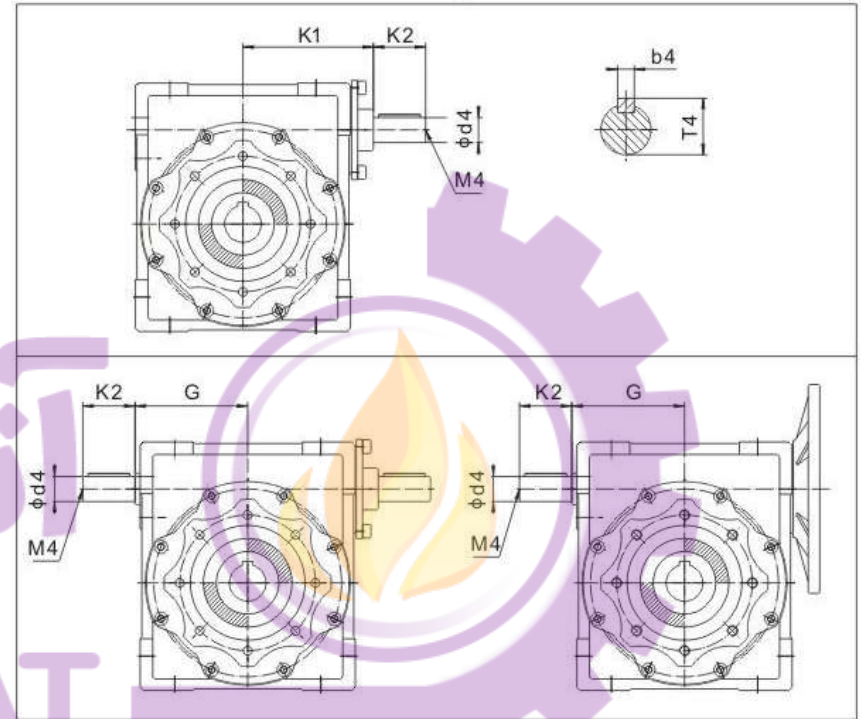

输入轴及VS蜗杆同向输入轴尺寸表
Input shaft vs worm coaxial input size table

机座号	030	040	050	063	075	090	105	110	130	150
K1	51	60	74	87	105	105	142	142	162	195
K2	20	23	30	40	50	50	60	60	80	80
G	45	53	64	75	90	108	135	135	155	175
d4	9	11	14	19	24	24	28	28	30	35
b	3	4	5	6	8	8	8	8	8	10
t4	10.2	12.5	16	21.5	27	27	31	31	33	38
M4	--	M5x10	M6x12	M8x16	M10x20	M10x20	M10x20	M10x20	M10x20	M12x20

● NMRV外型尺寸图
NMRV outline dimensional drawing

NMRV030外型尺寸图 NMRV030 outline dimensional drawing

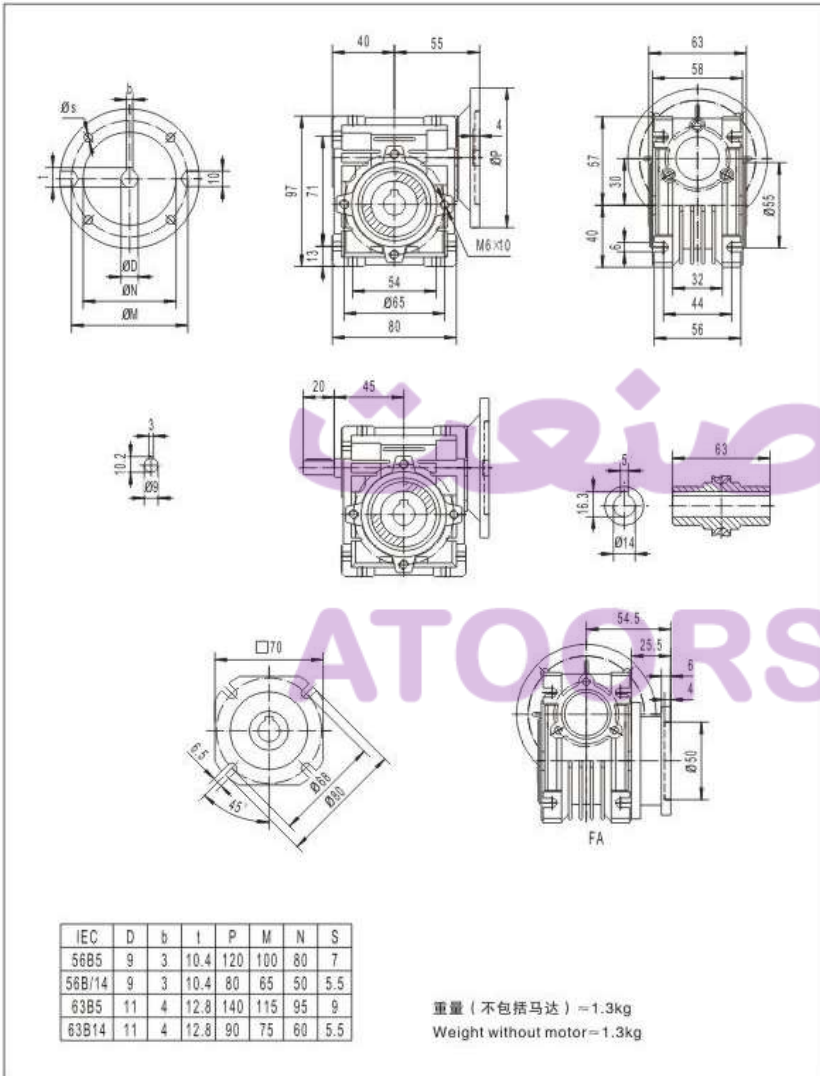

● NMRV外型尺寸图
NMRV outline dimensional drawing

NMRV040外型尺寸图 NMRV 040 outline dimensional drawing

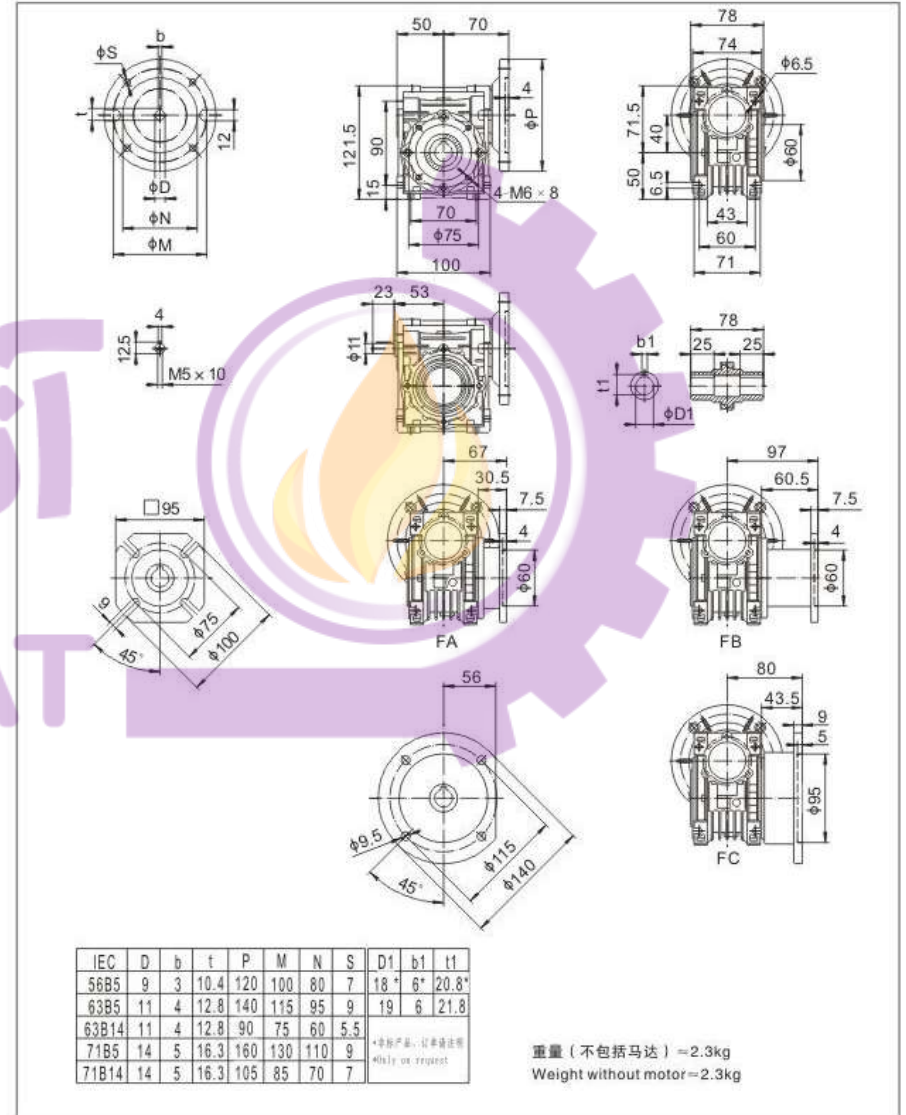

● NMRV外型尺寸图
NMRV outline dimensional drawing

NMRV050外型尺寸图 NMRV 050 outline dimensional drawing

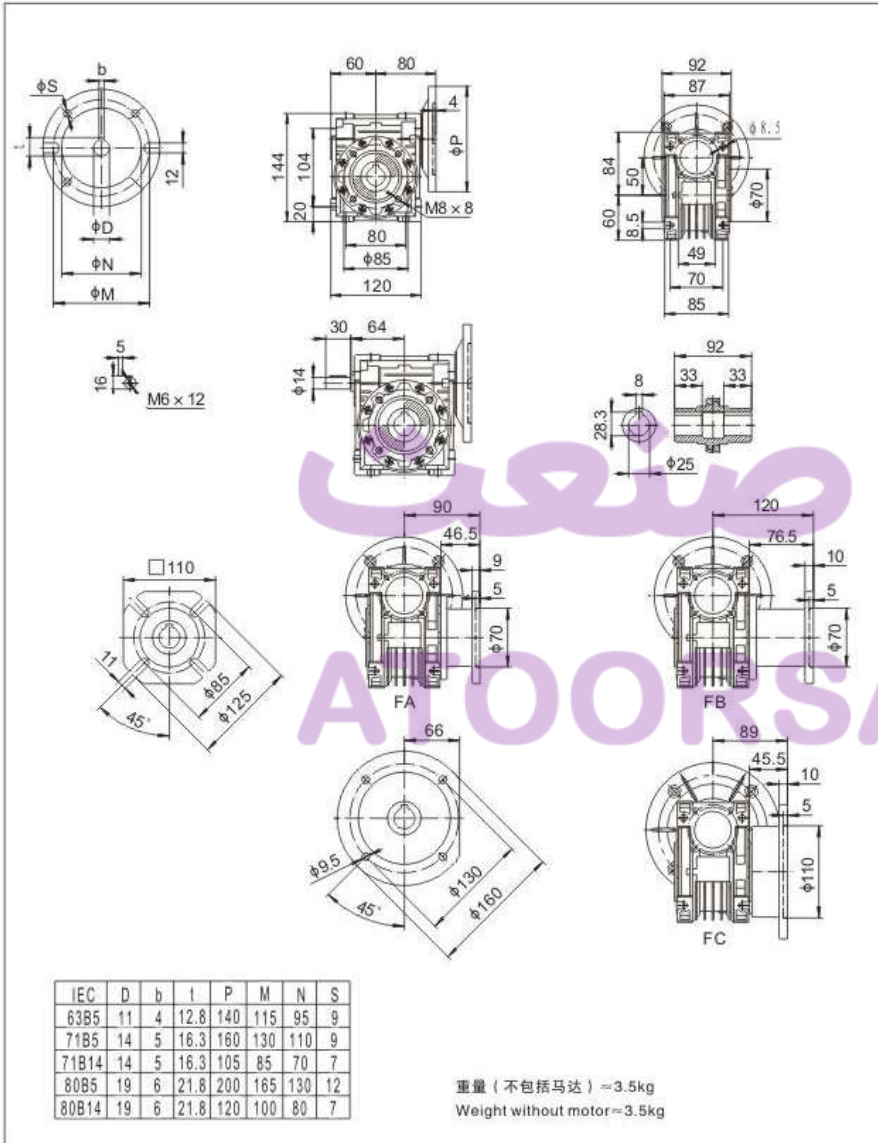

● NMRV外型尺寸图
NMRV outline dimensional drawing

NMRV063外型尺寸图 NMRV 063 outline dimensional drawing

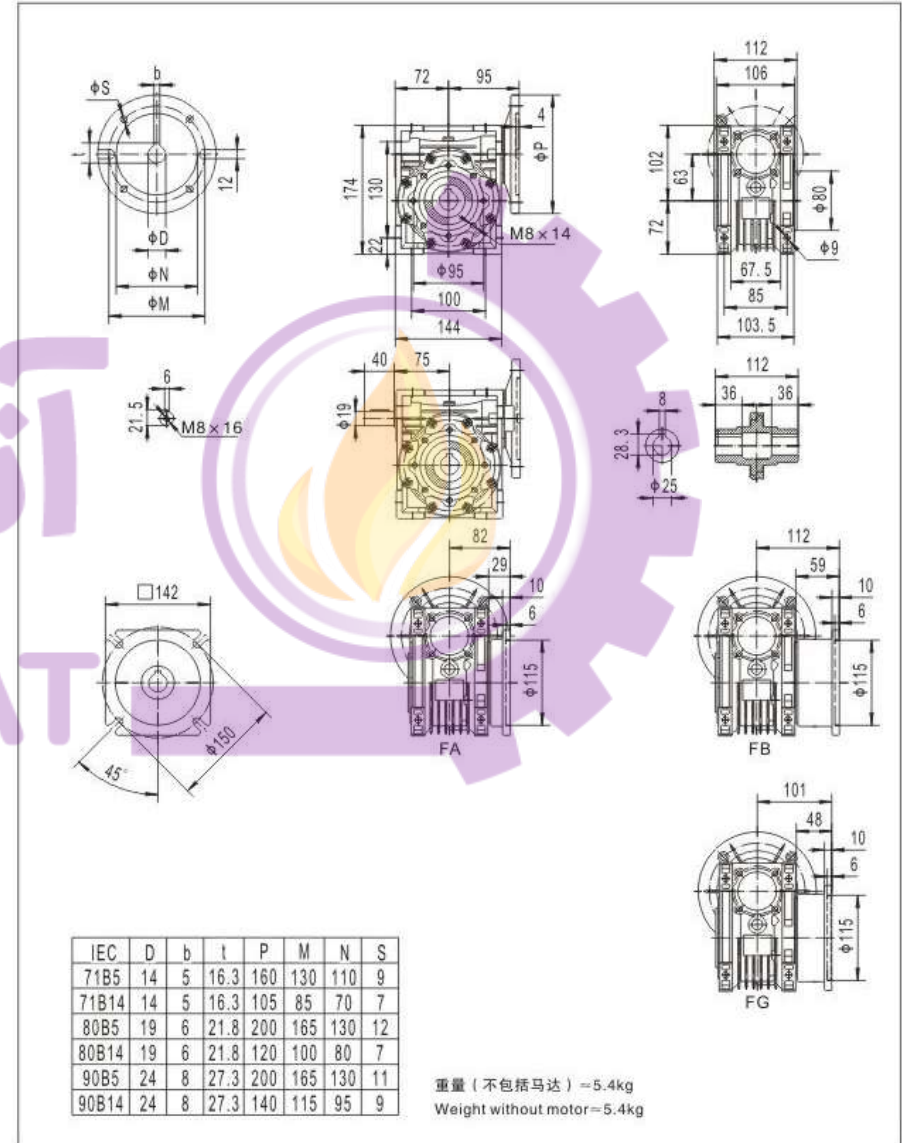

● NMRV外型尺寸图
NMRV outline dimensional drawing

NMRV075外型尺寸图 NMRV 075 outline dimensional drawing

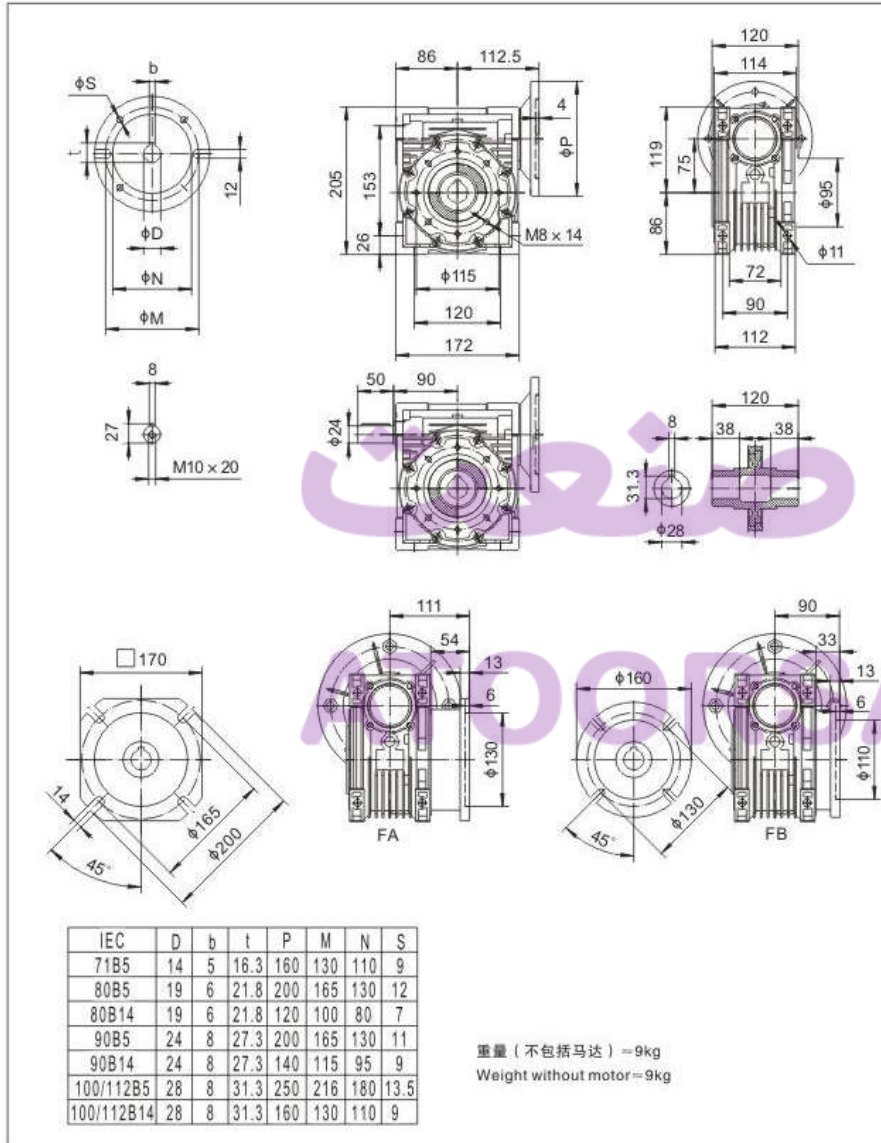

● NMRV外型尺寸图
NMRV outline dimensional drawing

NMRV090外型尺寸图 NMRV 090 outline dimensional drawing

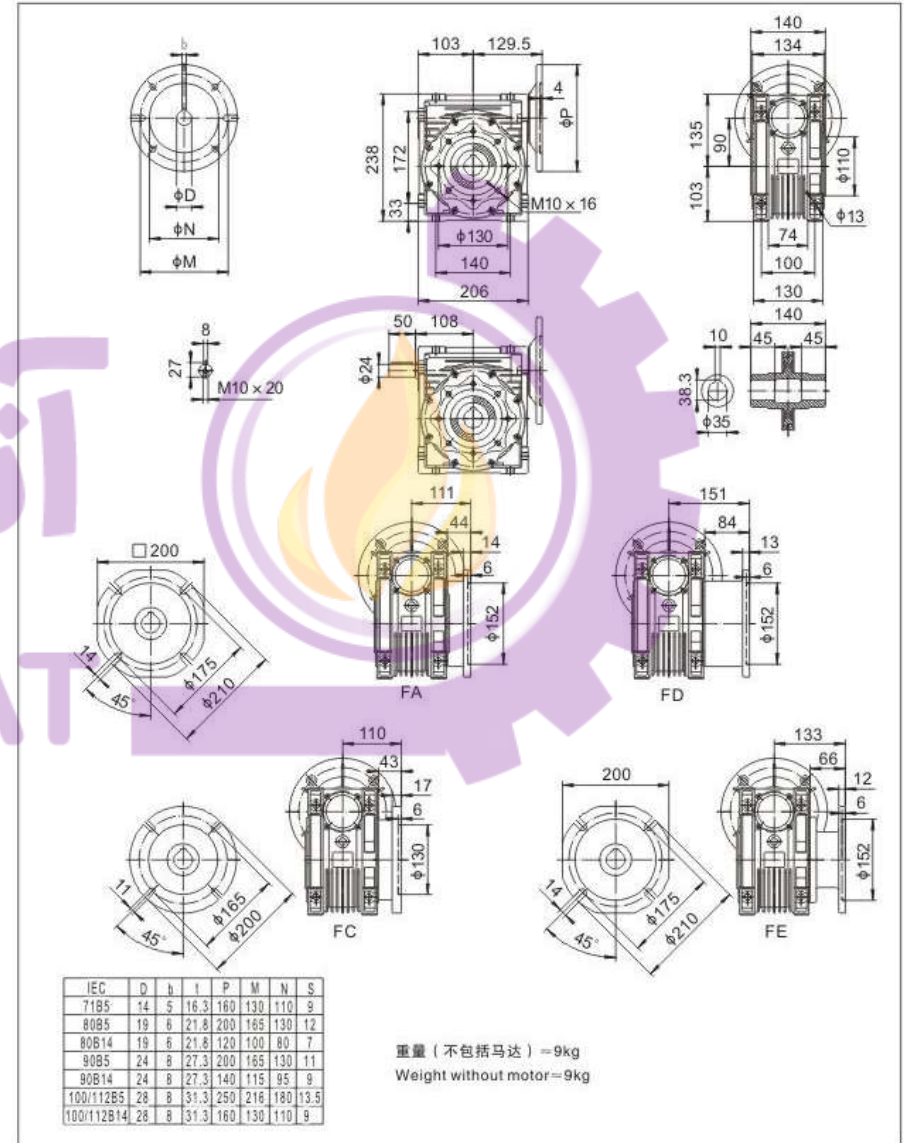

● NMRV外型尺寸图
NMRV outline dimensional drawing

NMRV105外型尺寸图 NMRV 105 outline dimensional drawing

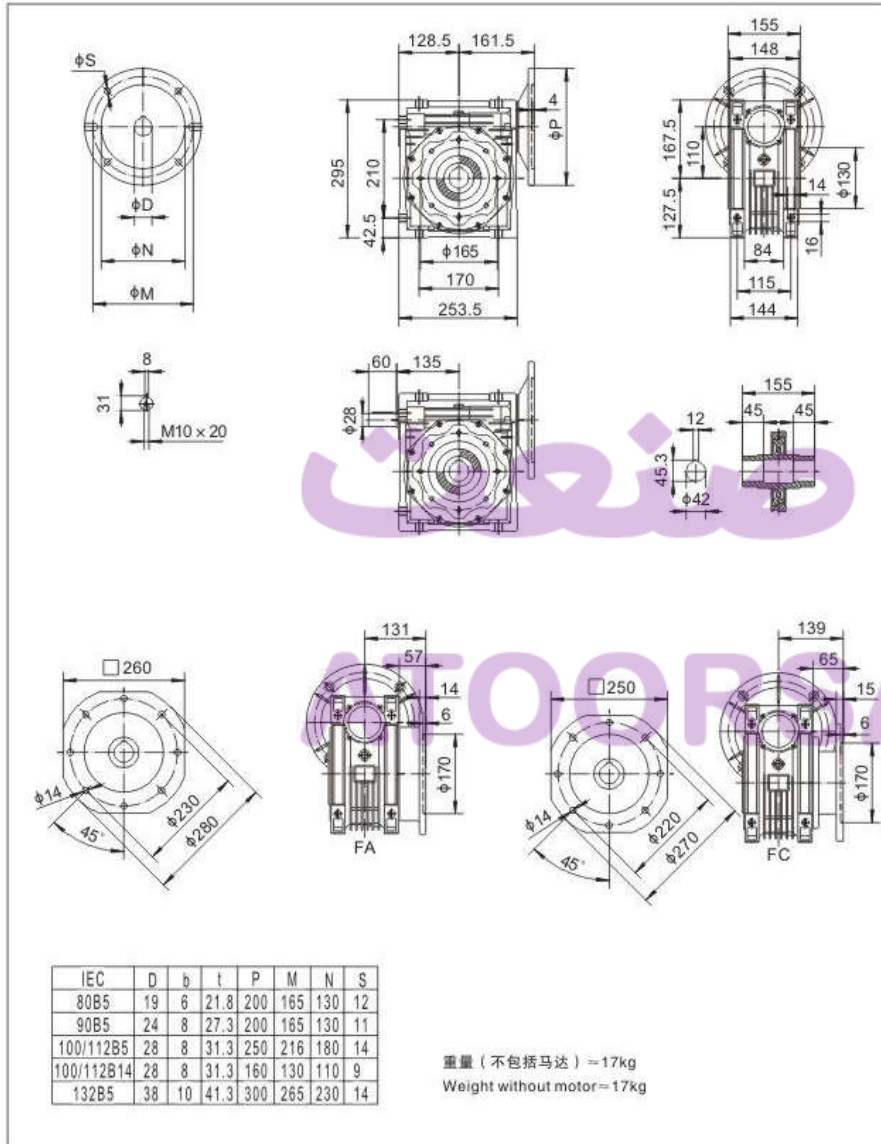

● NMRV外型尺寸图
NMRV outline dimensional drawing

NMRV110外型尺寸图 NMRV 110 external dimensions diagram

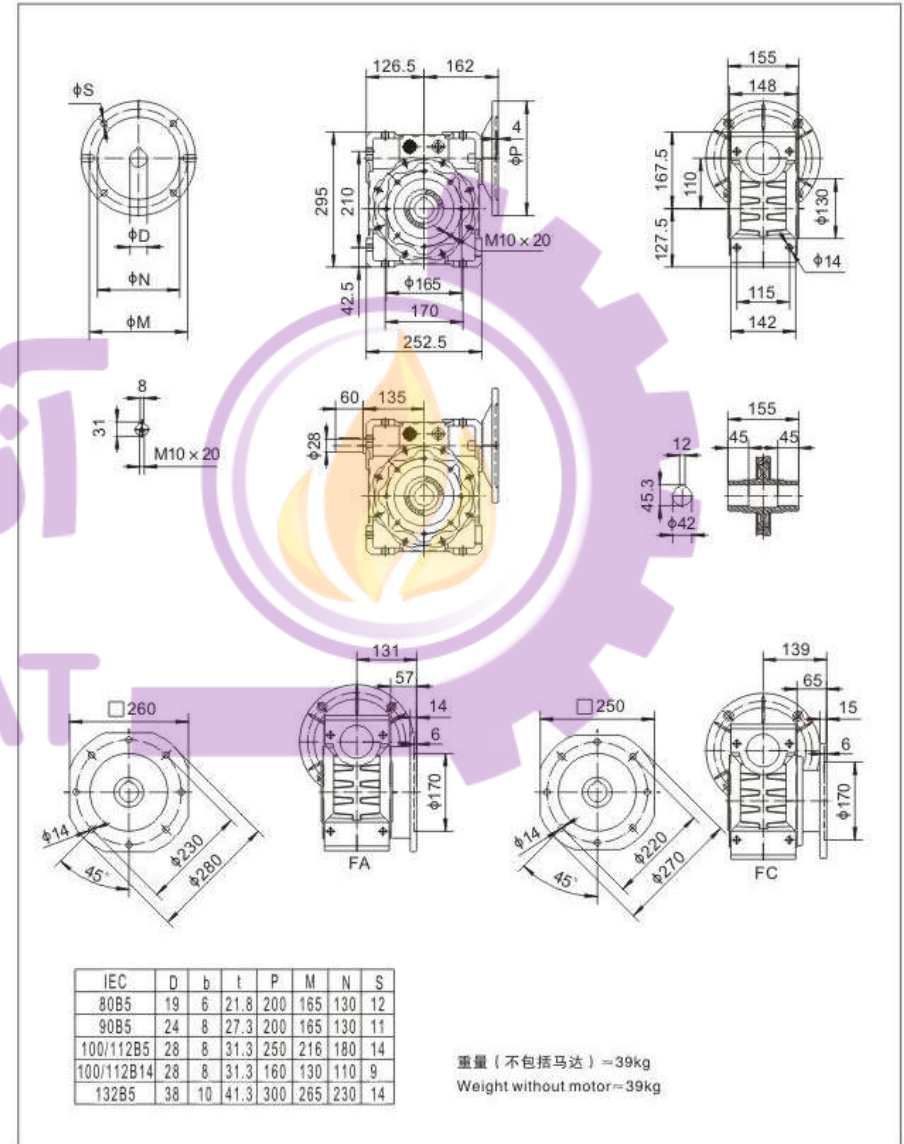

● NMRV外型尺寸图
NMRV outline dimensional drawing

NMRV130外型尺寸图 NMRV 130 external dimensions diagram

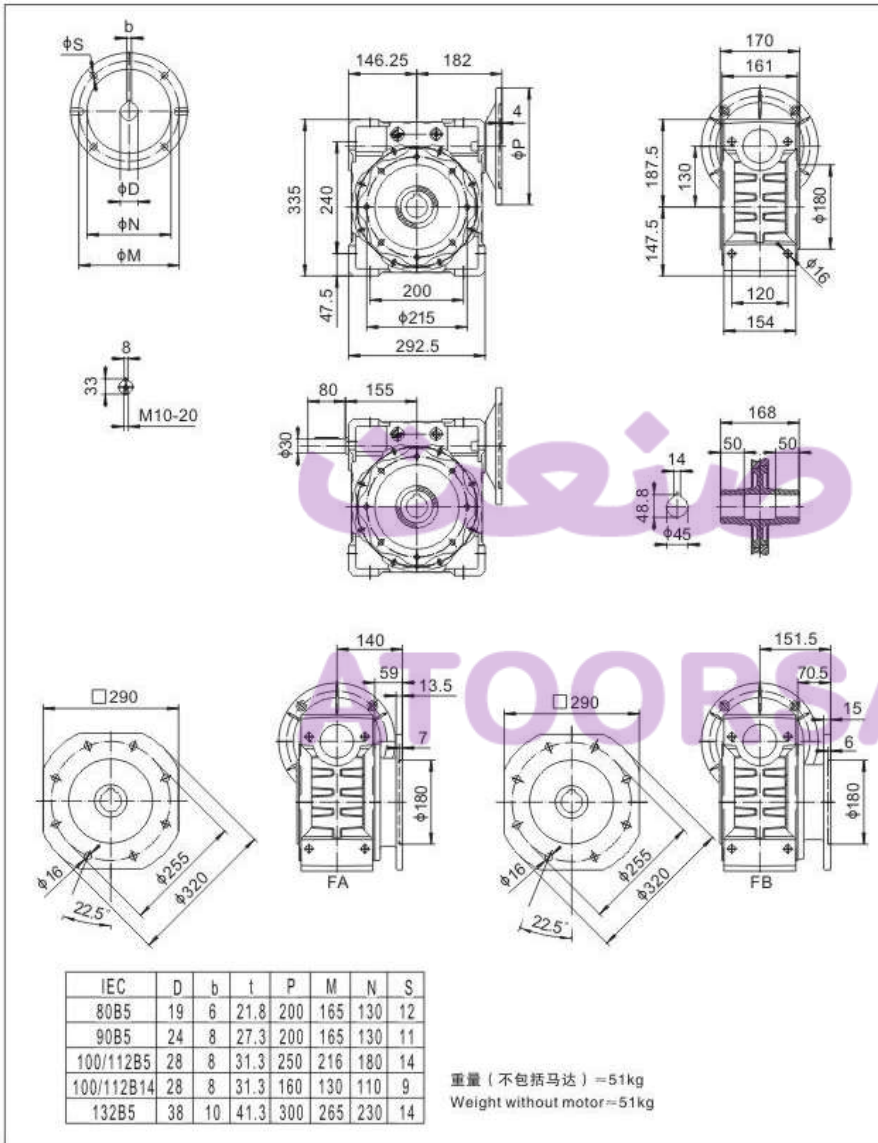

● NMRV外型尺寸图
NMRV outline dimensional drawing

NMRV150外型尺寸图 NMRV 150 external dimensions diagram

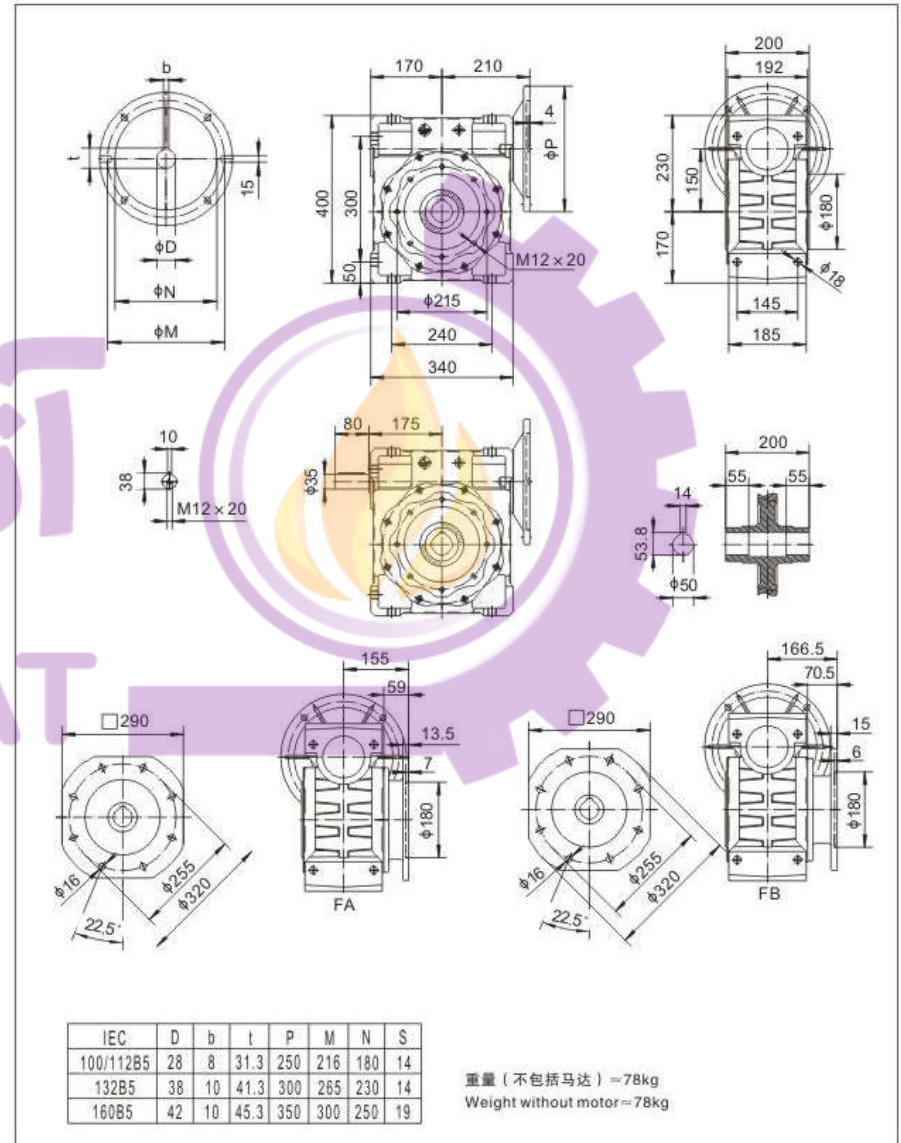

● 减速器选型表
Reducer selection table

NMRV性能参数/performance parameter								
P1n-额定输入功率 P1n-rated input power M2n-额定输出扭矩 M2n-rated output torque n2-输出转速 n2-output speed n1-输入转速 n1-input speed				i-减速器的传动比 i-transmission ratio fs-使用系数 fs-service factor Fr2-输出轴 径向载荷 Fr2-radial load on output shaft Fr1-输入轴径向载荷 Fr1-radial load on input shaft				
P1n	n2	M2n	i	Fr2	fs	减速器型号	电机型号	
KW	r/mim	Nm		N				
0.06	186.7	2.6	7.5	683	7.0	NMRV030	56B5/B14	5614
	140	3.3	10	752	5.4			
	93.3	4.7	15	861	3.9			
	70	5.9	20	948	3.1			
	56	6.8	25	1021	3.1			
	46.7	7.9	30	1085	2.5			
	35	9.7	40	1194	1.9			
	28	11	50	1286	1.5			
	23.3	12	60	1367	1.3			
	17.5	14	80	1504	0.9			
0.09	186.7	3.9	7.5	683	4.7	NMRV030	56B5/B14	5624
	140	5	10	752	3.6			
	93.3	7	15	861	2.6			
	70	8.8	20	948	2.0			
	56	10	25	1021	2.1			
	46.7	12	30	1085	1.7			

● 减速器选型表
Gear unit selection tables

NMRV性能参数/performance parameter											
P1n	n2	M2n	i	Fr2	fs	减速器型号		电机型号			
KW	r/min	Nm		N							
0.09	35	14	40	1194	1.2	NMRV030	56B5/B14	5624			
	28	17	50	1286	1.0						
	23.3	18	60	1367	0.9						
	28	19	50	2475	2.1	NMRV040	56B5	5624			
	23.3	21	60	2630	1.7						
	17.5	25	80	2895	1.3						
14	29	100	3118	1.0							
0.12	186.7	5.2	7.5	683	3.5	NMRV030	65B5/B14	6314			
	140	6.6	10	752	2.7						
	93.3	9.3	15	861	1.9						
	70	12	20	948	1.5						
	56	14	25	1021	1.6						
	46.7	16	30	1085	1.3						
	35	19	40	1194	0.9						
	28	22	50	1286	0.8						
	46.7	17	30	2087	2.7				NMRV040	63B5/B14	6314
	35	21	40	2298	1.9						
28	25	50	2475	1.6							
23.3	28	60	2630	1.3							
17.5	33	80	2895	1.0							
14	38	100	3118	0.8							
23.3	29	60	3610	2.3	NMRV050	63B5	6314				

● 减速器选型表
Gear unit selection tables

NMRV性能参数/performance parameter								
P1n	n2	M2n	i	Fr2	fs	减速器型号		电机型号
KW	r/min	Nm		N				
0.12	17.5	35	80	3973	1.9	NMRV050	63B5	6314
	14	39	100	4280	1.4			
0.18	186.7	7.7	7.5	683	2.3	NMRV030	63B5/B14	6324
	140	10	10	752	1.8			
	93.3	14	15	861	1.3			
	70	18	20	948	1.0			
	56	20	25	1021	1.0			
	46.7	24	30	1085	0.8			
	70	19	20	1824	2.1	NMRV040	63B5/B14	6324
	56	23	25	1964	1.7			
	46.7	25	30	2087	1.8			
	35	32	40	2298	1.3			
	28	37	50	2475	1.0			
	23.3	42	60	2630	0.9			
	45	28	20	2113	1.6	NMRV040	71B5/B14	7116
	36	34	25	2276	1.3			
	30	38	30	2419	1.3			
	22.5	47	40	2662	1.0			
	35	33	40	3153	2.3	NMRV050	63B5	6324
	28	39	50	3397	1.9			
23.3	43	60	3610	1.6				
17.5	52	80	3973	1.2				

● 减速器选型表
Gear unit selection tables

NMRV性能参数/performance parameter								
P1n	n2	M2n	i	Fr2	fs	减速器型号		电机型号
KW	r/min	Nm		N				
0.18	14	59	100	4280	0.9	NMRV050	63B5	6324
	18	56	50	3936	1.4			
	15	63	60	4183	1.1			
0.25	11.3	75	80	4604	0.9	NMRV050	71B5/B14	7116
	15	66	60	5467	2.1			
	11.3	79	80	6018	1.6	NMRV063	71B5/B14	7116
	9	90	100	6270	1.4			
	186.7	11	7.5	1315	3.6	NMRV040	71B5/B14	7114
	140	14	10	1447	2.8			
	93.3	20	15	1657	2.0			
	70	26	20	1824	1.5			
	56	32	25	1964	1.2			
	46.7	35	30	2087	1.3			
35	44	40	2298	0.9				
120	17	7.5	1524	2.6				
90	22	10	1677	2.0				
60	31	15	1920	1.4				
45	39	20	2113	1.1	NMRV040	71B5/B14	7126	
36	48	25	2276	0.9				
30	53	30	2419	0.9				
0.25	70	27	20	2503	2.7	NMRV050	71B5/B14	7114
	56	32	25	2696	2.2			

● 减速器选型表
Gear unit selection tables

NMRV性能参数/performance parameter								
P1n	n2	M2n	i	Fr2	fs	减速器型号		电机型号
KW	r/min	Nm		N				
0.25	46.7	36	30	2865	2.3	NMRV050	71B5/B14	7114
	35	46	40	3153	1.7			
	28	54	50	3397	1.4			
	23.3	60	60	3610	1.1			
	17.5	72	80	3973	0.9			
	45	40	20	2900	1.9	NMRV050	71B5/B14	7126
	36	48	25	3124	1.5			
	30	54	30	3320	1.7			
	22.5	67	40	3654	1.2			
	18	78	50	3936	1.0			
	15	88	60	4183	0.8	NMRV063	71B5/B14	7114
	28	55	50	4440	2.4			
	23.3	63	60	4719	2.0			
	17.5	76	80	5193	1.6			
	14	87	100	5595	1.4			
	18	81	50	5145	1.8	NMRV063	71B5/B14	7126
	15	92	60	5467	1.5			
	11.3	110	80	6018	1.2			
	9	125	100	6270	1.0			
	17.5	80	80	6130	2.4			
14	94	100	6603	1.9	NMRV075	71B5	7114	
11.3	117	80	7103	1.7	NMRV075	71B5	7126	

● 减速器选型表
Gear unit selection tables

NMRV性能参数/performance parameter									
P1n	n2	M2n	i	Fr2	fs	减速器型号		电机型号	
KW	r/min	Nm		N					
0.37	0.25	9	133	100	7180	1.4	NMRV075	71B5	7126
	186.7	16	7.5	1315	2.5	NMRV040	71B5/B14	7124	
	140	21	10	1447	1.9				
	93.3	30	15	1657	1.3				
	70	39	20	1824	1.0				
	56	47	25	1964	0.8				
	46.7	52	30	2087	0.9	NMRV050	71B5/B14	7124	
	140	21	10	1987	3.4				
	93.3	31	15	2274	2.4				
	70	39	20	2503	1.9				
	56	47	25	2696	1.5				
	46.7	54	30	2865	1.6	NMRV050	80B5/B14	8016	
	35	68	40	3153	1.1				
	28	80	50	3397	0.9				
	23.3	89	60	3610	0.8				
	120	25	7.5	2091	3.4				
	90	33	10	2302	2.6	NMRV050	80B5/B14	8016	
	60	47	15	2635	1.8				
	45	59	20	2900	1.3				
	36	72	25	3124	1.0				
30	80	30	3320	1.1					
35	70	40	4122	2.1	NMRV063	71B5/B14	7124		

● 减速器选型表
Gear unit selection tables

NMRV性能参数/performance parameter								
P1n	n2	M2n	i	Fr2	fs	减速器型号		电机型号
KW	r/min	Nm		N				
0.37	28	82	50	4440	1.6	NMRV063	71B5/B14	7124
	23.3	94	60	4719	1.4			
	17.5	113	80	5193	1.1			
	14	129	100	5595	0.9			
	45	60	20	3791	2.4	NMRV063	80B5/B14	8016
	36	73	25	4084	1.9			
	30	82	30	4339	2.1			
	22.5	102	40	4776	1.6			
	18	120	50	5145	1.2			
	15	137	60	5467	1.0			
	23.3	97	60	5569	2.1			
	17.5	119	80	6130	1.6			
	14	139	100	6603	1.3	NMRV075	71B5	7124
	18	124	50	6073	1.8	NMRV075	80B5/B14	8016
	15	141	60	6453	1.5			
	11.3	173	80	7103	1.2			
9	196	100	7380	1.0				
0.55	11.3	185	80	7859	1.7	NMRV090	80B5/B14	8016
	9	212	100	8180	1.3			
	186.7	24	7.5	1805	2.9			
140	32	10	1987	2.3				
93.3	46	15	2274	1.6				

● 减速器选型表
Gear unit selection tables

NMRV性能参数/performance parameter								
P1n	n2	M2n	i	Fr2	fs	减速器型号		电机型号
KW	r/min	Nm		N				
0.55	70	59	20	2503	1.2	NMRV050	80B5/B14	8014
	56	70	25	3696	1.0			
	46.7	80	30	2865	1.1			
	120	37	7.5	2091	2.3	NMRV050	80B5/B14	8026
	90	48	10	2302	1.7			
	60	69	15	2635	1.2			
	45	88	20	2900	0.9			
	70	60	20	3272	2.2			
	56	72	25	3524	1.8			
	46.7	82	30	3745	1.9	NMRV063	80B5/B14	8014
	35	104	40	4122	1.4			
	28	122	50	4440	1.1			
	23.3	140	60	4719	0.9			
	60	70	15	3444	2.2	NMRV063	80B5/B14	8026
	45	90	20	3791	1.6			
	36	108	25	4084	1.3			
30	123	30	4339	1.4				
22.5	152	40	4776	1.1				
35	108	40	4865	2.0				
28	128	50	5241	1.6	NMRV075	80B5/B14	8014	
23.3	144	60	5569	1.4				
17.5	177	80	6130	1.1				

● 减速器选型表
Gear unit selection tables

NMRV性能参数/performance parameter								
P1n	n2	M2n	i	Fr2	fs	减速器型号		电机型号
KW	r/min	Nm		N				
0.55	14	206	100	6603	0.9	NMRV075	80B5/B14	8014
	30	124	30	5122	2.1	NMRV075	80B5/B14	8026
	22.5	156	40	5637	1.5			
	18	184	50	6073	1.2			
	15	210	60	6453	1.0			
	17.5	189	80	6783	1.5	NMRV090	80B5/B14	8014
	14	221	100	7306	1.2			
	18	196	50	6719	2.0	NMRV090	80B5/B14	8026
	15	224	60	7140	1.6			
	11.3	275	80	7859	1.1			
	9	315	100	8180	0.9			
	17.5	201	80	8571	2.4	NMRV105	80B5	8014
	14	236	100	9232	1.9			
	11.3	294	80	9931	1.8	NMRV105	80B5	8026
	9	344	100	10320	1.4			
	17.5	201	80	8571	2.6	NMRV110	80B5	8014
	14	236	100	9232	2.0			
	11.3	294	80	9931	1.9	NMRV110	80B5	8026
9	344	100	10320	1.5				
0.75	186.7	33	7.5	1805	2.1	NMRV050	80B5/B14	8024
	140	43	10	1987	1.7			
	93.3	62	15	2274	1.2			

● 减速器选型表
Gear unit selection tables

NMRV性能参数/performance parameter								
P1n	n2	M2n	i	Fr2	fs	减速器型号		电机型号
KW	r/min	Nm		N				
0.75	70	80	20	2503	0.9	NMRV050	80B5/B14	8024
	93.3	63	15	2973	2.2	NMRV063	80B5/B14	8024
	70	82	20	3272	1.6			
	56	98	25	3524	1.3			
	46.7	112	30	3745	1.4			
	35	141	40	4122	1.0	NMRV063	80B5/B14	8024
	120	51	7.5	2734	2.9			
	90	67	10	3009	2.3	NMRV063	90B5/B14	90S6
	60	96	15	3444	1.6			
	45	123	20	3791	1.2			
	36	147	25	4084	0.9			
	30	167	30	4339	1.0	NMRV075	80B5/B14	8024
	56	101	25	4160	2.0			
	46.7	117	30	4421	2.0			
	35	147	40	4865	1.5			
	28	174	50	5241	1.2	NMRV075	90B5/B14	90S6
	23.3	196	60	5569	1.0			
	60	97	15	4065	2.4			
	45	124	20	4474	1.9			
	36	149	25	4820	1.4	NMRV075	90B5/B14	90S6
	30	170	30	5122	1.5			
	22.5	213	40	5637	1.1			

● 减速器选型表
Gear unit selection tables

NMRV性能参数/performance parameter									
P1n	n2	M2n	i	Fr2	fs	减速器型号		电机型号	
KW	r/min	Nm		N					
0.75	28	182	50	5799	1.9	NMRV90	80B5/B14	8024	
	23.3	209	60	6163	1.5				
	17.5	258	80	6783	1.1				
	14	302	100	7306	0.9				
	30	179	30	5667	2.6	NMRV090	90B5/B14	90S6	
	22.5	226	40	6238	1.8				
	18	267	50	6719	1.5				
	15	306	60	7140	1.1				
	17.5	274	80	8571	1.8	NMRV105	80B5	8024	
	14	322	100	9232	1.4				
	15	325	60	9023	1.9	NMRV105	90B5	90S6	
	11.3	401	80	9931	1.3				
	9	470	100	10320	1.0				
	17.5	274	80	8571	1.9				
	14	322	100	9232	1.5	NMRV110	80B5	8024	
	15	325	60	9023	2.1	NMRV110	90B5	90S6	
	11.3	401	80	9931	1.4				
	9	470	100	10320	1.1				
	1.1	11.3	401	80	12989	2.1	NMRV130	90B5	90S6
		9	470	100	13500	1.7			
120		75	7.5	2734	2.0	NMRV63	90B5/B14	90L6	
90	98	10	3009	1.6					

● 减速器选型表
Gear unit selection tables

NMRV性能参数/performance parameter								
P1n	n2	M2n	i	Fr2	fs	减速器型号		电机型号
KW	r/min	Nm		N				
1.1	60	140	15	3444	1.1	NMRV063	90B5/B14	90L6
	45	180	20	3791	0.8			
	186.7	50	7.5	2359	2.6	NMRV063	90B5/B14	90S4
	140	65	10	2597	2.0			
	93.3	92	15	2973	1.5			
	70	120	20	3272	1.1			
	56	144	25	3524	0.9	NMRV075	90B5/B14	90L6
	46.7	164	30	3745	1.0			
	90	98	10	3551	2.3			
	60	142	15	4065	1.7			
	45	182	20	4474	1.3	NMRV075	90B5/B14	90S4
	36	219	25	4820	1.0			
	30	249	30	5122	1.0			
	93.3	95	15	3509	2.1	NMRV090	90B5/B14	90L6
	70	122	20	3862	1.7			
	56	148	25	4160	1.3			
	46.7	171	30	4421	1.3			
	35	216	40	4865	1.0	NMRV090	90B5/B14	90L6
	36	228	25	5333	1.6			
	30	263	30	5667	1.8			
22.5	331	40	6238	1.2				
18	391	50	6719	1.0				

● 减速器选型表
Gear unit selection tables

NMRV性能参数/performance parameter								
P1n	n2	M2n	i	Fr2	fs	减速器型号		电机型号
KW	r/min	Nm		N				
1.1	15	448	60	7140	0.8	NMRV090	90B5/B14	90L6
	35	222	40	5383	1.6	NMRV090	90B5/B14	90S4
	28	266	50	5799	1.3			
	23.3	306	60	6163	1.0			
	22.5	345	40	7882	2.0	NMRV105	90B5	90L6
	18	414	50	8491	1.6			
	15	476	60	9023	1.3			
	11.3	588	80	9931	0.9			
	28	278	50	7328	2.2	NMRV105	90B5	90S4
	23.3	324	60	7787	1.7			
	17.5	402	80	8571	1.2			
	14	473	100	9232	1.0			
	22.5	345	40	7882	2.3	NMRV110	90B5	90L6
	18	414	50	8491	1.8			
	15	476	60	9023	1.4			
	11.3	588	80	9931	1.0			
	28	278	50	7328	2.4	NMRV110	90B5	90S4
	23.3	324	60	7787	1.9			
	17.5	402	80	8571	1.3			
	14	473	100	9232	1.0			
11.3	588	80	12989	1.5	NMRV130	90B5	90L6	
9	689	100	13500	1.1				

● 减速器选型表
Gear unit selection tables

NMRV性能参数/performance parameter								
P1n	n2	M2n	i	Fr2	fs	减速器型号		电机型号
KW	r/min	Nm		N				
1.1	17.5	408	80	11210	2.1	NMRV130	90B5	90S4
	14	480	100	12076	1.5			
1.5	186.7	68	7.5	2359	1.9	NMRV063	90B5/B14	90L4
	140	88	10	2597	1.5			
	93.3	126	15	2973	1.1			
	70	164	20	3272	0.8			
	120	103	7.5	3227	21	NMRV075	100B5/B14	100L6
	90	134	10	3551	1.7			
	60	193	15	4065	1.2			
	140	89	10	3065	2.2			
	93.3	129	15	3509	1.6	NMRV075	90B5/B14	90L4
	70	166	20	3862	1.3			
	56	202	25	4160	1.0			
	46.7	233	30	4421	1.0			
	90	137	10	3929	2.7	NMRV090	100B5/B14	100L6
	60	198	15	4498	2.1			
45	258	20	4951	1.5				
36	310	25	5333	1.2				
30	358	30	5667	1.3	NMRV090	90B5/B14	90L4	
70	170	20	4273	2.1				
56	207	25	4603	1.6				
46.7	239	30	4891	1.7				

● 减速器选型表
Gear unit selection tables

NMRV性能参数/performance parameter								
P1n	n2	M2n	i	Fr2	fs	减速器型号		电机型号
KW	r/min	Nm		N				
1.5	35	303	40	5383	1.2	NMRV090	90B5/B14	90L4
	28	363	50	5799	0.9			
	23.3	417	60	6163	0.8			
	45	264	20	6256	2.4	NMRV105	100B5/B14	100L6
	36	322	25	6739	2.0			
	30	363	30	7161	2.0			
	22.5	471	40	7882	1.5			
	18	565	50	8491	1.2			
	15	649	60	9023	1.0			
	35	315	40	6803	1.9			
	28	379	50	7328	1.6			
	23.3	442	60	7787	1.3	NMRV105	90B5	90L4
	17.5	548	80	8571	0.9	NMRV110	100B5/B14	100L6
	45	264	20	6256	2.7			
	36	322	25	6739	2.4			
	30	363	30	7161	2.3			
	22.5	471	40	7882	1.7			
	18	565	50	8491	1.3			
	15	649	60	9023	1.1			
	35	315	40	6803	2.2			
28	379	50	7328	1.7	NMRV110	90B5	90L4	
23.3	442	60	7787	1.4				

● 减速器选型表
Gear unit selection tables

NMRV性能参数/performance parameter									
P1n	n2	M2n	i	Fr2	fs	减速器型号		电机型号	
KW	r/min	Nm		N					
1.5	17.5	548	80	8571	0.9	NMRV110	90B5	90L4	
	22.5	471	40	10309	2.3	NMRV130	100B5/B14	100L6	
	18	565	50	11105	1.9				
	15	659	60	11801	1.4				
	11.3	802	80	12989	1.1				
	17.5	557	80	11210	1.5	NMRV130	90B5	90L4	
	14	655	100	12076	1.1	NMRV150	100B5	100L6	
	18	589	50	15182	2.7				
	15	378	60	16133	2.1				
	11.3	841	80	17757	1.5				
	9	971	100	18000	1.2				
	186.7	99	7.5	2785	1.9				NMRV075
	140	131	10	3065	1.5				
	2.2	93.3	189	15	3509	1.1	NMRV090	100B5/B14	100LA4
		186.7	100	7.5	3081	2.9			
		140	132	10	3391	2.3			
		93.3	191	15	3882	1.9			
		70	249	20	4273	1.4			
		56	304	25	4603	1.1			
		46.7	351	30	4891	1.2			
120		154	7.5	3570	2.2	NMRV090			
90		201	10	3929	1.8				

● 减速器选型表
Gear unit selection tables

NMRV性能参数/performance parameter								
P1n	n2	M2n	i	Fr2	fs	减速器型号		电机型号
KW	r/min	Nm		N				
2.2	60	291	15	4498	1.4	NMRV090	112B5/B14	112M6
	45	378	20	4951	1.0			
	70	255	20	5399	2.2	NMRV105	100B5/B14	100LA4
	56	311	25	5816	1.9			
	46.7	356	30	6181	1.8			
	35	462	40	6803	1.3			
	28	555	50	7328	1.1			
	23.3	648	60	7787	0.9			
	90	203	10	4965	3.1			
	60	294	15	5684	2.2			
	45	388	20	6256	1.6	NMRV105	112B5/B14	112M6
	36	473	25	6739	1.4			
	30	532	30	7161	1.4	NMRV110	100B5/B14	100LA4
	70	255	20	5399	2.5			
	56	311	25	5816	2.2			
	6.7	356	30	6181	2.0			
	35	462	40	3803	1.5			
	28	555	50	7328	1.2			
	23.3	648	60	7787	1.0			
	90	203	10	4965	3.5			
60	394	15	5684	2.6	NMRV110	112B5/B14	112M6	
45	388	20	6256	1.9				

● 减速器选型表
Gear unit selection tables

NMRV性能参数/performance parameter								
P1n	n2	M2n	i	Fr2	fs	减速器型号		电机型号
KW	r/min	Nm		N				
2.2	36	473	25	6739	1.6	NMRV110	112B5/B14	112M6
	30	532	30	7161	1.6			
	35	468	40	8897	2.2	NMRV130	100B5/B14	100LA4
	28	563	50	9584	1.7			
	23.3	657	60	10185	1.4			
	17.5	816	80	11210	1.0			
	36	473	25	8814	2.2			
	30	539	30	9366	2.2			
	22.5	691	40	10309	1.6	NMRV130	112B5	112M6
	18	829	50	11105	1.3			
	15	966	60	11801	1.0			
	28	570	50	13103	2.5			
	23.3	657	60	13924	1.9	NMRV150	100B5	100LA4
	17.5	816	80	15325	1.4			
	14	960	100	16508	1.0			
	18	864	50	15182	1.9			
	15	995	60	16133	1.4	NMRV150	112B5	112M6
	11.3	1233	80	17757	1.1			
	9	1425	100	18000	0.8			
	3.0	186.7	135	7.5	2785	1.4	NMRV075	100B5/B14
140		178	10	3065	1.1			
93.3		258	15	3509	0.8			

● 减速器选型表
Gear unit selection tables

NMRV性能参数/performance parameter								
P1n	n2	M2n	i	Fr2	fs	减速器型号		电机型号
KW	r/min	Nm		N				
3.0	186.7	137	7.5	3081	2.1	NMRV90	100B5/B14	100LB4
	140	180	10	3391	1.7			
	93.3	361	1.5	3882	1.4			
	70	340	20	4273	1.0			
	56	414	25	4603	0.8			
	46.7	479	30	4891	0.9			
	93.3	264	15	4905	2.2	NMRV105	100B5/B14	100LB4
	70	348	20	5399	1.6			
	56	425	25	5816	1.4			
	46.7	485	30	6181	1.3			
	35	630	40	6803	1.0			
	28	757	60	7328	0.8			
	120	210	7.5	4511	2.7	NMRV105	132B5	132S6
	90	277	10	4965	2.2			
	60	401	15	5684	1.6			
	45	528	20	6256	1.2			
	93.3	264	15	4905	2.5			
	70	348	20	5399	1.9			
	56	425	25	5816	1.6	NMRV110	100B5/B14	100LB4
	46.7	485	30	6181	1.5			
	35	630	40	6803	1.1			
	28	757	50	7328	0.9			

● 减速器选型表
Gear unit selection tables

NMRV性能参数/performance parameter											
P1n	n2	M2n	i	Fr2	fs	减速器型号		电机型号			
KW	r/min	Nm		N							
3.0	120	210	7.5	4511	3.1	NMRV110	132B5	132S6			
	90	277	10	4965	2.6						
	60	401	15	5684	1.9						
	45	528	20	6256	1.4						
	56	430	25	7607	2.2						
	46.7	491	30	8084	2.1						
	35	638	40	8897	1.6	NMRV130	100B5/B14	100LB4			
	28	767	50	9584	1.3						
	23.3	869	60	10185	1.0						
	17.5	1113	80	11210	0.8						
	90	277	10	6494	3.5						
	60	406	15	7434	2.6						
	45	528	20	8182	2.0	NMRV130	132B5	132S6			
	36	645	25	8814	1.6						
	30	735	30	9366	1.6						
	22.5	942	40	10309	1.2						
	28	778	50	13103	1.8						
	23.3	896	60	13924	1.4						
	17.5	1113	80	15325	1.0	NMRV150	100B5	100LB4			
	14	1310	100	16508	0.8						
	45	541	20	11186	2.8						
	36	669	25	12050	2.1				NMRV150	132B5	132S6

● 减速器选型表
Gear unit selection tables

NMRV性能参数/performance parameter								
P1n	n2	M2n	i	Fr2	fs	减速器型号		电机型号
KW	r/min	Nm		N				
3.0	30	783	30	12805	1.8	NMRV150	132B5	132S6
	22.5	968	40	14094	1.9			
	18	1178	50	15182	1.4			
	15	1357	60	16133	1.1			
	11.3	1682	80	17757	0.8			
4.0	186.7	180	7.5	2785	1.0	NMRV075	112B5/B14	112M4
	140	237	10	3065	0.8	NMRV090	112B5/B14	112M4
	186.7	182	7.5	3081	1.6			
	140	240	10	3391	1.3			
	93.3	348	15	3882	1.0			
	70	453	20	4273	0.8			
	140	240	10	4285	2.2	NMRV105	112B5/B14	112M4
	93.3	352	15	4905	1.6			
	70	464	20	5399	1.2			
	56	566	25	5816	1.0			
	46.7	647	30	6181	1.0			
	120	280	7.5	4511	2.0	NMRV105	132B5	132MA6
	90	369	10	4965	1.7			
	60	535	15	5684	1.2			
	140	240	10	4285	2.5	NMRV110	112B5/B14	112M4
93.3	352	15	4905	1.9				
70	464	20	5399	1.4				

● 减速器选型表
Gear unit selection tables

NMRV性能参数/performance parameter								
P1n	n2	M2n	i	Fr2	fs	减速器型号		电机型号
KW	r/min	Nm		N				
4.0	56	566	25	5816	1.2	NMRV110	112B5/B14	112M4
	46.7	647	30	6181	1.1			
	120	280	7.5	4511	2.3			
	90	369	10	4965	1.9	NMRV110	132B5	132MA6
	60	535	15	5684	1.4			
	56	573	25	7607	1.6			
	46.7	655	30	8084	1.6	NMRV130	112B5/B14	112M4
	35	851	40	4497	1.2			
	28	1023	50	9584	1.0			
	23.3	1195	60	10185	0.8			
	120	283	7.5	5901	3.1			
	90	369	10	6494	2.6	NMRV130	132B5	132MA6
	60	541	15	7434	2.0			
	45	705	20	8182	1.5			
	36	860	25	8814	1.2			
28	1037	50	13103	1.4				
23.3	1195	60	13924	1.1	NMRV150	112B5	112M4	
17.5	1484	80	15325	0.8				
45	722	20	11186	2.1				
36	892	25	12050	1.5	NMRV150	132B5	132MA6	
30	1045	30	12805	1.3				
22.5	1291	40	14094	1.4				

● 减速器选型表
Gear unit selection tables

NMRV性能参数/performance parameter								
P1n	n2	M2n	i	Fr2	fs	减速器型号		电机型号
KW	r/min	Nm		N				
4.0	18	1571	50	15182	1.0	NMRV150	132B5	132MA6
	15	1809	60	16133	0.8			
5.5	186.7	250	7.5	3893	1.9	NMRV105	132B5	132S4
	140	330	10	4285	1.6			
	93.3	484	15	4905	1.2			
	70	638	20	5399	0.9			
	186.7	250	7.5	3893	2.2	NMRV110	132B5	132S4
	140	330	10	4285	1.8			
	93.3	484	15	4905	1.4			
	70	638	20	5399	1.0			
	120	390	7.5	4511	1.7	NMRV110	132B5	132MB6
	90	514	10	4965	1.4			
	60	753	15	5684	1.0			
	140	334	10	5605	2.5			
	93.3	490	15	6416	1.9	NMRV130	132B5	132S4
	70	638	20	7062	1.4			
	56	788	25	7607	1.2			
	46.7	900	30	8084	1.2			
35	1171	40	8897	0.9	NMRV130	132B5	132MB6	
120	394	7.5	5901	2.2				
90	514	10	6494	1.9				
60	744	15	7434	1.4				

● 减速器选型表
Gear unit selection tables

NMRV性能参数/performance parameter											
P1n	n2	M2n	i	Fr2	fs	减速器型号		电机型号			
KW	r/min	Nm		N							
5.5	45	993	20	8182	1.0	NMRV130	132B5	132MB6			
	36	1212	25	8814	0.9						
	30	1384	30	9366	0.8						
5.5	70	645	20	9654	2.0	NMRV150	132B5	132S4			
	56	788	25	10400	1.5						
	46.7	934	30	11051	1.3						
	35	1171	40	12463	1.3						
	28	1426	50	13103	1.0						
	23.3	1643	60	13924	0.8						
	45	993	20	11186	1.5				NMRV150	132B5	132MB6
	36	1226	25	12050	1.1						
	30	1436	30	12805	1.0						
	22.5	1775	40	14094	1.0						
7.5	186.7	341	7.5	3893	1.4	NMRV105	132B5	132M4			
	140	450	10	4285	1.2						
	93.3	660	15	4905	0.9						
	186.7	341	7.5	3893	1.6	NMRV110	132B5	132M4			
	140	450	10	4285	1.3						
	93.3	660	15	4905	1.0						
	186.7	345	7.5	5092	2.2						
	140	455	10	5605	1.8	NMRV130	132B5	132M4			
	93.3	668	15	6416	1.4						

● 减速器选型表
Gear unit selection tables

NMRV性能参数/performance parameter								
P1n	n2	M2n	i	Fr2	fs	减速器型号		电机型号
KW	r/min	Nm		N				
7.5	70	870	20	7062	1.0	NMRV130	132B5	132M4
	56	1074	25	7607	0.9			
	46.7	1228	30	8084	0.8			
	70	880	20	9654	1.5	NMRV150	132B5	132M4
	56	1074	25	10400	1.1			
	46.7	1274	30	11051	0.9			
	35	1596	40	12163	1.0			
	120	537	7.5	8067	2.6			
	90	709	10	8878	2.1	NMRV150	160B5	160M6
	60	1039	15	10163	1.4			
	45	1354	20	11186	1.1			
	36	1672	25	12050	0.8			
11	186.7	424	7.5	3893	1.3	NMRV110	132B5	132M4
	140	559	10	4285	1.1			
	93.3	819	15	4905	0.8			
	186.7	429	7.5	5092	1.8	NMRV130	132B5	132M4
	140	559	10	5605	1.5			
	93.3	819	15	6416	1.1			
	70	1092	20	7062	0.8			
	186.7	512	7.5	6962	2.3			
	140	675	10	7663	1.8	NMRV150	132B5	132M4
	93.3	990	15	8771	1.3			

● 减速器选型表
Gear unit selection tables

NRV性能参数/performance parameter								
M2n	n1	i	P1n	n2	Fr2	Fr1	减速器型号	
Nm	r/min		KW	r/min	N	N		
18	1400	7.5	0.4	186.7	683	150	NRV030	
18	1400	10	0.3	140	752	169		
18	1400	15	0.2	93.3	861	169		
18	1400	20	0.2	70	948	190		
21	1400	25	0.2	56	1021	210		
20	1400	30	0.2	46.7	1085	210		
18	1400	40	0.1	35	1194	210		
17	1400	50	0.1	28	1286	210		
16	1400	60	0.1	23.3	1367	210		
13	1400	80	0.1	17.5	1504	210		
40	1400	7.5	0.9	186.7	1315	294		NRV040
40	1400	10	0.7	140	1447	331		
40	1400	15	0.5	93.3	1657	331		
39	1400	20	0.4	70	1824	350		
38	1400	25	0.3	56	1964	350		
45	1400	30	0.3	46.7	2087	350		
41	1400	40	0.2	35	2298	350		
39	1400	50	0.2	28	2475	350		
36	1400	60	0.2	23.3	2630	350		
33	1400	80	0.1	17.5	3895	350		
29	1400	100	0.1	14	3118	350	NRV050	
71	1400	7.5	1.6	186.7	1805	401		

● 减速器选型表
Gear unit selection tables

NRV性能参数/performance parameter							
M2n	n1	i	P1n	n2	Fr2	Fr1	减速器型号
Nm	r/min		KW	r/min	N	N	
72	1400	10	1.2	140	1987	490	NRV050
74	1400	15	0.9	93.3	2274	490	
73	1400	20	0.7	70	2503	490	
70	1400	25	0.5	56	2696	490	
84	1400	30	0.6	46.7	2865	490	
76	1400	40	0.4	35	3153	490	
73	1400	50	0.3	28	3397	490	
68	1400	60	0.3	23.3	3610	490	
65	1400	80	0.2	17.5	3973	490	
55	1400	100	0.2	14	4280	490	
128	1400	7.5	2.8	186.7	2359	500	
130	1400	10	2.2	140	2597	571	
140	1400	15	1.7	93.3	2973	615	
135	1400	20	1.2	70	3272	667	
130	1400	25	1	56	3524	700	
160	1400	30	1.1	46.7	3745	700	
145	1400	40	0.8	35	4122	700	
135	1400	50	0.6	28	4440	700	
130	1400	60	0.5	23.3	4719	700	
122	1400	80	0.4	17.5	5193	700	
118	1400	100	0.3	14	5595	700	
185	1400	7.5	4.1	186.7	2785	700	NRV075

● 减速器选型表
Gear unit selection tables

NRV性能参数/performance parameter							
M2n	n1	i	P1n	n2	Fr2	Fr1	减速器型号
Nm	r/min		KW	r/min	N	N	
195	1400	10	3.3	140	3065	830	NRV075
200	1400	15	2.3	93.3	3509	851	
210	1400	20	1.9	70	3862	980	
200	1400	25	1.5	56	4160	980	
230	1400	30	1.5	46.7	4421	980	
220	1400	40	1.1	35	4865	980	
210	1400	50	0.9	28	5241	980	
200	1400	60	0.8	23.3	5569	980	
190	1400	80	0.6	17.5	6130	980	
180	1400	100	0.5	14	6603	980	
290	1400	7.5	6.4	186.7	3081	1082	
310	1400	10	5.2	140	3391	1257	
360	1400	15	4.1	93.3	3882	1270	
355	1400	20	3.1	70	4273	1270	
340	1400	25	2.5	56	4603	1270	
410	1400	30	2.6	46.7	4891	1270	
360	1400	40	1.8	35	5383	1270	
340	1400	50	1.4	28	5799	1270	
320	1400	60	1.1	23.3	6163	1270	
285	1400	80	0.8	17.5	6783	1270	
370	1400	100	0.7	14	7306	1270	
480	1400	7.5	10.5	186.7	3893	1200	NRV105

● 减速器选型表
Gear unit selection tables

NRV性能参数/performance parameter							
M2n	n1	i	P1n	n2	Fr2	Fr1	减速器型号
Nm	r/min		KW	r/min	N	N	
520	1400	10	8.7	140	4285	1463	NRV105
570	1400	15	6.5	93.3	4905	1604	
560	1400	20	4.8	70	5399	1700	
590	1400	25	4.2	56	5816	1700	
630	1400	30	3.9	46.7	6181	1700	
610	1400	40	2.9	35	6803	1700	
600	1400	50	2.4	28	7328	1700	
560	1400	60	1.9	23.3	7787	1700	
490	1400	80	1.3	17.5	8571	1700	
460	1400	100	1.1	14	9232	1700	
522	1400	7.5	12.1	186.7	3893	1200	NRV110
598	1400	10	7.5	140	4285	1463	
656	1400	15	10	93.3	4905	1604	
644	1400	20	5.6	70	5399	1700	
679	1400	25	4.8	56	5816	1700	
725	1400	30	4.5	46.7	6181	1700	
702	1400	40	3.3	35	6803	1700	
660	1400	50	2.6	28	7328	1700	
616	1400	60	2.1	23.3	7787	1700	
515	1400	80	1.4	17.5	8571	1700	
483	1400	100	1.1	14	9232	1700	NRV130
750	1400	7.5	16.3	186.7	5092	1500	

● 减速器选型表
Gear unit selection tables

NRV性能参数/performance parameter							
M2n	n1	i	P1n	n2	Fr2	Fr1	减速器型号
Nm	r/min		KW	r/min	N	N	
820	1400	10	13.5	140	5605	1845	NRV130
920	1400	150	10.3	93.3	6416	2070	
910	1400	20	7.8	70	7062	2100	
930	1400	25	6.5	56	7607	2100	
1040	1400	30	6.4	46.7	8084	2100	
1050	1400	40	4.9	35	8897	2100	
980	1400	50	3.8	28	9584	2100	
900	1400	60	3	23.3	10185	2100	
940	1400	80	2.3	17.5	11210	2100	
740	1400	100	1.7	14	12076	2100	
1200	1400	7.5	25.8	186.7	6962	1950	NRV150
1240	1400	10	20.2	140	7663	2267	
1250	1400	15	13.9	93.3	8771	2285	
1300	1400	20	11.1	70	9654	2674	
1200	1400	25	8.4	56	10400	2800	
1200	1400	30	7.1	46.7	11051	2800	
1550	1400	40	7.3	35	12163	2800	
1400	1400	50	5.4	28	13103	2800	
1260	1400	60	4.2	23.3	13924	2800	
1150	1400	80	3.1	17.5	15325	2800	
1000	1400	100	2.3	14	16508	2800	NRV030
20	900	7.5	0.3	120	792	175	

● 减速器选型表
Gear unit selection tables

NRV性能参数/performance parameter							
M2n	n1	i	P1n	n2	Fr2	Fr1	减速器型号
Nm	r/min		KW	r/min	N	N	
20	900	10	0.24	90	870	197	NRV030
20	900	15	0.17	60	997	197	
20	900	20	0.13	45	1098	210	
23	900	25	0.14	36	1183	210	
21	900	30	0.11	30	1257	210	
20	900	40	0.09	22.5	1383	210	
18	900	50	0.07	18	1490	210	
17	900	60	0.06	15	1583	210	
15	900	80	0.04	11.3	1743	210	
44	900	7.5	0.66	120	1524	319	
44	900	10	0.51	90	1677	350	
45	900	15	0.36	60	1920	350	
44	900	20	0.28	45	2113	350	
43	900	25	0.23	36	2276	350	
49	900	30	0.23	30	2419	350	
45	900	40	0.17	22.5	2662	350	
42	900	50	0.14	18	2868	350	
39	900	60	0.11	15	3047	350	
35	900	80	0.09	11.3	3354	350	
32	900	100	0.07	9	3490	350	
84	900	7.5	1.2	120	2091	448	
84	900	10	0.95	90	2302	490	

● 减速器选型表
Gear unit selection tables

NRV性能参数/performance parameter							
M2n	n1	i	P1n	n2	Fr2	Fr1	减速器型号
Nm	r/min		KW	r/min	N	N	
84	900	15	0.67	60	2635	490	NRV050
77	900	20	0.48	45	2900	490	
75	900	25	0.39	36	3124	490	
90	900	30	0.42	30	3320	490	
82	900	40	0.31	22.5	3654	490	
77	900	50	0.25	18	3936	490	
72	900	60	0.21	15	4183	490	
68	900	80	0.16	11.3	4604	490	
56	900	100	0.12	9	4804	490	
151	900	7.5	2.2	120	4840	580	
153	900	10	1.7	90	2734	661	
155	900	15	1.2	60	3009	670	
148	900	20	0.91	45	3444	700	
137	900	25	0.7	36	4084	700	
175	900	30	0.79	30	4339	700	
160	900	40	0.58	22.5	4776	700	
145	900	50	0.45	18	5145	700	
138	900	60	0.37	15	5467	700	
128	900	80	0.29	11.3	6018	700	
124	900	100	0.25	9	6270	700	
215	900	7.5	3.1	120	3227	810	
230	900	10	2.6	90	3551	975	

● 减速器选型表
Gear unit selection tables

NRV性能参数/performance parameter							
M2n	n1	i	P1n	n2	Fr2	Fr1	减速器型号
Nm	r/min		KW	r/min	N	N	
235	900	15	1.8	60	4065	980	NRV075
235	900	20	1.4	45	4474	980	
215	900	25	1.1	36	4820	980	
260	900	30	1.2	30	5122	980	
240	900	40	0.84	22.5	5637	980	
220	900	50	0.66	18	6073	980	
210	900	60	0.55	15	6453	980	
200	900	80	0.43	11.3	7103	980	
190	900	100	0.36	9	7380	980	
340	900	7.5	4.9	120	3570	1040	
370	900	10	4.1	90	3929	1270	
420	900	15	3.2	60	4498	1270	
390	900	20	2.3	45	4951	1270	
370	900	25	1.8	36	5333	1270	
460	900	30	1.9	30	5667	1270	
410	900	40	1.4	22.5	6238	1270	
390	900	50	1.1	18	6719	1270	
350	900	60	0.86	15	7140	1270	
315	900	80	0.63	11.3	7859	1270	
280	900	100	0.49	9	8180	1270	NRV105
565	900	7.5	8.1	120	4511	1390	
620	900	10	6.7	90	4965	1700	

● 减速器选型表
Gear unit selection tables

NRV性能参数/performance parameter							
M2n	n1	i	P1n	n2	Fr2	Fr1	减速器型号
Nm	r/min		KW	r/min	N	N	
660	900	15	4.9	60	5684	1700	NRV105
630	900	20	3.6	45	6256	1700	
660	900	25	3.1	36	6739	1700	
730	900	30	3	30	7161	1700	
690	900	40	2.2	22.5	7882	1700	
680	900	50	1.8	18	8491	1700	
620	900	60	1.4	15	9023	1700	
540	900	80	1	11.3	9931	1700	
490	900	100	0.78	9	10320	1700	
650	900	7.5	9.3	120	4511	13900	
713	900	10	7.7	90	4965	1700	
759	900	15	5.7	60	5684	1700	
725	900	20	4.1	45	6256	1700	
759	900	25	3.5	36	6739	1700	
840	900	30	3.5	30	7161	1700	
794	900	40	2.5	22.5	7882	1700	
748	900	50	2	18	8491	1700	
682	900	60	1.6	15	9023	1700	
567	900	80	1.1	11.3	9931	1700	
515	900	100	0.82	9	10320	1700	NRV130
880	900	7.5	12.4	120	5901	1740	
960	900	10	10.4	90	6494	2100	

● 减速器选型表
Gear unit selection tables

NRV性能参数/performance parameter							
M2n	n1	i	P1n	n2	Fr2	Fr1	减速器型号
Nm	r/min		KW	r/min	N	N	
1060	900	15	7.8	60	7434	2100	NRV130
1040	900	20	5.9	45	8182	2100	
1050	900	25	4.9	36	8814	2100	
1170	900	30	4.8	30	9366	2100	
1100	900	40	3.5	22.5	10309	2100	
1050	900	50	2.8	18	11105	2100	
940	900	60	2.1	15	11801	2100	
860	900	80	1.6	11.3	12989	2100	
780	900	100	1.2	9	13500	2100	
1400	900	7.5	19.5	120	8067	2270	
1480	900	10	15.7	90	8878	2700	
1450	900	15	10.5	60	10163	2645	
1500	900	20	8.4	45	11186	2800	
1380	900	25	6.3	36	12050	2800	
1400	900	30	5.4	20	12805	2800	
1800	900	40	5.7	22.5	14094	2800	
1600	900	50	4.1	18	15182	2800	
1440	900	60	3.2	15	16133	2800	
1300	900	80	2.4	11.3	17757	2800	
1150	900	100	1.8	9	18000	2800	
24	500	7.5	0.21	66.7	963	210	NRV030
24	500	10	0.16	50	1060	210	

● 减速器选型表
Gear unit selection tables

NRV性能参数/performance parameter							
M2n	n1	i	P1n	n2	Fr2	Fr1	减速器型号
Nm	r/min		KW	r/min	N	N	
24	500	15	0.12	33.3	1213	210	NRV030
23	500	20	0.09	25	1336	210	
29	500	25	0.1	20	1439	210	
26	500	30	0.08	16.7	1529	210	
23	500	40	0.06	12.5	1683	210	
21	500	50	0.05	10	1813	210	
19	500	60	0.04	8.3	1830	210	
17	500	80	0.03	6.3	1830	210	
54	500	7.5	0.45	66.7	1853	350	
54	500	10	0.35	50	2040	350	
55	500	15	0.26	33.3	2335	350	
52	500	20	0.19	25	2570	350	
19	500	25	0.15	20	2769	350	NRV040
58	500	30	0.16	16.7	2942	350	
53	500	40	0.12	12.5	3238	350	
49	500	50	0.1	10	3488	350	
46	500	60	0.08	8.3	3490	350	
40	500	80	0.06	6.3	3490	350	
36	500	100	0.05	5	3490	350	
103	500	7.5	0.87	66.7	2544	490	NRV050
103	500	10	0.67	50	2800	490	
103	500	15	0.47	33.3	3205	490	

● 减速器选型表
Gear unit selection tables

NRV性能参数/performance parameter							
M2n	n1	i	P1n	n2	Fr2	Fr1	减速器型号
Nm	r/min		KW	r/min	N	N	
93	500	20	0.33	25	3528	490	NRV050
91	500	25	0.27	20	3800	490	
108	500	30	0.3	16.7	4038	490	
98	500	40	0.22	12.5	4445	490	
91	500	50	0.17	10	4788	490	
83	500	60	0.14	8.3	4840	490	
75	500	80	0.11	6.3	4840	490	
65	500	100	0.09	5	4840	490	
184	500	7.5	1.5	66.7	3325	700	
185	500	10	1.2	50	3660	700	
187	500	15	0.85	33.3	4190	700	
178	500	20	0.63	25	4611	700	
164	500	25	0.48	20	4967	700	
200	500	30	0.53	16.7	5279	700	
185	500	40	0.4	12.5	5810	700	
173	500	50	0.32	10	6259	700	
160	500	60	0.26	8.3	6270	700	
137	500	80	0.19	6.3	6270	700	
128	500	100	0.16	5	6270	700	
260	500	7.5	2.2	66.7	3925	980	
270	500	10	1.7	50	4320	980	
280	500	15	1.3	33.3	4945	980	

● 减速器选型表
Gear unit selection tables

NRV性能参数/performance parameter							
M2n	n1	i	P1n	n2	Fr2	Fr1	减速器型号
Nm	r/min		KW	r/min	N	N	
285	500	20	0.99	25	5443	980	NRV075
255	500	25	0.74	20	5863	980	
300	500	30	0.77	16.7	6231	980	
280	500	40	0.58	12.5	6858	980	
250	500	50	0.44	10	7380	980	
240	500	60	0.38	8.3	7380	980	
215	500	80	0.28	6.3	7380	980	
210	500	100	0.24	5	7380	980	
410	500	7.5	3.3	66.7	4343	1270	
435	500	10	2.7	50	4780	1270	
490	500	15	2.1	33.3	5472	1270	
470	500	20	1.6	25	6022	1270	
440	500	25	1.2	20	6487	1270	
550	500	30	1.4	16.7	6894	1270	
480	500	40	0.94	12.5	7588	1270	
450	500	50	0.75	10	8174	1270	
400	500	60	0.58	8.3	8180	1270	
365	500	80	0.45	6.3	8180	1270	
330	500	100	0.35	5	8180	1270	
690	500	7.5	5.6	66.7	5488	1700	
740	500	10	4.6	50	6040	1700	
790	500	15	3.4	33.3	6914	1700	

● 减速器选型表
Gear unit selection tables

NRV性能参数/performance parameter							
M2n	n1	i	P1n	n2	Fr2	Fr1	减速器型号
Nm	r/min		KW	r/min	N	N	
750	500	20	2.5	25	7610	1700	NRV105
790	500	25	2.1	20	8198	1700	
870	500	30	2.1	16.7	8711	1700	
810	500	40	1.5	12.5	9588	1700	
800	500	50	1.3	10	10320	1700	
710	500	60	0.96	8.3	10320	1700	
630	500	80	0.72	6.3	10320	1700	
570	500	100	0.55	5	10320	1700	
794	500	7.5	6.4	66.7	5488	1700	
851	500	10	5.2	50	6040	1700	
909	500	15	3.9	33.3	6914	1700	
863	500	20	2.8	25	7610	1700	
909	500	25	2.4	20	8198	1700	
1000	500	30	2.4	16.7	8711	1700	
932	500	40	1.7	12.5	9588	1700	
880	500	50	1.4	10	10320	1700	
781	500	60	1.1	8.3	10320	1700	
662	500	80	0.75	6.3	10320	1700	
599	500	100	0.58	5	10320	1700	
1080	500	7.5	8.7	66.7	7178	2100	
1160	500	10	7.1	50	7900	2100	
1300	500	15	5.5	33.3	9043	2100	

● 减速器选型表
Gear unit selection tables

NRV性能参数/performance parameter							
M2n	n1	i	P1n	n2	Fr2	Fr1	减速器型号
Nm	r/min		KW	r/min	N	N	
1230	500	20	4	25	9953	2100	NRV130
1200	500	25	3.2	20	10722	2100	
1400	500	30	3.4	16.7	11394	2100	
1300	500	40	2.4	12.5	12540	2100	
1220	500	50	1.9	10	13500	2100	
1070	500	60	1.5	8.3	13500	2100	
970	500	80	1.1	6.3	13500	2100	
860	500	100	0.83	5	13500	2100	
1700	500	7.5	13.5	66.7	9812	2800	
1780	500	10	10.7	50	10800	2800	
1730	500	15	7.2	33.3	12363	2800	
1820	500	20	5.9	25	13607	2800	
1630	500	25	4.3	20	14658	2800	
1670	500	30	3.8	16.7	15576	2800	
2120	500	40	3.9	12.5	17144	2800	
1870	500	50	2.9	10	18000	2800	
1680	500	60	2.3	8.3	18000	2800	
1530	500	80	1.7	6.3	18000	2800	
1350	500	100	1.3	5	18000	2800	

RV系列组合型二级蜗杆减速器型号表示法 (一) Model designation for double stage worm gear reducer



示例 Example

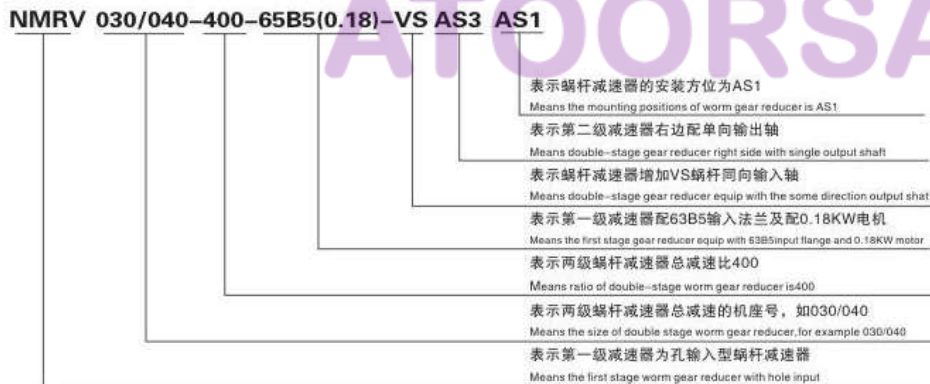

RV系列组合型二级蜗杆减速器型号表示法 (二) Model designation for double stage worm gear reducer



示例 Example

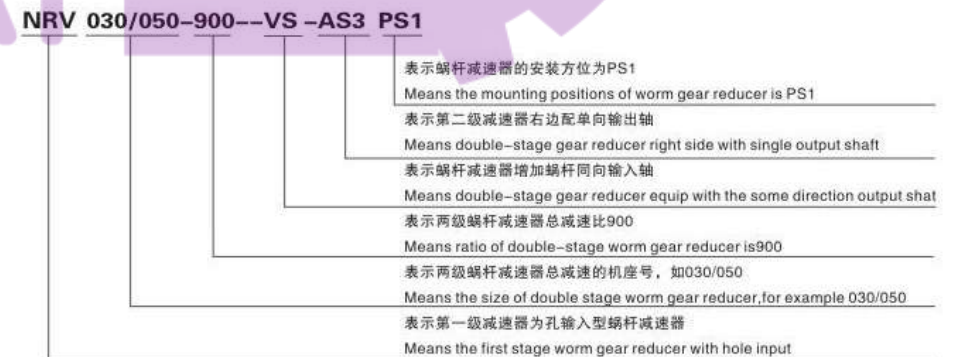

组合型二级蜗杆减速器外形尺寸图
Diagram for double-stage worm reducer combination

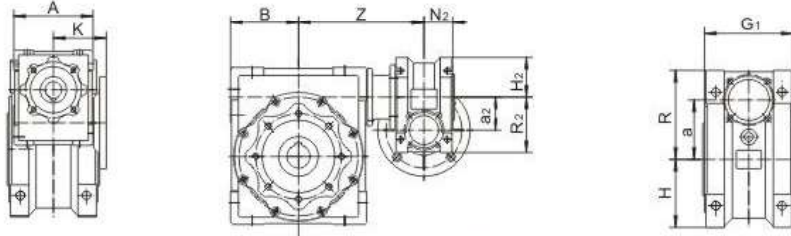

NMRV	030/040	030/050	030/063	040/040	040/050	040/063	040/075	040/090	050/050	050/063	050/075
A	80	80	80	100	100	100	100	100	120	120	120
K	55	55	55	70	70	70	70	70	80	80	80
B	50	60	72	50	60	72	86	103	60	72	86
Z	116	128	146	126	139	152	167	183	145.5	159	174
N ₂	29	29	29	37	37	37	37	37	43.5	43.5	43.5
a ₂	300	30	30	40	40	40	40	40	50	50	50
H ₂	40	40	40	50	50	50	50	60	60	60	60
R ₂	57	57	57	71.5	71.5	71.5	71.5	71.5	84	84	84
G ₁	74	87	106	74	87	106	114	134	87	106	114
a	40	50	63	40	50	63	75	90	50	63	75
R	71.5	84	102	71.5	84	102	119	135	84	102	119
H	50	60	72	50	60	72	86	103	60	72	86
NMRV	050/090	063/075	063/090	063/110	063/130	075/090	075/110	075/130	090/110	090/130	110/130
A	120	144.5	144	144	144	172	172	172	206	206	252.5
K	80	95.75	95	95	95	112.5	112.5	112.5	129.5	129.5	162
B	103	86	103	126	146	103	126	146	126	146	146
Z	190	183.5	199.5	231	251	211	235	255	245	265	259
N ₂	13.5	53	53	53	53	57	57	57	67	67	74
a ₂	50	63	63	63	63	75	75	75	90	90	110
H ₂	60	72	72	72	72	86	86	86	103	103	127.5
R ₂	84	102	102	102	102	119	119	119	135	135	167.5
G ₁	134	114	134	148	132	134	148	162	148	162	162
a	90	85	90	110	130	90	110	130	110	130	130
R	135	119	135	167.5	187.5	135	167.5	187.5	167.5	187.5	187.5
H	103	86	103	127.5	147.5	103	127.5	147.5	127.5	147.5	147.5

NMRV联体型 性能参数
Performance parameter

P1n	n2	M2n	i	Fr2	fs	减速器型号	电机型号
KW	r/min	Nm		N			
0.06	4.7	55	300	3490	1.3	NMRV030/040	5614
	3.5	67	400	3490	0.9		
	2.8	88	500	3490	0.6		
	2.3	95	600	3490	0.7		
	1.9	103	750	3490	0.6		
	1.6	118	900	3490	0.5		
	1.2	143	1200	3490	0.4		
	0.8	184	1800	3490	0.3		
	0.6	217	2400	3490	0.2		
	0.4	247	3200	3490	0.2		
	0.4	278	4000	3490	0.1		
	0.3	327	5000	3490	0.1		
	1.6	118	900	4840	1.0	NMRV030/050	5614
	1.2	143	1200	4840	0.7		
	0.9	166	1500	4840	0.7		
	0.8	184	1800	4840	0.7		
	0.6	227	2400	4840	0.5		
	0.5	256	3000	4840	0.4		
0.4	278	4000	4840	0.3			
0.3	316	4800	4840	0.3			
0.9	173	1500	6270	1.1	NMRV030/063	5614	
0.8	191	1800	6270	0.9			
0.6	227	2400	6270	0.8			
0.5	256	3000	6270	0.7			

NMRV联体型 性能参数
Performance parameter

P1n KW	n2 r/min	M2n Nm	i	Fr2	fs	减速器型号	电机型号
				N			
0.06	0.4	295	4000	6270	0.6	NMRV030/063	5614
	0.3	327	5000	6270	0.4		
	0.6	267	2400	7380	1.1	NMRV040/075	5614
	0.5	305	3000	7380	0.8		
	0.4	362	4000	7380	0.7		
	0.3	409	5000	7380	0.5		
	0.5	329	3000	8180	1.4	NMRV040/090	5614
	0.4	392	4000	8180	1.3		
	0.3	430	5000	8180	1		
0.3	430	5000	8180	1			
0.09	4.7	82	300	3490	0.8	NMRV030/040	5624
	3.5	103	400	4840	1.2	NMRV030/050	5624
	2.8	120	500	4840	1.0		
	2.3	146	600	4840	0.9		
	1.9	158	750	4840	0.8		
	1.6	177	900	4840	0.7	NMRV030/063	5624
	1.6	188	900	6270	1.0		
	1.2	222	1200	6270	0.9		
	0.9	259	1500	6270	0.7		
	0.9	305	1500	7380	1.1	NMRV040/075	5624
	0.8	331	1800	7380	1.0		
	0.6	400	2400	7380	0.7		
	0.5	494	3000	8180	0.9		
	0.4	589	4000	8180	0.8	NMRV040/090	5624
0.12	4.7	112	300	4840	1.2	NMRV030/050	6314

NMRV联体型 性能参数
Performance parameter

P1n KW	n2 r/min	M2n Nm	i	Fr2	fs	减速器型号	电机型号
				N			
0.12	3.5	138	400	4840	0.9	NMRV030/050	6314
	2.8	160	500	4840	0.7		
	2.8	168	500	6270	1.3	NMRV030/063	6314
	2.3	199	600	6270	1.1		
	1.9	217	750	6270	0.9		
	1.6	279	900	7380	1.2		
	1.2	344	1200	7380	0.9	NMRV040/075	6314
	0.8	470	1800	8180	0.8	NMRV040/090	6314
	0.6	593	2400	8180	0.9		
	0.5	731	3000	10320	1.1		
	0.4	884	4000	10320	1.0		
	0.3	1023	5000	10320	0.8	NMRV050/105	6314
	0.5	731	3000	10320	1.2		
	0.4	884	4000	10320	1.0		
0.3	1023	5000	10320	0.8			
0.18	3.5	216	400	6270	1.0	NMRV030/063	6324
	2.8	525	500	6270	0.8		
	2.3	336	600	7380	1.1	NMRV040/075	6324
	1.9	371	750	7380	0.9		
	1.6	419	900	7380	0.8		
	1.2	544	1200	8180	1.0		
	0.9	647	1500	8180	0.8	NMRV040/090	6324
	0.8	727	1800	10320	1.3	NMRV050/105	6324
	0.6	948	2400	10320	0.9		

NMRV联体型 性能参数
Performance parameter

P1n KW	n2 r/min	M2n Nm	i	Fr2	fs	减速器型号	电机型号		
				N					
0.18	0.8	727	1800	10320	1.5	NMRV050/110	6324		
	0.6	948	2400	10320	1.1				
0.25	7	150	400	6270	1.4	NMRV030/063	6322		
	5.6	175	500	6270	1.2				
	3.5	321	400	7380	1.1	NMRV040/075	7114		
	2.8	375	500	7380	0.8				
	2.3	488	600	8180	1.2	NMRV040/090	7114		
	1.9	553	750	8180	0.9				
	1.6	612	900	8180	0.8				
	1.2	776	1200	10320	1.1				
	0.37	0.9	924	1500	10320	1.0	NMRV050/105	7114	
		0.8	1010	1800	10320	0.9			
1.2		776	1200	10320	1.3	NMRV050/110	7114		
0.9		924	1500	10320	1.2				
0.8		1010	1800	10320	1.1				
0.6		1358	2400	103500	1.0				
0.55		0.5	1626	3000	13500	0.8	NMRV063/130	7114	
		0.4	1910	4000	13500	0.6			
		0.3	2132	5000	13500	0.5			
		4.7	383	300	7380	1.0			NMRV040/075
	3.5	474	400	7380	0.7				
0.75	4.7	406	300	8180	1.5	NMRV040/090	7124		
	3.5	505	400	8180	1.2				
	2.8	593	500	8180	0.9				

NMRV联体型 性能参数
Performance parameter

P1n KW	n2 r/min	M2n Nm	i	Fr2	fs	减速器型号	电机型号	
				N				
0.37	2.3	722	600	8180	0.8	NMRV040/090	7124	
	1.9	837	750	10320	1.2			
	1.6	928	900	10320	1.0	NMRV050/105	7124	
	1.2	1148	1200	10320	0.7			
	1.9	837	750	10320	1.3	NMRV050/105	7124	
	1.6	928	900	10320	1.2			
	1.2	1148	1200	10320	0.8			
	0.9	1444	1500	13500	1.1			
	0.55	0.8	1586	1800	13500	0.9	NMRV050/110	8014
		4.7	615	300	10320	1.7		
3.5		810	400	10320	1.2			
2.8		938	500	10320	1.0			
2.3		1096	600	10320	0.9	NMRV050/110	8014	
1.9		1244	750	10320	0.8			
4.7		615	300	10320	2.0	NMRV050/110	8014	
3.5		810	400	10320	1.4			
2.8		938	500	10320	1.1			
2.3		1096	600	10320	1.0			
0.75	1.9	1244	750	10320	0.9	NMRV050/110	8014	
	2.8	957	500	13500	1.6			
	1.9	1382	750	13500	1.2	NMRV063/130	8014	
	1.2	2057	1200	13500	0.8			
	4.7	838	300	10320	1.3	NMRV050/105	8024	
3.5	1105	400	10320	0.9				

NMRV联体型 性能参数
Performance parameter

P1n	n2	M2n	i	Fr2	fs	减速器型号	电机型号
KW	r/min	Nm		N			
0.75	7	553	400	10320	2.1	NMRV050/105	8024
	5.6	640	500	10320	1.6		
1.1	4.7	838	300	10320	1.5	NMRV050/110	8024
	3.5	1105	400	10320	1.1		
	2.8	1305	500	13500	1.1	NMRV063/130	8024
	2.3	1157	600	13500	1.0		
	1.9	1772	750	13500	0.9		
	1.6	2014	900	13500	0.8		
	4.7	1274	300	13500	1.3		
	3.5	1621	400	13500	1.0		
	2.8	1913	500	13500	0.8		
	1.5	4.7	1737	300	13500	1.0	NMRV063/130
3.5		2210	400	13500	0.7		

NRV+NMRV联体型 性能参数
Performance parameter

NRV+NMRV性能参数/performance parameter							
M2n	n1	i	P1n	n2	Fr2	Fr1	减速器型号
Nm	r/min		KW	r/min	N	N	
73	1400	300	0.08	4.7	3490	210	NRV030/040
65	1400	400	0.06	3.5	3490	210	
145	1400	300	0.16	4.7	4840	210	NRV030/050
124	1400	400	0.11	3.5	4840	210	
120	1400	500	0.09	2.8	4840	210	
145	1400	600	0.09	2.3	4840	210	
145	1400	750	0.08	1.9	4840	210	
145	1400	900	0.07	1.6	4840	210	
124	1400	1200	0.05	1.2	4840	210	NRV030/063
145	1400	1500	0.05	0.93	4840	210	
145	1400	1800	0.05	0.78	4840	210	
230	1400	300	0.24	4.7	6270	210	
230	1400	400	0.19	3.5	6270	210	
216	1400	500	0.15	2.8	6270	210	
230	1400	600	0.14	2.3	6270	210	
216	1400	750	0.12	1.9	6270	210	
198	1400	900	0.09	1.6	6270	210	
230	1400	1200	0.09	1.2	6270	210	
216	1400	1500	0.08	0.93	6270	210	
198	1400	1800	0.06	0.78	6270	210	
230	1400	2400	0.06	0.58	6270	210	
216	1400	3000	0.05	0.47	6270	210	

NRV+NMRV联体型 性能参数
Performance parameter

NRV性能参数/performance parameter							
M2n	n1	i	P1n	n2	Fr2	Fr1	减速器型号
Nm	r/min		KW	r/min	N	N	
390	1400	300	0.38	4.7	7380	350	NRV040/075
360	1400	400	0.28	3.5	7380	350	
320	1400	500	0.21	2.8	7380	350	
390	1400	600	0.21	2.3	7380	350	
390	1400	750	0.19	1.9	7380	350	
390	1400	900	0.17	1.6	7380	350	
360	1400	1200	0.13	1.2	7380	350	
390	1400	1500	0.12	0.93	7380	350	
390	1400	1800	0.11	0.78	7380	350	
360	1400	2400	0.08	0.58	7380	350	
320	1400	3000	0.06	0.47	7380	350	
610	1400	300	0.56	4.7	8180	350	NRV040/090
610	1400	400	0.45	3.5	8180	350	
560	1400	500	0.35	2.8	8180	350	
610	1400	600	0.31	2.3	8180	350	
560	1400	750	0.25	1.9	8180	350	
505	1400	900	0.21	1.6	8180	350	
610	1400	1200	0.2	1.2	8180	350	
560	1400	1500	0.16	0.93	8180	350	
505	1400	1800	0.13	0.78	8180	350	
610	1400	2400	0.12	0.58	8180	350	
560	1400	3000	0.1	0.47	8180	350	

NRV+NMRV联体型 性能参数
Performance parameter

NRV性能参数/performance parameter							
M2n	n1	i	P1n	n2	Fr2	Fr1	减速器型号
Nm	r/min		KW	r/min	N	N	
460	1400	4000	0.07	0.35	8180	350	NRV040/090
410	1400	5000	0.05	0.28	8180	350	
1100	1400	300	1	4.7	10320	490	NRV050/105
1030	1400	400	0.7	3.5	10320	490	
1000	1400	500	0.49	2.8	10320	490	
1030	1400	600	0.52	2.3	10320	490	
1100	1400	750	0.49	1.9	10320	490	
1100	1400	900	0.44	1.6	10320	490	
1030	1400	1200	0.33	1.2	10320	490	
1100	1400	1500	0.3	0.93	10320	490	
1100	1400	1800	0.27	0.78	10320	490	
1030	1400	2400	0.02	0.58	10320	490	
1000	1400	3000	0.16	0.47	10320	490	NRV050/110
780	1400	4000	0.11	0.35	10320	490	
710	1400	5000	0.09	0.28	10320	490	
1265	1400	300	1.1	4.7	10320	490	
1185	1400	400	0.8	3.5	10320	490	
1100	1400	500	0.54	2.8	10320	490	
1185	1400	600	0.59	2.3	10320	490	
1265	1400	750	0.56	1.9	10320	490	
1265	1400	900	0.5	1.6	10320	490	
1185	1400	1200	0.38	1.2	10320	490	

NRV+NMRV联体型 性能参数
Performance parameter

NRV性能参数/performance parameter							
M2n	n1	i	P1n	n2	Fr2	Fr1	减速器型号
Nm	r/min		KW	r/min	N	N	
1265	1400	1500	0.34	0.93	10320	490	NRV050/110
1265	1400	1800	0.31	0.78	10320	490	
1185	1400	2400	0.22	0.58	10320	490	
1100	1400	3000	0.18	0.47	10320	490	
819	1400	4000	0.11	0.35	10320	490	
746	1400	5000	0.09	0.28	10320	490	
1765	1400	300	1.5	4.7	10350	700	
1650	1400	400	1.1	3.5	10350	700	
1550	1400	500	0.89	2.8	10350	700	
1650	1400	600	0.79	2.3	10350	700	
1760	1400	750	0.75	1.9	10350	700	
1760	1400	900	0.66	1.6	10350	700	
1650	1400	1200	0.51	1.2	10350	700	
1760	1400	1500	0.45	0.93	10350	700	
1760	1400	1800	0.41	0.78	10350	700	
1650	1400	2400	0.3	0.58	10350	700	
1550	1400	3000	0.24	0.47	10350	700	
1220	1400	4000	0.16	0.35	10350	700	
1100	1400	5000	0.13	0.28	10350	700	

