

Centrifugal pumps

-  Clean water
-  Domestic use
-  Civil use



PERFORMANCE RANGE

- Flow rate up to **160 l/min** (9.6 m³/h)
- Head up to **56 m**

APPLICATION LIMITS

- Manometric suction lift up to **7 m**
- Liquid temperature between **-10 °C** and **+90 °C**
- Ambient temperature up to **+40 °C**
- Max. working pressure:
 - **6 bar** for CP 100-130-132-150-158
 - **10 bar** for CP 170-190-200
- Continuous service **S1**

CONSTRUCTION AND SAFETY STANDARDS

EN 60335-1
IEC 60335-1
CEI 61-150

EN 60034-1
IEC 60034-1
CEI 2-3



EU REGULATION N. 547/2012

INSTALLATION AND USE

Suitable for use with clean water and with liquids that are not chemically aggressive towards the materials from which the pump is made. Because they are reliable and easy to use these pumps are widely used in domestic and civil applications such as the distribution of water in combination with small and medium sized pressure tanks, for transferring liquids and for the irrigation of gardens and orchards.

The pump should be installed in an enclosed environment or sheltered from inclement weather.

PATENTS - TRADE MARKS - MODELS

- Registered Trade Mark n. 0001516350 CPm158
- Registered EU Design n. 002098434

OPTIONS AVAILABLE ON REQUEST

- Special mechanical seal
- Other voltages or 60 Hz frequency
- IP X5 class protection for CP 170, CP 170M

CERTIFICATIONS

Company with management system certified DNV
ISO 9001: QUALITY
ISO 14001: ENVIRONMENT



CHARACTERISTIC CURVES AND PERFORMANCE DATA

50 Hz n= 2900 rpm HS= 0 m

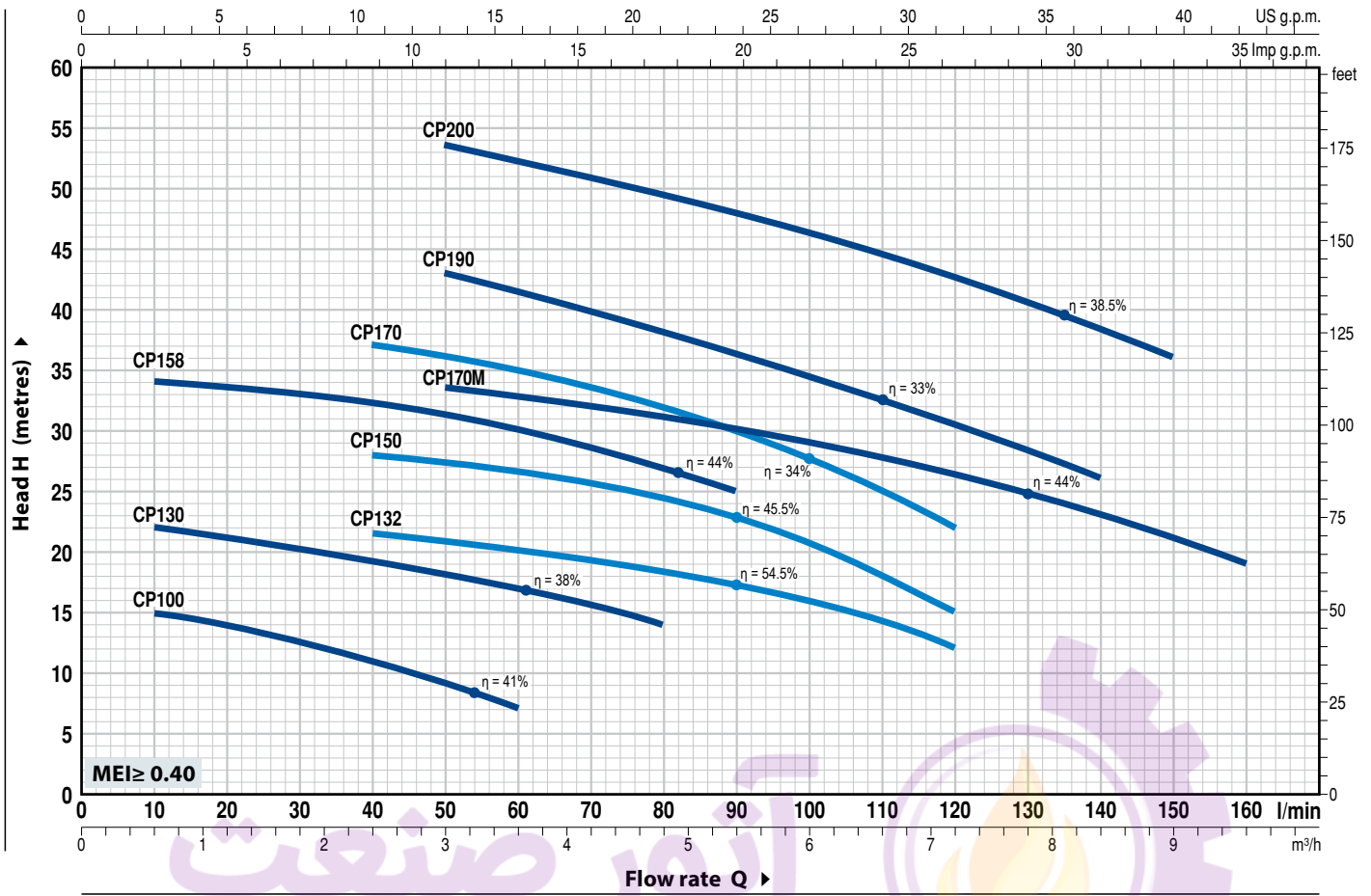

MODEL		POWER (P ₂)		Q	Flow rate																		
Single-phase	Three-phase	kW	HP ▲		m ³ /h	0	0.6	1.2	1.8	2.4	3.0	3.6	4.2	4.8	5.4	6.0	6.6	7.2	7.8	8.4	9.0	9.6	
				l/min	0	10	20	30	40	50	60	70	80	90	100	110	120	130	140	150	160		
CPm 100	CP 100	0.25	0.33	H metres	16	15	14	12.5	11	9	7												
CPm 130	CP 130	0.37	0.50		23	22	21	20	19	18	17	15.5	14										
CPm 132	CP 132	0.55	0.75		23	-	22.5	22	21.5	21	20.5	19.5	18.5	17.5	16	14	12						
CPm 150	CP 150	0.75	1		29.5	-	29	28.5	28	27.5	26.5	26	24.5	23	21	18	15						
CPm 158	CP 158	0.75	1		36	34	33.5	33	32.5	31.5	30	28.5	27	25									
CPm 170	CP 170	1.1	1.5		41	-	-	38	37	36	35	33.5	32	30	27.5	25	22						
CPm 170M	CP 170M	1.1	1.5		36	-	-	35	34.5	33.5	33	32	31	30	29	28	26.5	25	23	21	19		
CPm 190	CP 190	1.5	2		48	-	-	46	44.5	43	41.5	40	38	36	34.5	32.5	30.5	28	26				
-	CP 200	2.2	3	IE3	56	-	-	55	54.5	53.5	52	51	49.5	48	46	44.5	42.5	40.5	38.5	36			

Q = Flow rate H = Total manometric head HS = Suction height

Tolerance of characteristic curves in compliance with EN ISO 9906 Grade 3B.

▲ Performance class of the three-phase motor (IEC-60034-30)

POS. COMPONENT CONSTRUCTION CHARACTERISTICS

1 PUMP BODY	Cast iron with an Epoxy Electro Coating treatment, with threaded ports in compliance with ISO 228/1					
2 BODY BACKPLATE	Stainless steel AISI 304 (cast iron for CP 170-170M-190-200)					
3 IMPELLER	Stainless steel AISI 304					
4 MOTOR SHAFT	Stainless steel EN 10088-3 - 1.4104					
5 MECHANICAL SEAL	Pump	Seal	Shaft	Materials		
	<i>Model</i>	<i>Model</i>	<i>Diameter</i>	<i>Stationary ring</i>	<i>Rotational ring</i>	<i>Elastomer</i>
	CP 100-130-132	AR-12	Ø 12 mm	Ceramic	Graphite	NBR
	CP 150-158	AR-14	Ø 14 mm	Ceramic	Graphite	NBR
	CP 170-170M-190-200	FN-18	Ø 18 mm	Graphite	Ceramic	NBR
6 BEARINGS	Pump	Model				
	CP 100-130-132	6201 ZZ / 6201 ZZ				
	CP 150-158	6203 ZZ / 6203 ZZ				
	CP 170-170M	6204 ZZ / 6204 ZZ				
	CP 190-200	6304 ZZ / 6204 ZZ				
7 CAPACITOR	Pump	Capacitance				
	<i>Single-phase</i>	<i>(230 V or 240 V)</i>		<i>(110 V)</i>		
	CPm 100	10 µF - 450 VL	25 µF - 250 VL			
	CPm 130	10 µF - 450 VL	25 µF - 250 VL			
	CPm 132	14 µF - 450 VL	25 µF - 250 VL			
	CPm 150-158	20 µF - 450 VL	60 µF - 300 VL			
	CPm 170-170M	25 µF - 450 VL	60 µF - 250 VL			
	CPm 190	45 µF - 450 VL	80 µF - 250 VL			
8 ELECTRIC MOTOR	CPm: single-phase 230 V - 50 Hz with thermal overload protector incorporated into the winding.					
	CP: three-phase 230/400 V - 50 Hz.					
	<p>➔ The three-phase pumps are fitted with high performance motors up to P2=1.1kW in class IE2 and from P2=1.5kW in class IE3 (IEC 60034-30)</p> <ul style="list-style-type: none"> - Insulation: class F - Protection: IP X4 					

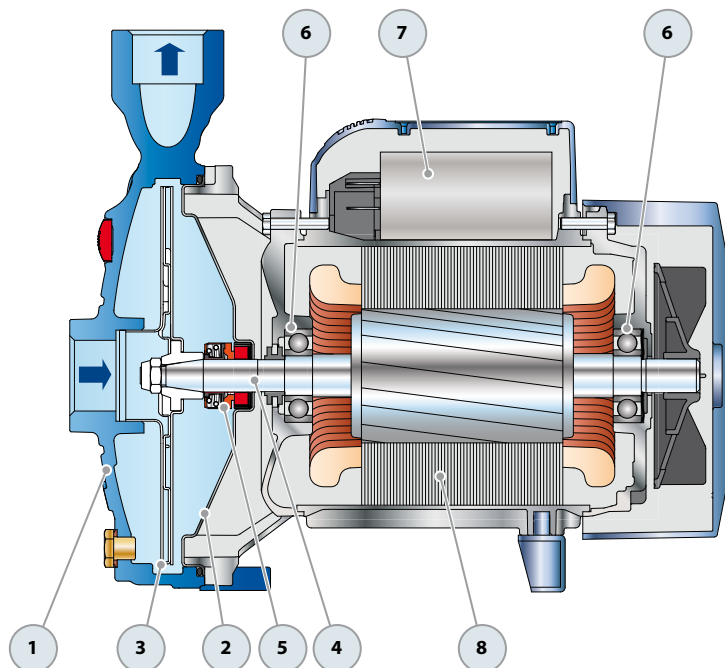

DIMENSIONS AND WEIGHT

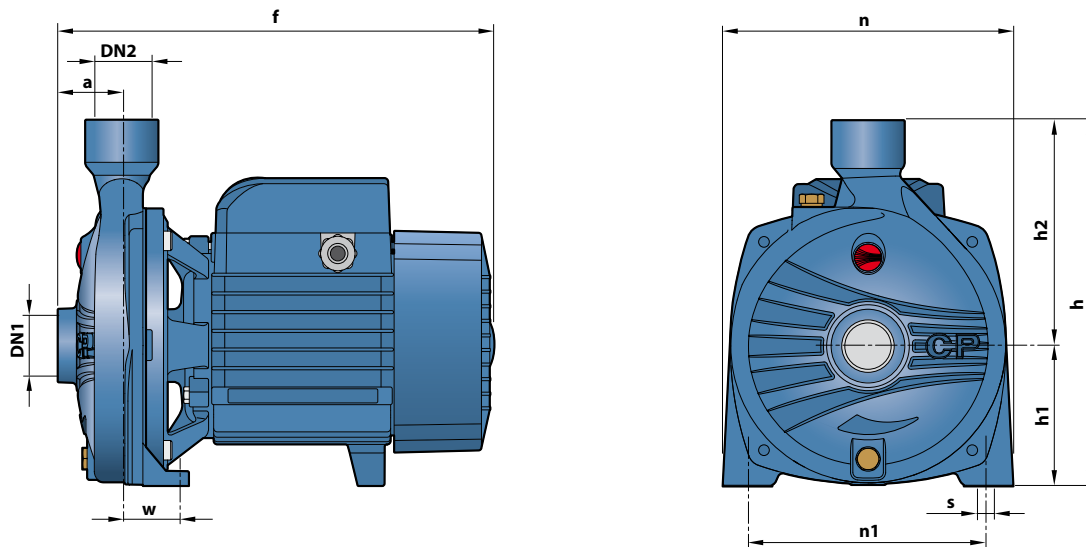

MODEL		PORTS		DIMENSIONS mm								kg		
Single-phase	Three-phase	DN1	DN2	a	f	h	h1	h2	n	n1	w	s	1~	3~
CPm 100	CP 100	1"	1"	42	253	205	82	123	165	135	41	10	7.1	7.1
CPm 130	CP 130												7.8	7.3
CPm 132	CP 132												8.7	8.2
CPm 150	CP 150			285	240	92	148	190	160	38	12.4		11.4	
CPm 158	CP 158			12.0	11.0									
CPm 170 - 170M	CP 170 - 170M	1 1/4"	1"	51	367	260	110	150	206	165	44.5	11	17.8	17.2
CPm 190	CP 190			48	364	290	115	175	242	206	36.5		21.3	20.3
-	CP 200	-	-	-	-	-	-	-	-	-	-	-	-	21.5

ABSORPTION

MODEL	VOLTAGE		
Single-phase	230 V	240 V	110 V
CPm 100	1.9 A	1.55 A	3.3 A
CPm 130	3.2 A	2.9 A	6.4 A
CPm 132	3.9 A	3.7 A	7.0 A
CPm 150	5.7 A	5.4 A	11.4 A
CPm 158	6.0 A	5.8 A	12.0 A
CPm 170 - 170M	7.8 A	7.2 A	16.0 A
CPm 190	11.0 A	10.0 A	22.0 A

MODEL	VOLTAGE			
Three-phase	230 V	400 V	240 V	415 V
CP 100	1.7 A	1.0 A	1.6 A	0.9 A
CP 130	2.0 A	1.2 A	1.8 A	1.1 A
CP 132	2.4 A	1.4 A	2.3 A	1.3 A
CP 150	4.2 A	2.4 A	4.1 A	2.3 A
CP 158	4.4 A	2.5 A	4.3 A	2.4 A
CP 170 - 170M	5.2 A	3.0 A	5.1 A	2.9 A
CP 190	7.5 A	4.3 A	7.3 A	4.2 A
CP 200	9.3 A	5.4 A	9.0 A	5.2 A

PALLETIZATION

MODEL		GROUPAGE	CONTAINER
Single-phase	Three-phase	n. pumps	n. pumps
CPm 100	CP 100	90	162
CPm 130	CP 130	90	162
CPm 132	CP 132	90	162
CPm 150	CP 150	70	112
CPm 158	CP 158	70	112
CPm 170	CP 170	50	70
CPm 170M	CP 170M	50	70
CPm 190	CP 190	36	54
-	CP 200	36	54