



Application

- It is applicable to household water supply, equipment support, pipeline pressurization, garden watering, vegetable greenhouse watering, fish farming and poultry raising, industrial and mining, water supply and drainage of enterprises and high-rise buildings, central air conditioner and centralized heating circulation system, etc.

Pump

- AISI 304 pump body
- AISI 304 shaft
- Max. liquid temperature: +85°C
- Altitude: up to 1000 m

Motor

- C&U bearing
- Motor with copper winding
- Built-in thermal protector for single phase motor
- Insulation class: F
- Protection class: IPX4
- Max. temperature: +40°C

Identification Codes

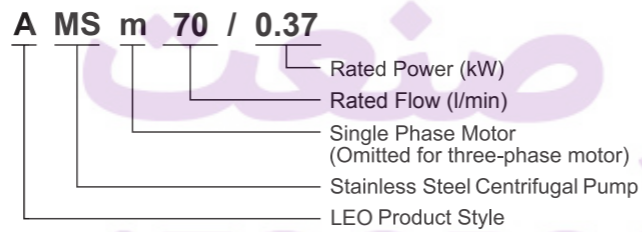

Hydraulic Performance Curves

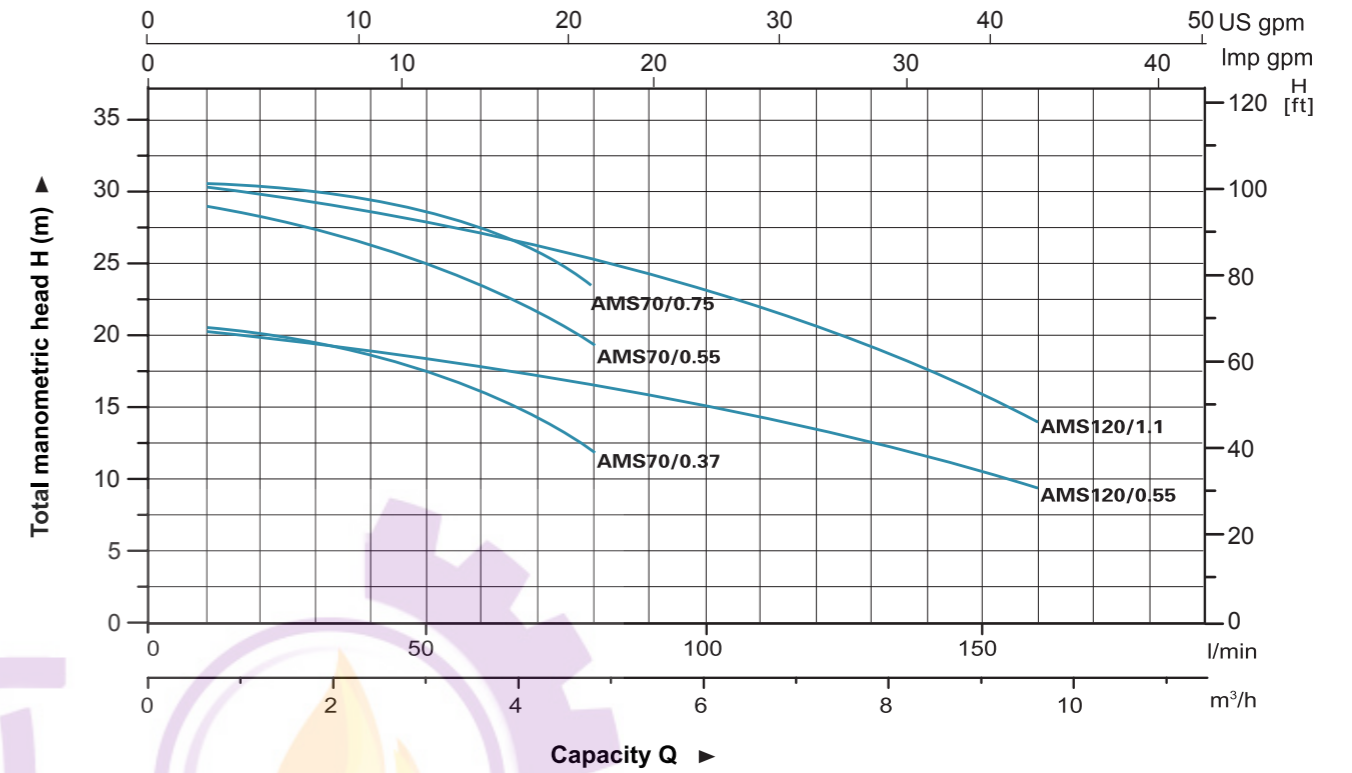

Materials Table

No.	Part	Material
1	Bottom support	Steel
2	Pump body	AISI 304
3	Diffuser	AISI 304
4	Impeller	AISI 304
5	O-ring	NBR
6	Airproof plate	AISI 304
7	Support	ZL102
8	Mechanical seal	Silicon/carbon
9	Ball bearing	
10	Rotor	
11	Stator	
12	Fan	PP
13	Rear housing	ZL102
14	Fan cover	PP
15	Terminal box	ABS

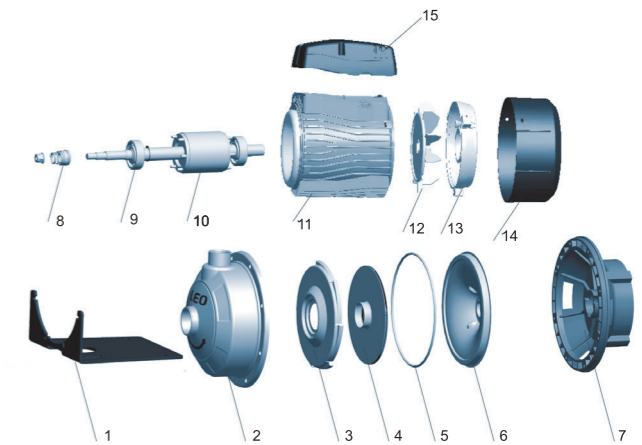

Technical Data

MODEL		POWER		I/min	0	30	40	60	80	100	120	140	160	180	
Single Phase	Three Phase	kW	HP	m³/h	0	1.8	2.4	3.6	4.8	6	7.2	8.4	9.6	10.8	
AMSm70/0.37	AMS70/0.37	0.37	0.5	H (m)	20.9	19.0	18.1	15.7	12.1	-	-	-	-	-	
AMSm70/0.55	AMS70/0.55	0.55	0.75		29.5	27.3	26.3	23.4	19.1	-	-	-	-	-	-
AMSm70/0.75	AMS70/0.75	0.75	1.0		30.4	28.5	27.8	26.0	23.0	-	-	-	-	-	-
AMSm120/0.55	AMS120/0.55	0.55	0.75		20.2	-	-	17.9	16.6	15.1	13.3	11.2	8.7	-	-
AMSm120/1.1	AMS120/1.1	1.1	1.5		30.2	-	-	26.7	25.1	23.3	21.2	19.0	16.4	-	-

Dimension

Model	Ports		L (mm)	W (mm)	H (mm)	L ₁ (mm)	L ₂ (mm)	W ₁ (mm)	H ₁ (mm)
	DN1	DN2							
AMS70/0.37	1 1/4"	1"	332	210	224	119	55	149	110
AMS70/0.55	1 1/4"	1"	332	210	224	119	55	149	110
AMS70/0.75	1 1/4"	1"	381	210	234	119	55	149	110
AMS120/0.55	1 1/4"	1"	332	210	224	119	55	149	110
AMS120/1.1	1 1/4"	1"	381	210	234	119	55	149	110

Package Information

Model	GW (Kgs)	L (mm)	W (mm)	H (mm)	Quantity (PCS/20 TEU)
AMS70/0.37	10	380	240	270	1200
AMS70/0.55	11	380	240	270	1200
AMS70/0.75	14	410	240	270	1104
AMS120/0.55	11	380	240	270	1200
AMS120/1.1	15	410	240	270	1104

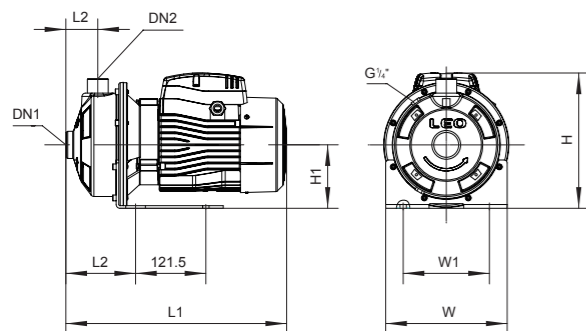
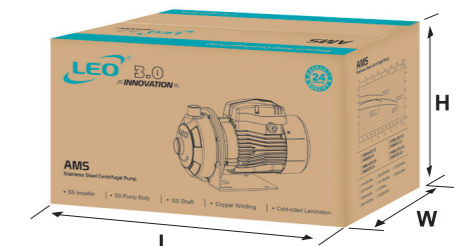



Application

- It is applicable to household water supply, equipment support, pipeline pressurization, garden watering, vegetable greenhouse watering, fish farming and poultry raising, industrial and mining, water supply and drainage of enterprises and high-rise buildings, central air conditioner and centralized heating circulation system, etc.

Pump

- AISI 304 pump body
- AISI 304 shaft
- Max. liquid temperature: +85°C
- Altitude: up to 1000 m

Motor

- C&U bearing
- Motor with copper winding
- Built-in thermal protector for single phase motor
- Insulation class: F
- Protection class: IPX4
- Max. temperature: +40°C

Identification Codes

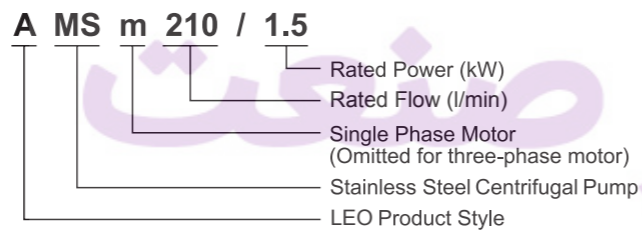

Technical Data

MODEL		POWER		Capacity Q																
Single Phase	Three Phase	kW	HP	I/min																
				0	30	60	100	120	140	160	180	200	250	300	350	400	430	480	520	
AMSm210/0.75	AMS210/0.75	0.75	1.0	16.8	-	-	-	15.6	15.2	14.8	14.2	13.6	11.9	9.8	-	-	-	-	-	
AMSm210/1.1	AMS210/1.1	1.1	1.5	19.7	-	-	-	18.7	18.3	18.0	17.5	17.1	15.6	13.6	-	-	-	-	-	
AMSm210/1.5	AMS210/1.5	1.5	2.0	24.2	-	-	-	23.5	23.2	22.8	22.4	21.8	20.2	18.0	-	-	-	-	-	
AMSm210/2.2	AMS210/2.2	2.2	3.0	27.5	-	-	-	26.7	26.5	26.1	25.7	25.2	23.8	21.9	-	-	-	-	-	
AMSm370/1.1	AMS370/1.1	1.1	1.5	15.4	-	-	-	-	-	-	14.7	14.4	13.5	12.3	10.8	8.9	7.6	-	-	
AMSm370/1.5	AMS370/1.5	1.5	2.0	19.3	-	-	-	-	-	-	18.1	17.3	16.3	15.0	13.3	12.3	10.2	-	-	
AMSm370/2.2	AMS370/2.2	2.2	3.0	23.1	-	-	-	-	-	-	21.7	20.9	20.0	18.8	17.2	16.2	14.2	12.3	-	

Hydraulic Performance Curves

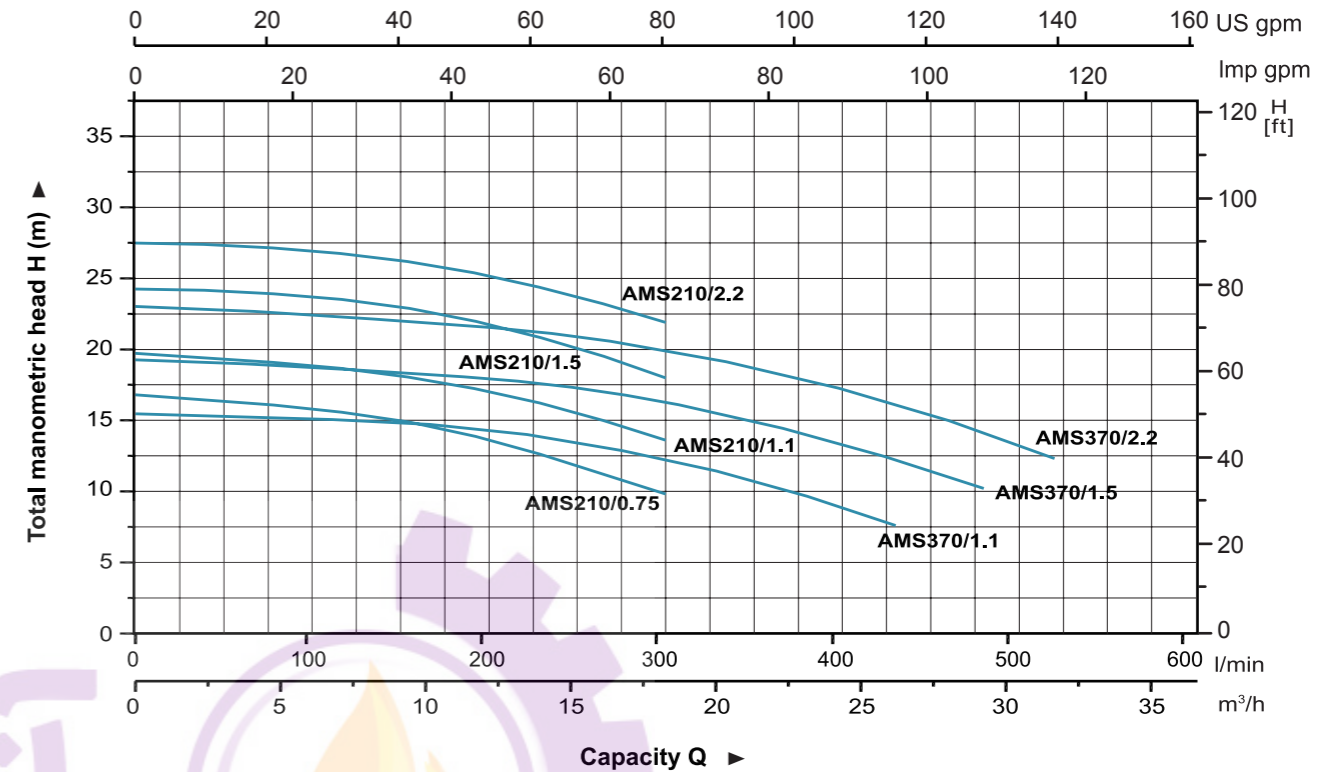

Materials Table

No.	Part	Material
1	Bottom support	Steel
2	Pump body	AISI 304
3	Diffuser	AISI 304
4	Impeller	AISI 304
5	O-ring	NBR
6	Airproof plate	AISI 304
7	Support	ZL102
8	Mechanical seal	Silicon/carbon
9	Ball bearing	
10	Rotor	
11	Stator	
12	Fan	PP
13	Rear housing	ZL102
14	Fan cover	PP
15	Terminal box	ABS

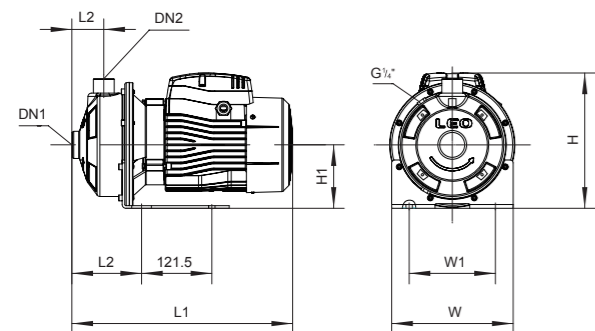
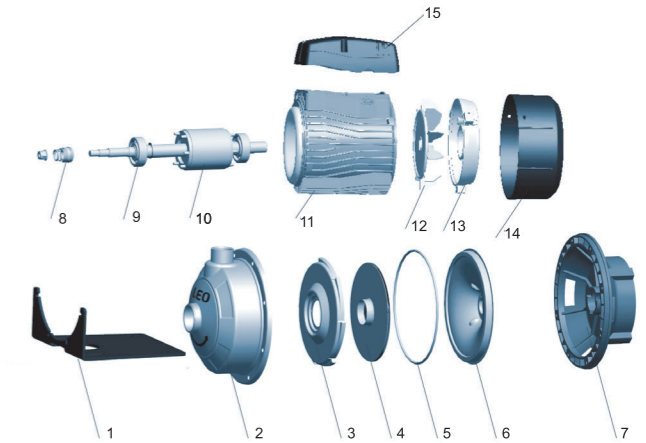

Dimension

Model	Ports		L (mm)	W (mm)	H (mm)	L ₁ (mm)	L ₂ (mm)	W ₁ (mm)	H ₁ (mm)
	DN1	DN2							
AMS210/0.75	1 1/2"	1 1/4"	392	210	234	129	55	149	110
AMS210/1.1	1 1/2"	1 1/4"	392	210	234	129	55	149	110
AMS210/1.5	1 1/2"	1 1/4"	440	210	250	129	55	149	110
AMS210/2.2	1 1/2"	1 1/4"	440	210	250	129	55	149	110
AMS370/1.1	2"	1 1/4"	392	210	234	129	55	149	110
AMS370/1.5	2"	1 1/4"	440	210	250	129	55	149	110
AMS370/2.2	2"	1 1/4"	440	210	250	129	55	149	110

Package Information

Model	GW (Kgs)	L (mm)	W (mm)	H (mm)	Quantity (PCS/20 TEU)
AMS210/0.75	14	410	240	270	1104
AMS210/1.1	15	410	240	270	1104
AMS210/1.5	18	465	240	270	968
AMS210/2.2	20	465	240	270	968
AMS370/1.1	15	410	240	270	1104
AMS370/1.5	18	465	240	270	968
AMS370/2.2	20	465	240	270	968

