



Application

- Circulation and transfer of clean, chemically non-aggressive water and other liquids
- Water supply & irrigation
- Water circulation in air conditioning systems

Operating conditions

- Delivery: up to 220 m³/h
- Head: up to 95 m
- Liquid temperature:
Standard: -10°C to 85°C Upon request: -20°C to 120°C
- Maximum operating pressure: 12 bar (PN12)
Anti-clockwise rotation when facing pump's suction port
- Impeller: AISI304/HT200
- Mechanical seal in compliance with DIN 24960
- Lubricated by internal recirculating pumped liquid
- Counter flange available on request

Motor

- Closed construction, external ventilation
- Insulation class: F
- Protection class: IP54
- Performance in compliance with CEI 2-3 (IEC 34.1)
- Max. ambient temperature: +40°C
- Overload protection

Construction features

- Single-impeller centrifugal pump featuring axial intake and radial discharge
- Inlet and outlet DN in compliance with EN 733 (ex DIN 24255) and UNI 7467
- Flanges in compliance with UNI 2236 and DIN 2532
- Rear entry (impeller, control valve and motor can be extracted without disconnecting the pump body from the pipes)

Accessories on request

- Galvanised iron threaded counter flanges
- Flanged tapered coupling
- Pump and motor sealing gasket

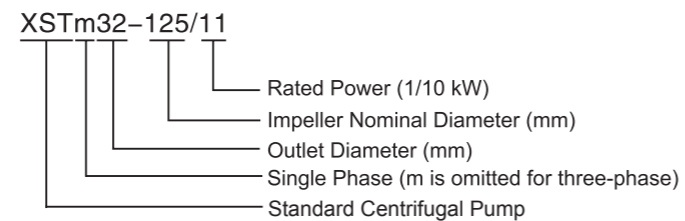

Materials Table

No.	Part	Material
1	Motor	
2	Support	HT 200
3	Pump shaft	Steel/AISI 304
4	Mechanical seal	Carbon/Silicon carbide
5	Impeller	HT 200/Stainless Steel
6	Nut	AISI 304
7	Pump body	HT 200
8	Flange	HT 200

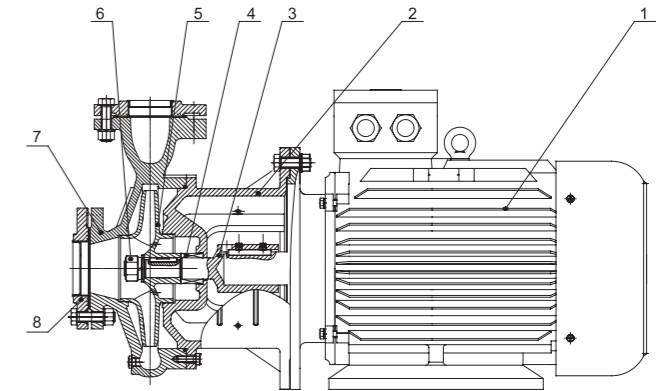

How To Read The Curve Charts

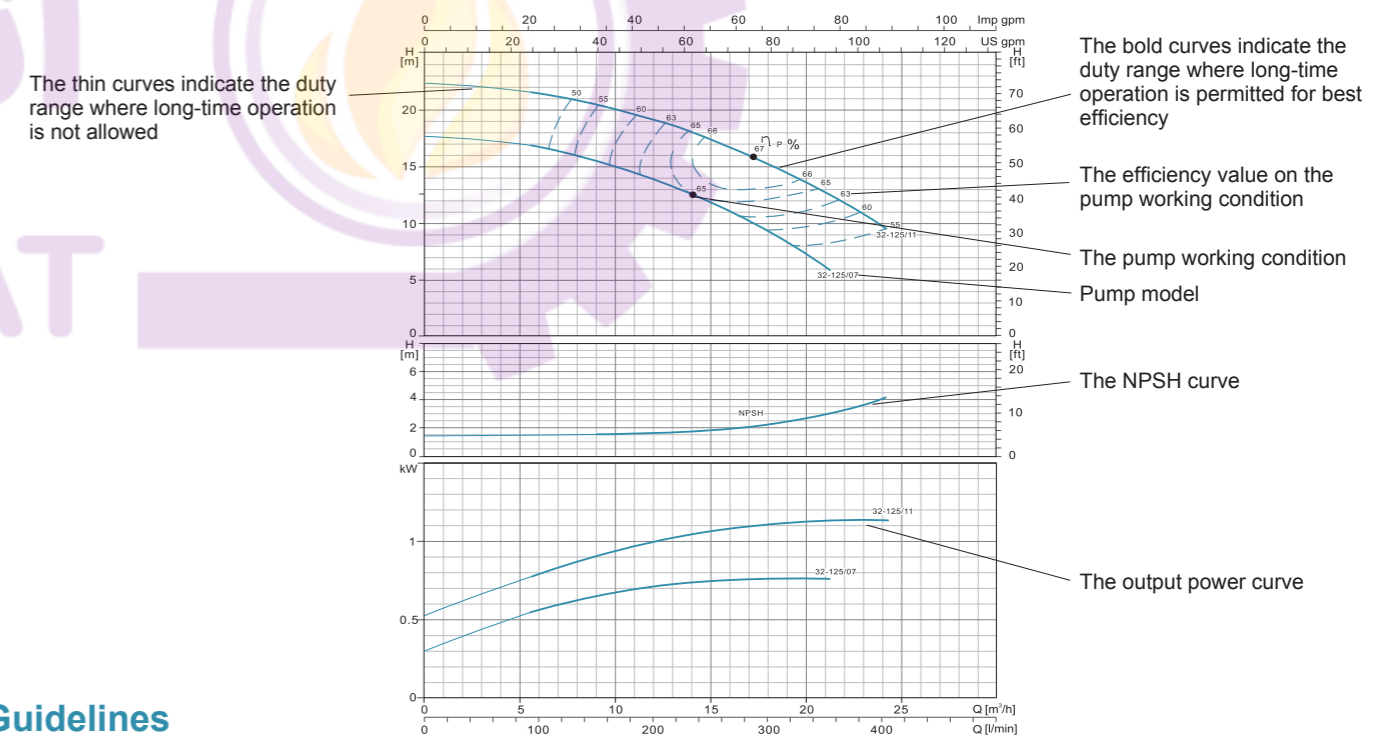

Guidelines to Performance Curves

Tolerances to ISO 9906, Annex A. Measurements have been made with airless water at a temperature of 20°C and kinematic viscosity of 1mm²/s. To avoid overheating of the motor, the pump should not be used against a high head for a long time.

Technical Data

PUMP TYPE	POWER		l/min m ³ /h	Q=DELIVERY																			
	kW	HP		0	100	150	250	300	400	450	600	700	800	900	1200	1400	1500	1800	2000	2300	3000	3500	
32-125/07★	0.75	1	17.5	16.7	15	12	9																
32-125/11★	1.1	1.5	22	21	19.7	16.5	14.5	9															
32-160/15★	1.5	2	25.4	23.7	22.5	18.5	15.8																
32-160/22★	2.2	3	31	29.6	28.5	24.5	22	15															
32-160/30★	3	4	35	34.3	34	28	25.5	19	15														
32-200/30★	3	4	44.2	43	39.8	35.2	32.2	24.6	19.8														
32-200/40★	4	5.5	54.5	52	50	45.5	41.9	35	30.3														
32-250/55★	5.5	7.5	79.5	74.7	71.8	63	56	37.5															
32-250/75★	7.5	10	99.5	95	91.8	83	76	57.8															
40-125/11	1.1	1.5	14.7				13.5	11.5	10.1	5.8													
40-125/15	1.5	2	18.1				17	15	13.9	9.6	6												
40-125/22	2.2	3	24.5				23.2	21.5	20.2	16	13	8.3											
40-160/30	3	4	31.8				29.5	27.5	26.3	21.5	17.5												
40-160/40	4	5.5	38				36	34	33	28.5	25	20.1											
40-200/55★	5.5	7.5	46				43.8	41.3	40.1	35	30												
40-200/75★	7.5	10	57				53.6	51.5	50	45	41	36.5											
40-250/92★	9.2	12.5	64				59	56.5	55	49.5	45	39.8											
40-250/110★	11	15	72				67.5	65	63.5	57.5	52.2	47											
40-250/150★	15	20	84.5				80	77.3	75.2	71	65	61											
50-125/22	2.2	3	17				15.4	14	12.8	11.5	6.5												
50-125/30	3	4	20				18.8	18	17	15.6	11												
50-125/40	4	5.5	24				23.1	23	21.5	20.3	15.8	11.8											
50-160/55	5.5	7.5	32				30.6	30	28	26.6	20.5	14.8											
50-160/75	7.5	10	40				38	37	36	34.4	29	24	21										
50-200/92★	9.2	12.5	50.5				46.8	45	43	40.9	32.5	25.7											
50-200/110★	11	15	57.5				53.5	52	50	47.5	40	33	29										
50-250/150★	15	20	68.5				64	63	61.5	59	50	41											
50-250/185★	18.5	25	77				73.2	72	70	68	60.5	51.5	47										
50-250/220★	22	30	86.3				83	81.5	80.8	78.7	70	61.9	57										
65-125/40	4	5.5	19				17.3	16.8	14.5	13	11.8												
65-125/55	5.5	7.5	23				21.3	20.9	19	17.5	16.7	13.7											
65-125/75	7.5	10	27				26	25.6	24.5	23	22.5	20	18										
65-160/92	9.2	12.5	33				31.5	30	28	27.1	24	21.5											
65-160/110	11	15	36				34.5	33	31.5	30.8	28	25.5											
65-160/150	15	20	42				41	40	38.5	37.8	35	33	29.5										
65-200/150	15	20	45.5				46	43.5	41	39.2	33												
65-200/185	18.5	25	53				53.5	51.2	48.3	47	41.5												
65-200/220	22	30	59				59.5	57.2	54	53	47	43.5											
65-200/185	18.5	25	41.2						42	41.2	40.6	38.2	36.5	34									
65-200/220	22	30	48						48	47.5	46	44	41										
65-200/330	30	40	59.5						59	58.5	58	56.2	54										
65-250/220	22	30	62						61.5	58.2	56.5	54	49	45									
65-250/300	30	40	76						75	73	71.5	69.5	64.5	61.5	54								
65-250/370	37	50	90						88.3	86.5	84	83	78	75	68								
80-160/110	11	15	27									27.3	26	24.5	22.5	16							
80-160/150	15	20	32.8									32.5	31.3	30.2	28.5	22.1	16.7						
80-160/185	18.5	25	39									38	36.8	36.7	33.8	28.8	23.5						
80-200/220	22	30	48									47.5	45.5	43.5	41	32.5	24.5						
80-200/300	30	45	60									59.5	58	57	54.5	47	40.5						
80-250/370	37	50	71.5									70.5	67.5	65.5	61.5	49.5	38.5						
80-250/450	45	61	80									80.5	78.5	76.5	73.4	63.2	51						
80-250/550	55	75	92.5									93.5	91.2	89.8	86.8	77.6	68.3						

★= Stainless steel impeller

Characteristic Curves

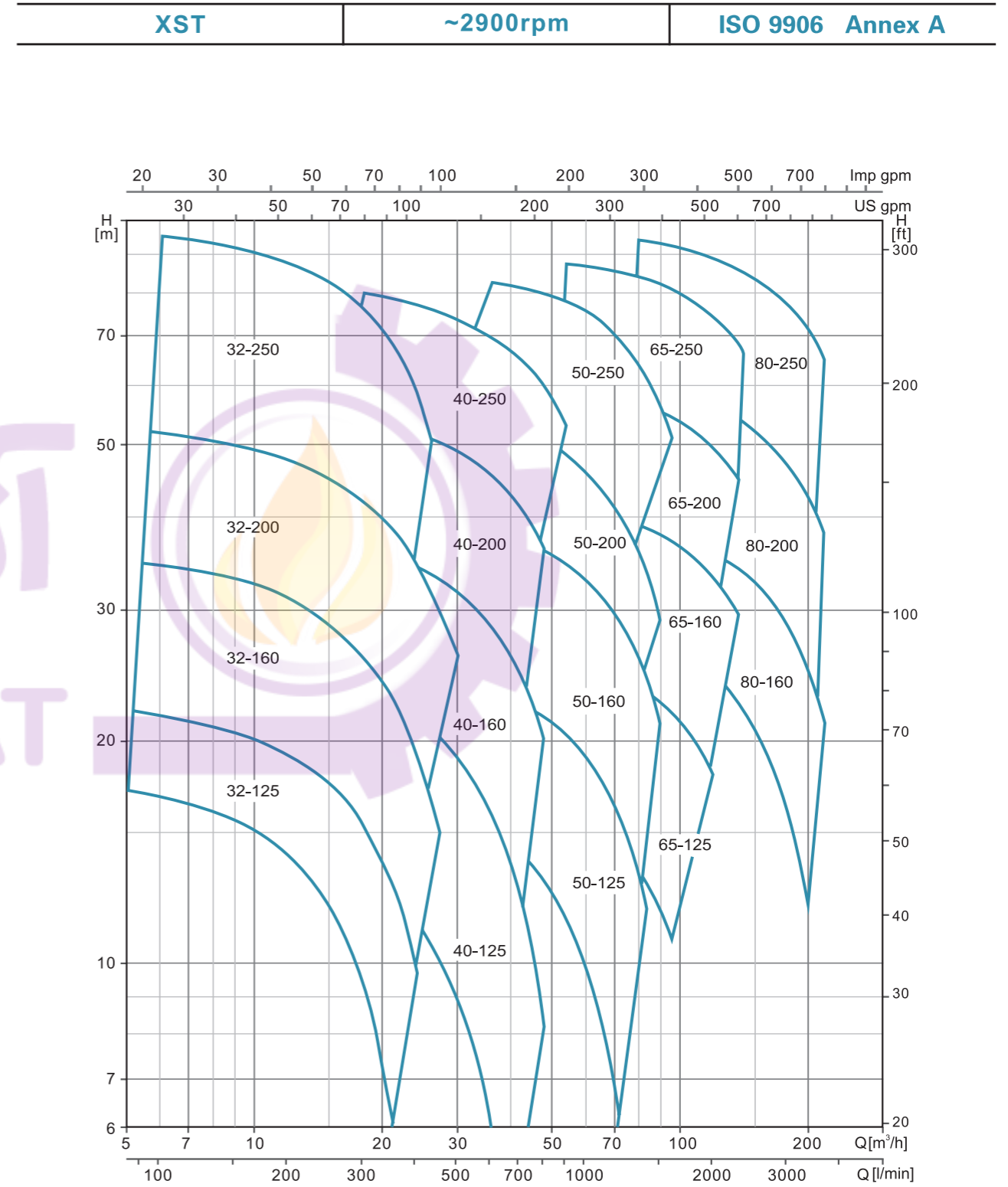

Hydraulic Performance Curves

XST32-125	~2900rpm	ISO 9906 Annex A
-----------	----------	------------------

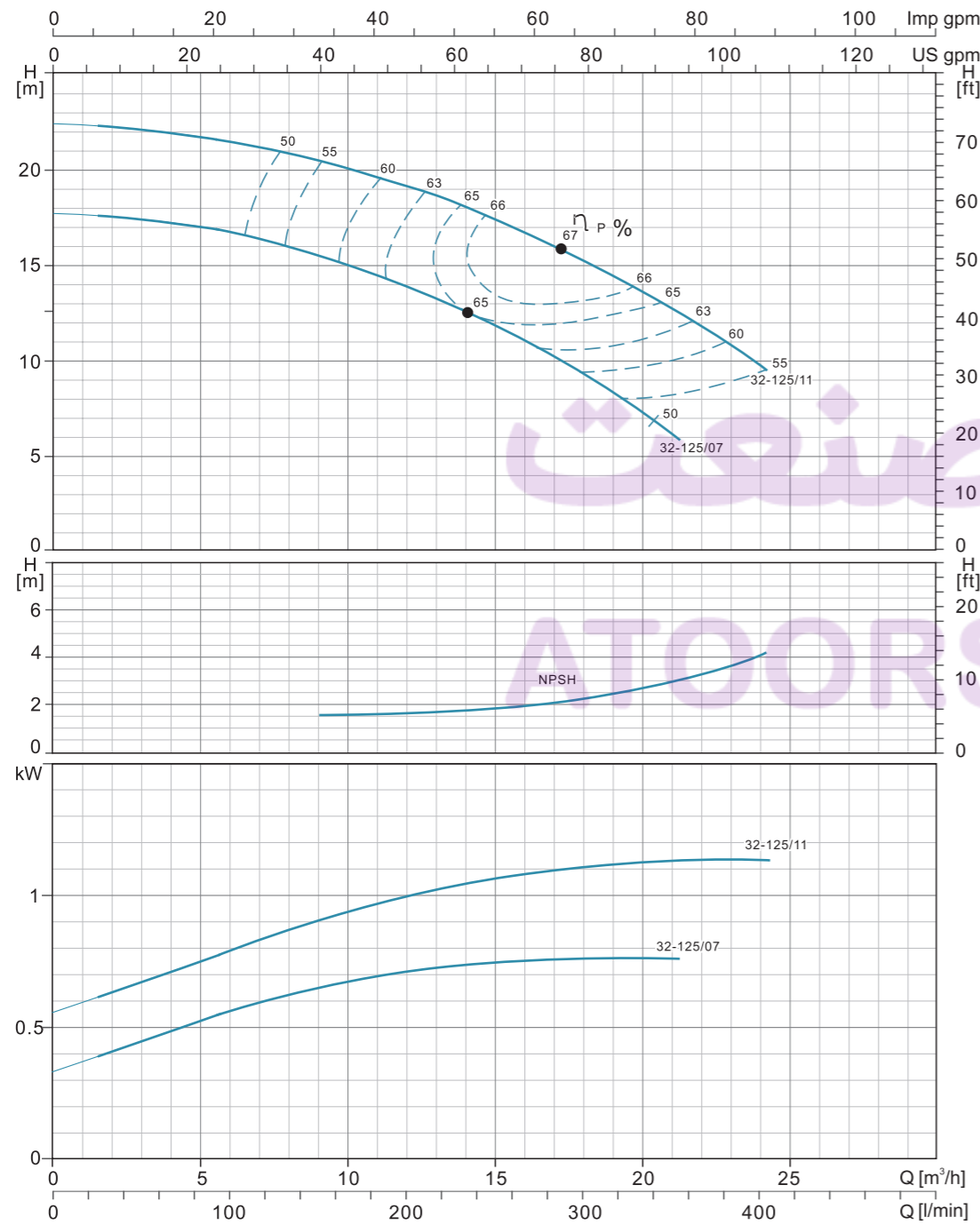

Hydraulic Performance Curves

XST32-160	~2900rpm	ISO 9906 Annex A
-----------	----------	------------------

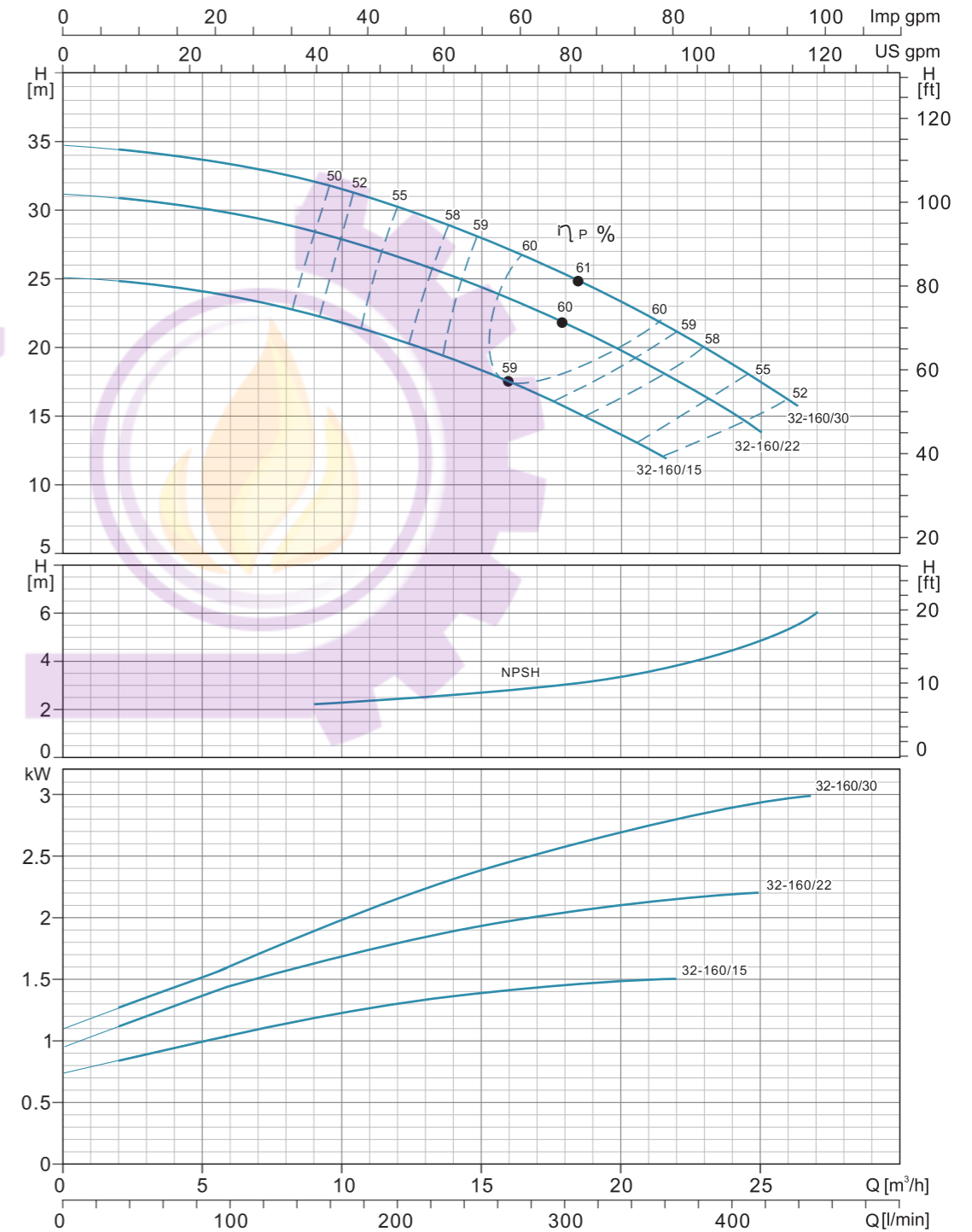

Hydraulic Performance Curves

XST32-200	~2900rpm	ISO 9906 Annex A
-----------	----------	------------------

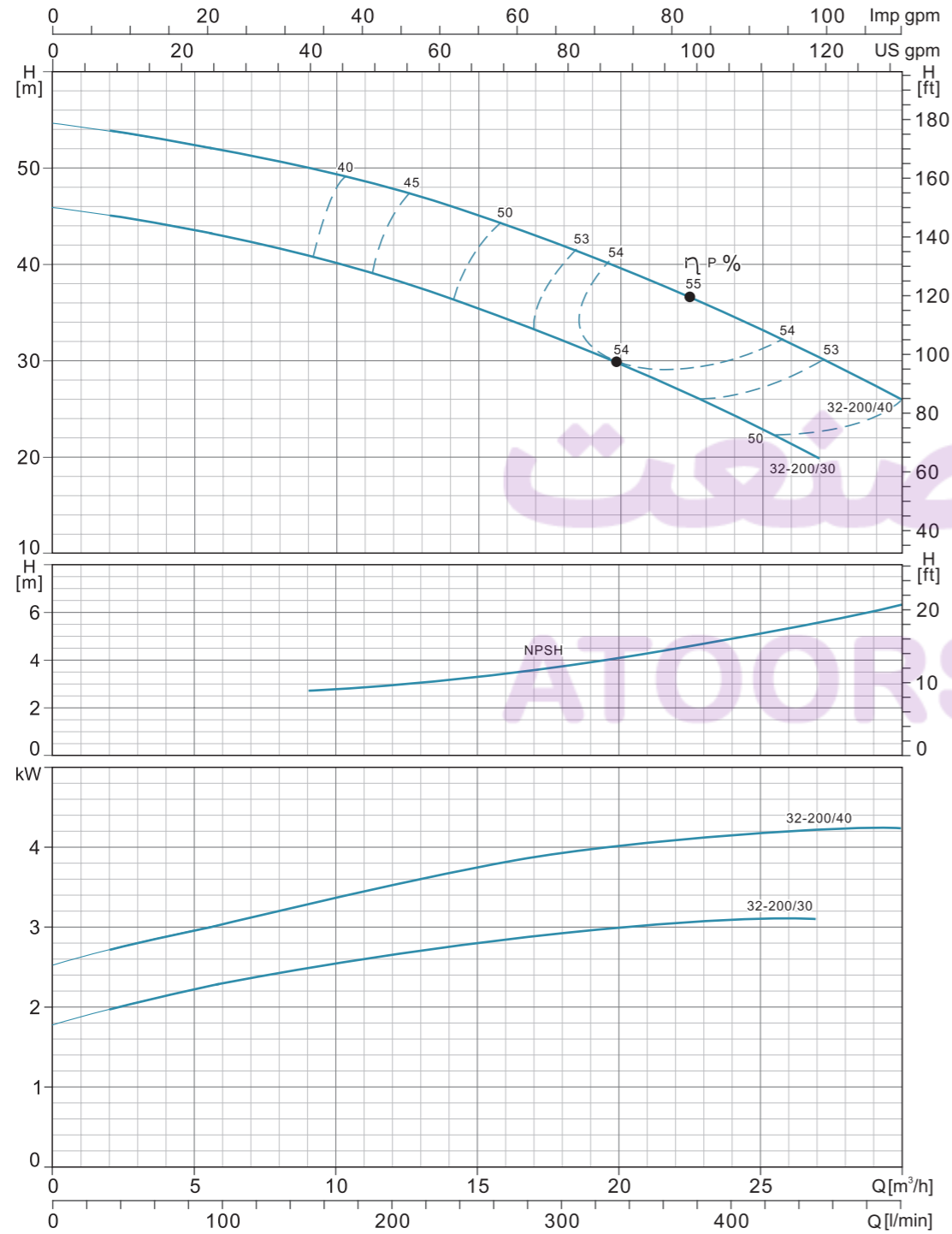

Hydraulic Performance Curves

XST32-250	~2900rpm	ISO 9906 Annex A
-----------	----------	------------------

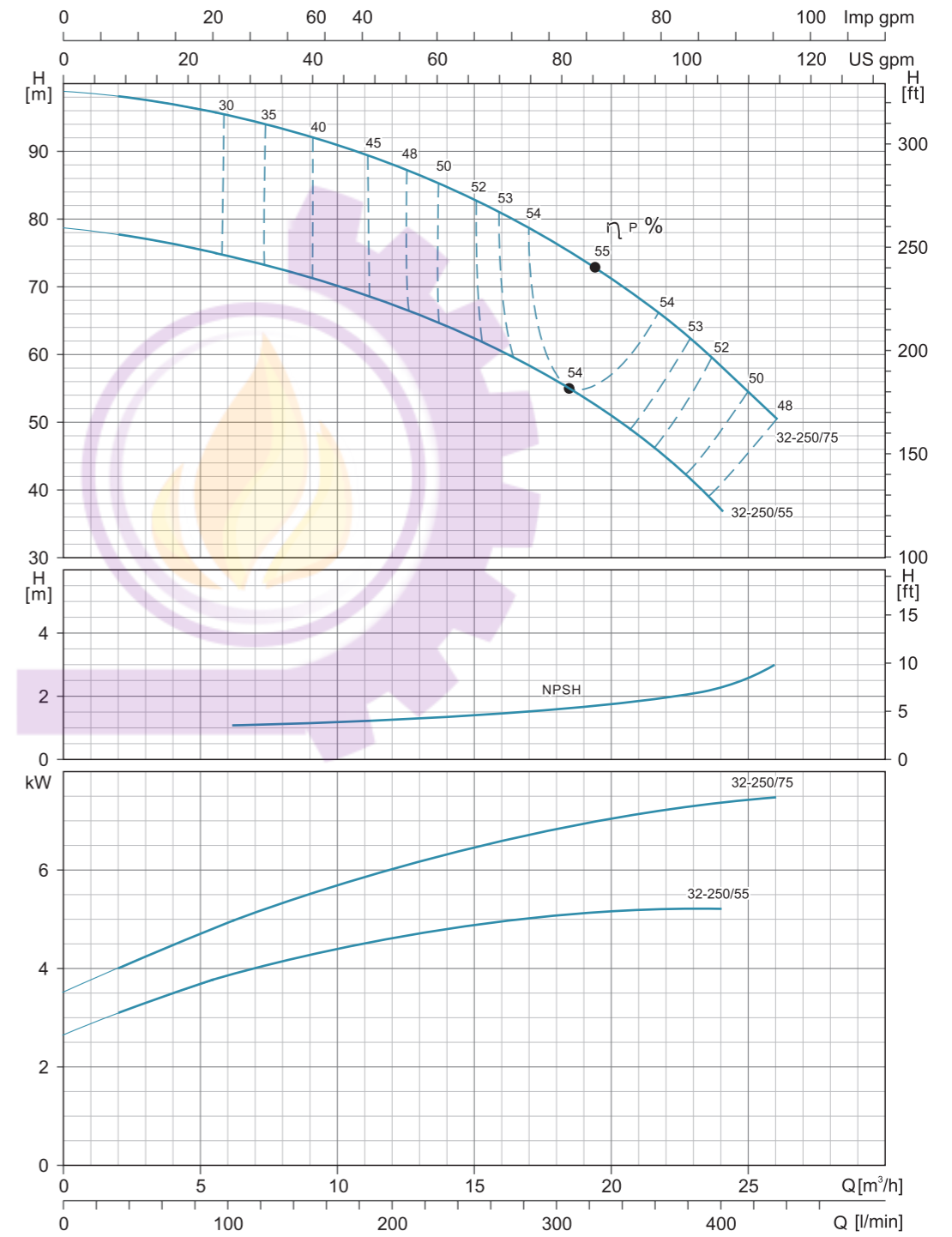

Hydraulic Performance Curves

XST40-125	~2900rpm	ISO 9906 Annex A
-----------	----------	------------------

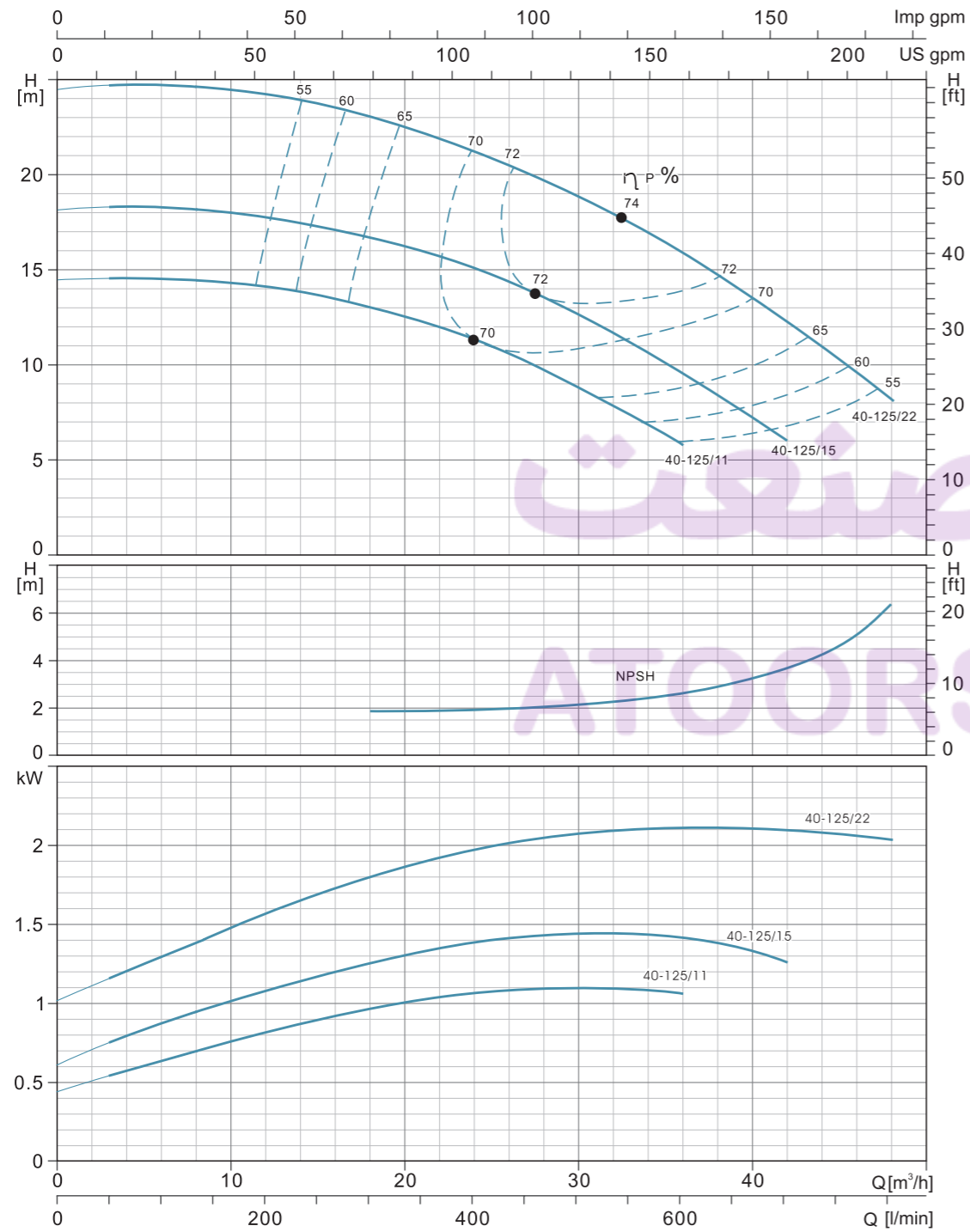

Hydraulic Performance Curves

XST40-160	~2900rpm	ISO 9906 Annex A
-----------	----------	------------------

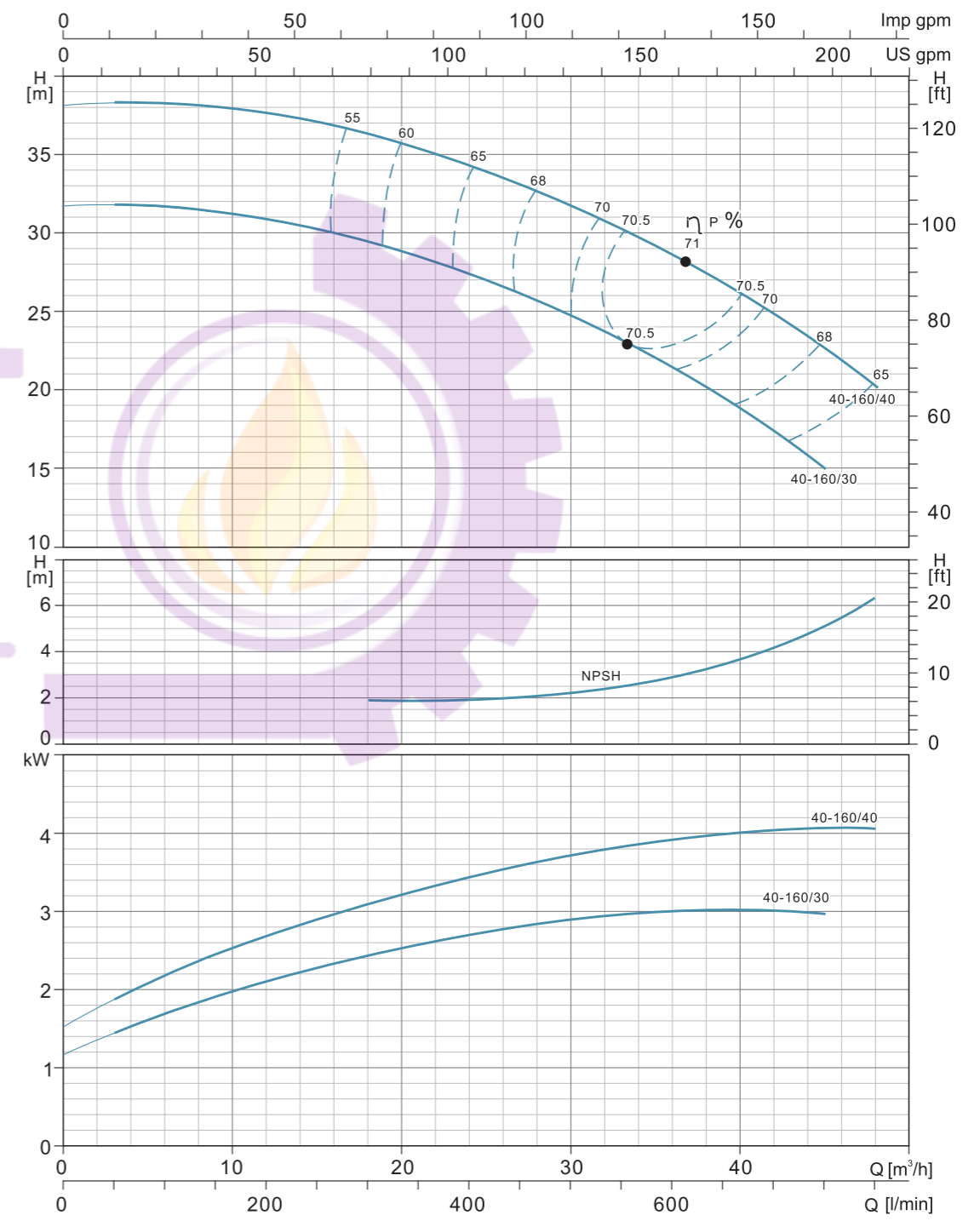

Hydraulic Performance Curves

XST40-200	~2900rpm	ISO 9906 Annex A
------------------	-----------------	-------------------------

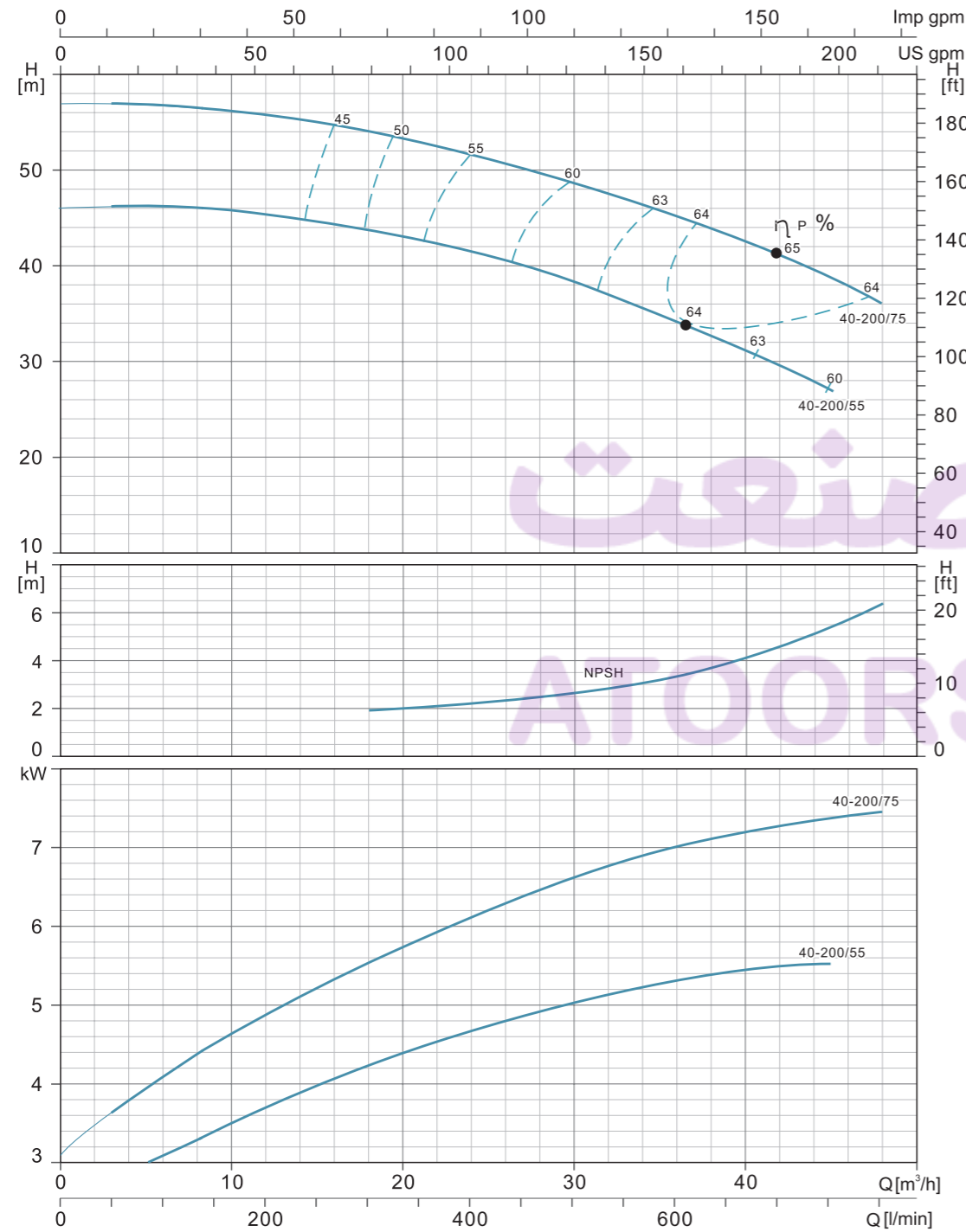

Hydraulic Performance Curves

XST40-250	~2900rpm	ISO 9906 Annex A
------------------	-----------------	-------------------------

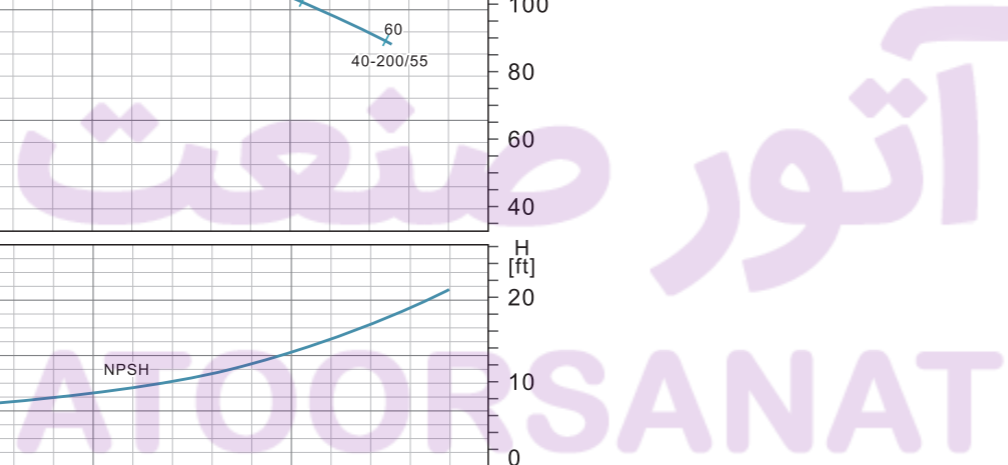
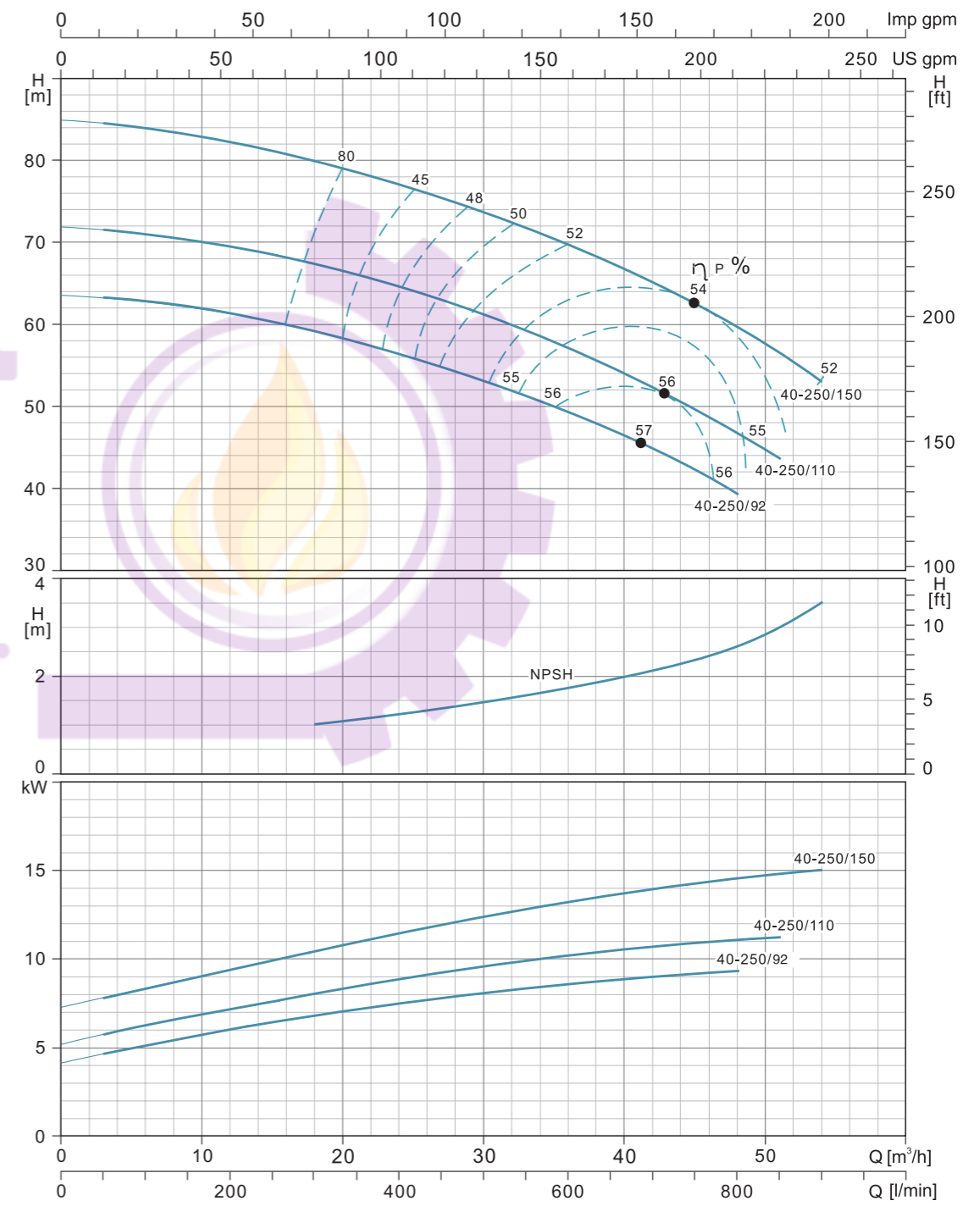

Hydraulic Performance Curves

XST50-125	~2900rpm	ISO 9906 Annex A
------------------	-----------------	-------------------------

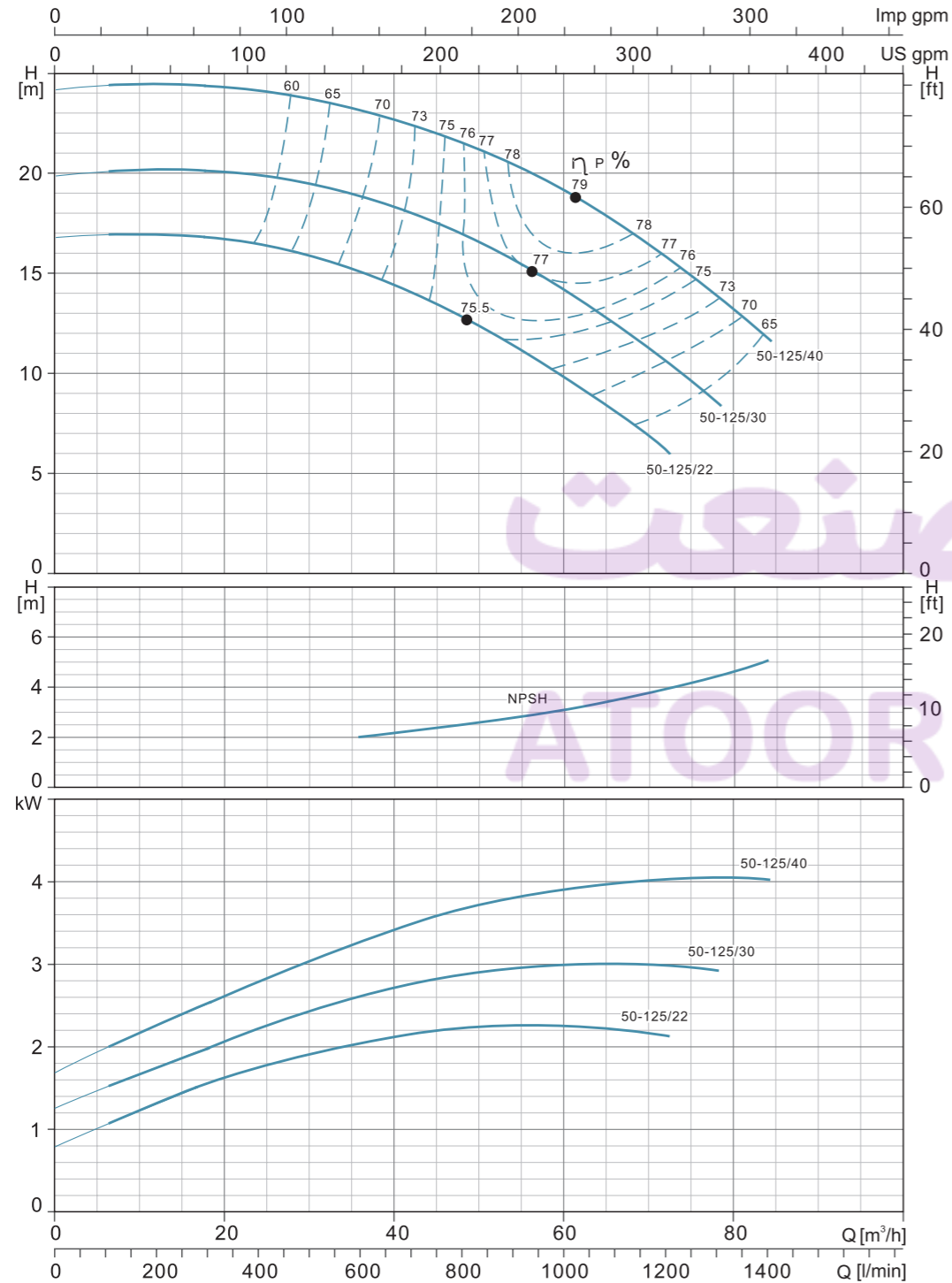

Hydraulic Performance Curves

XST50-160	~2900rpm	ISO 9906 Annex A
------------------	-----------------	-------------------------

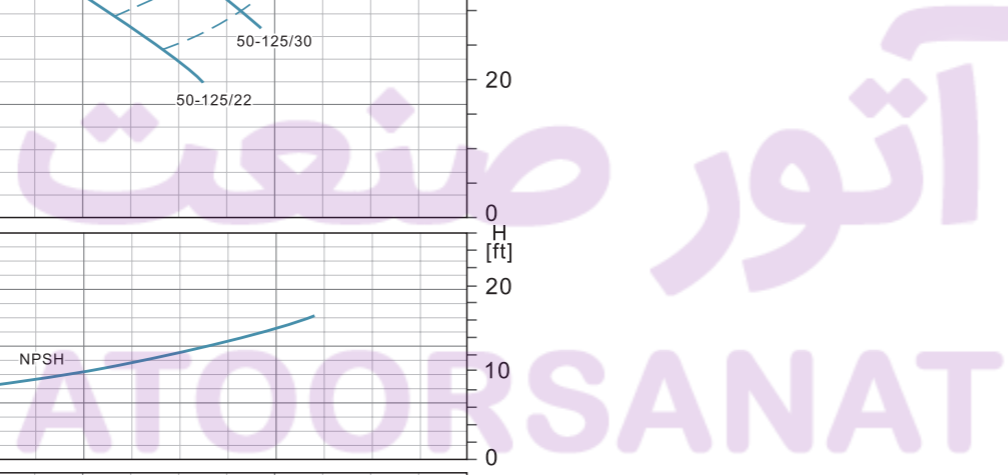
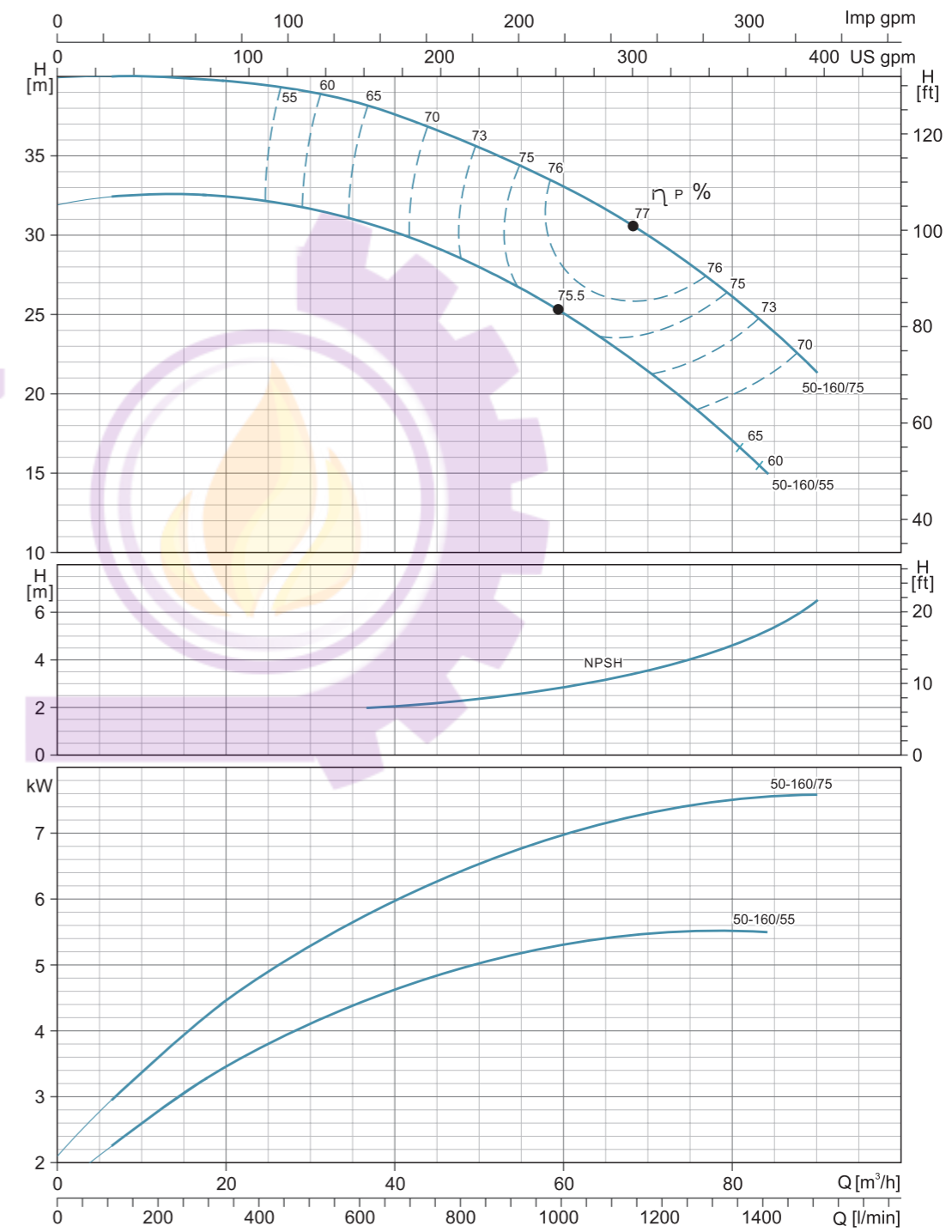

Hydraulic Performance Curves

XST50-200	~2900rpm	ISO 9906 Annex A
-----------	----------	------------------

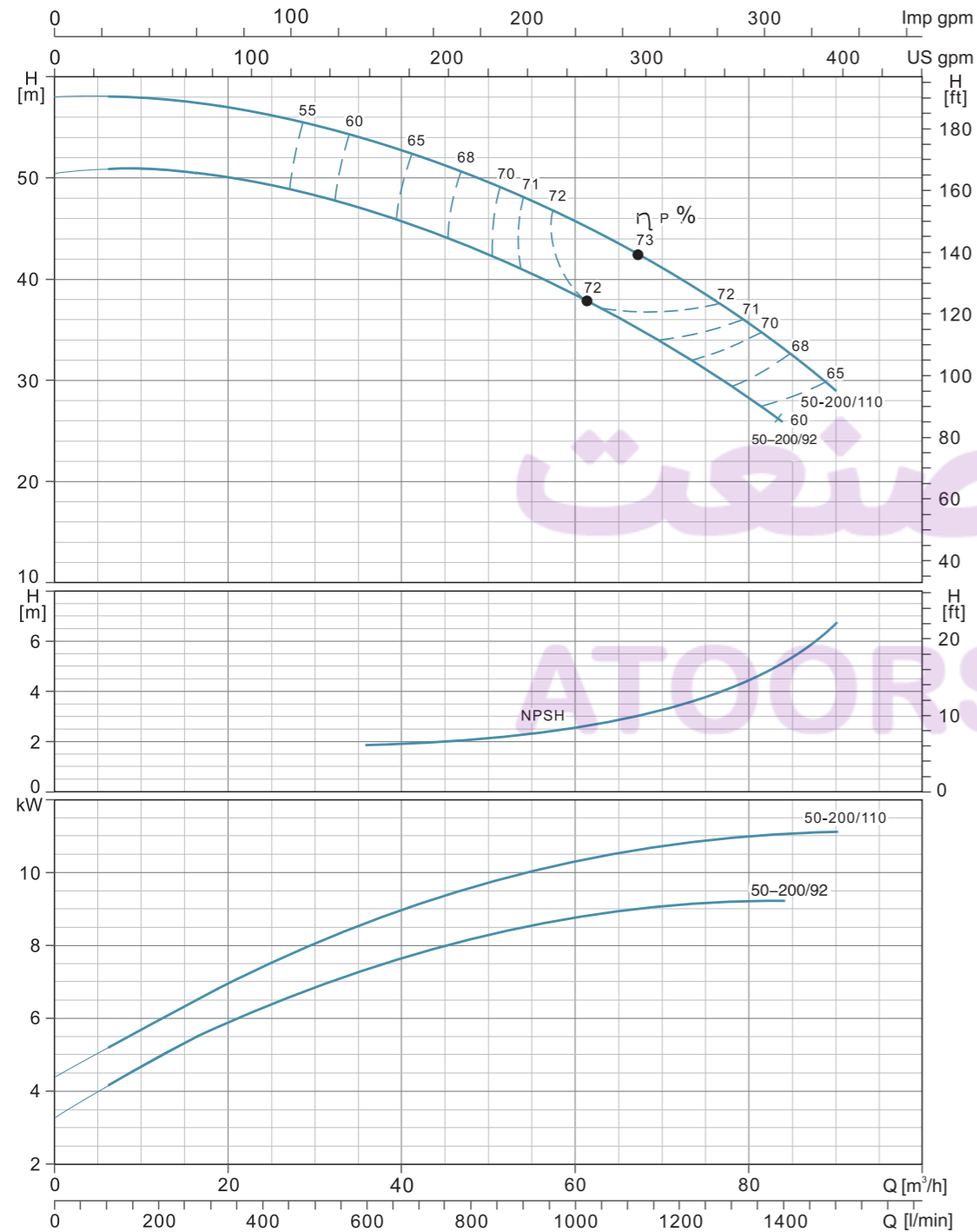

Hydraulic Performance Curves

XST50-250	~2900rpm	ISO 9906 Annex A
-----------	----------	------------------

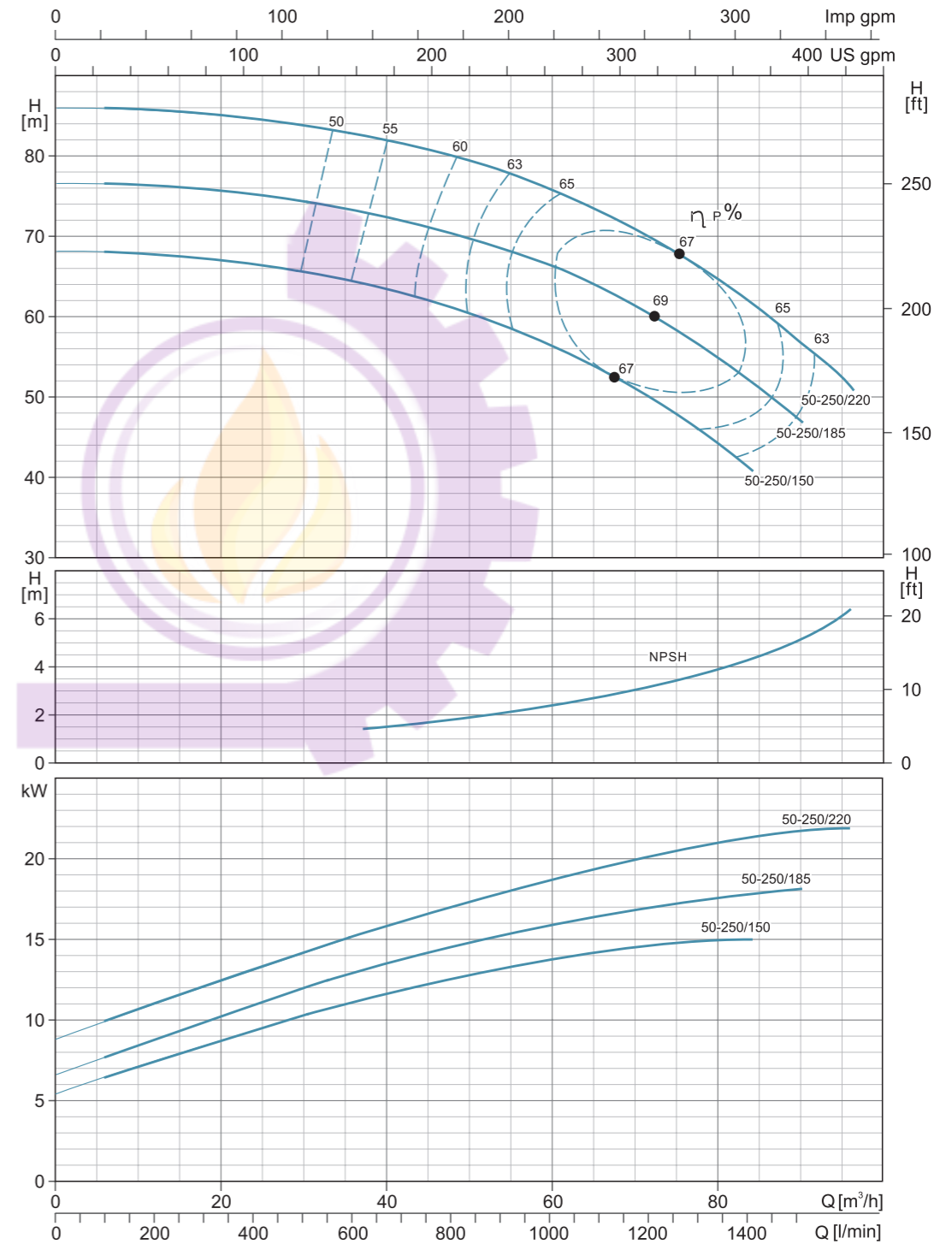

آتور صنعت
ATOORSANAT

Hydraulic Performance Curves

XST65-125	~2900rpm	ISO 9906 Annex A
------------------	-----------------	-------------------------

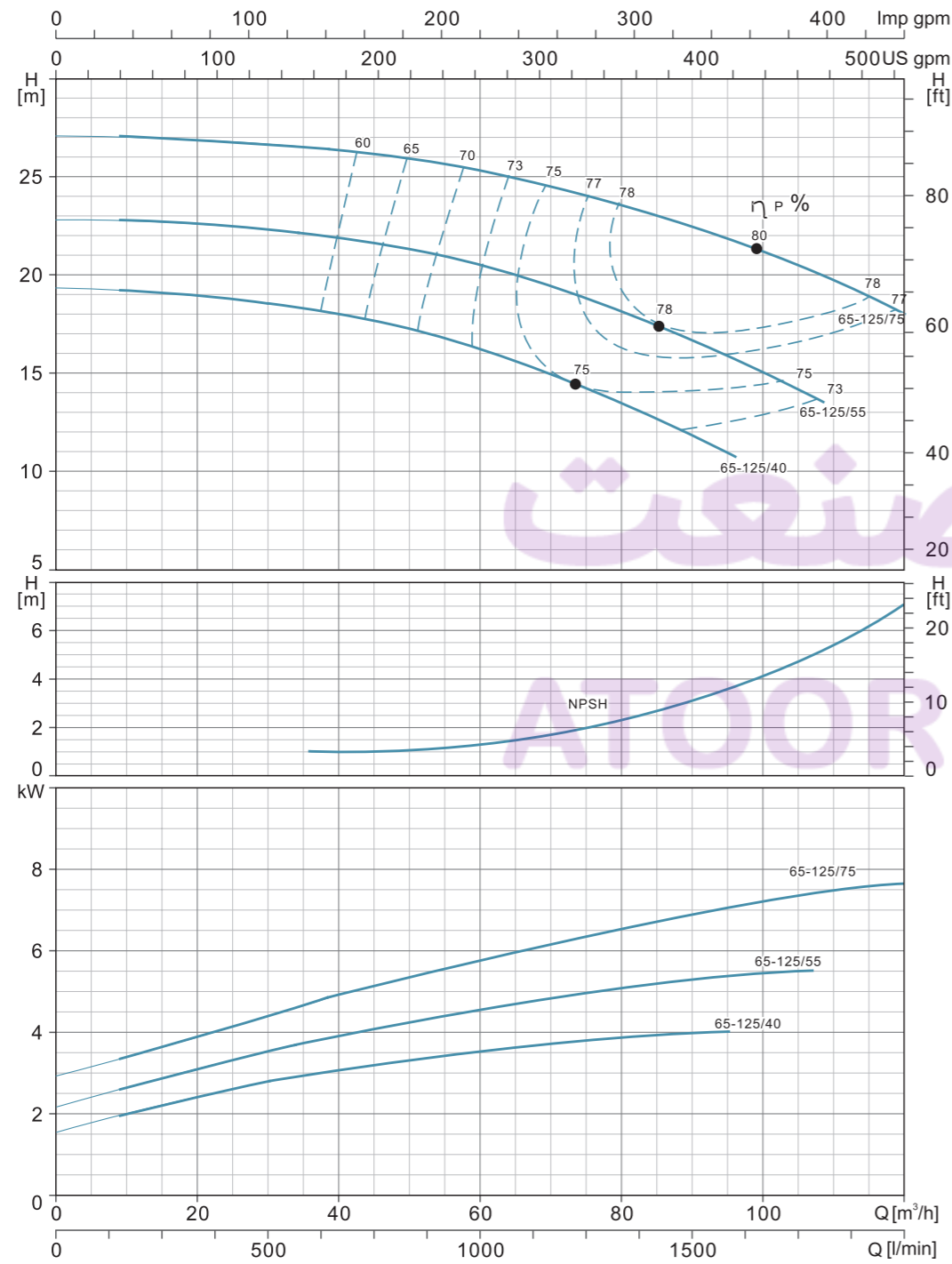

Hydraulic Performance Curves

XST65-160	~2900rpm	ISO 9906 Annex A
------------------	-----------------	-------------------------

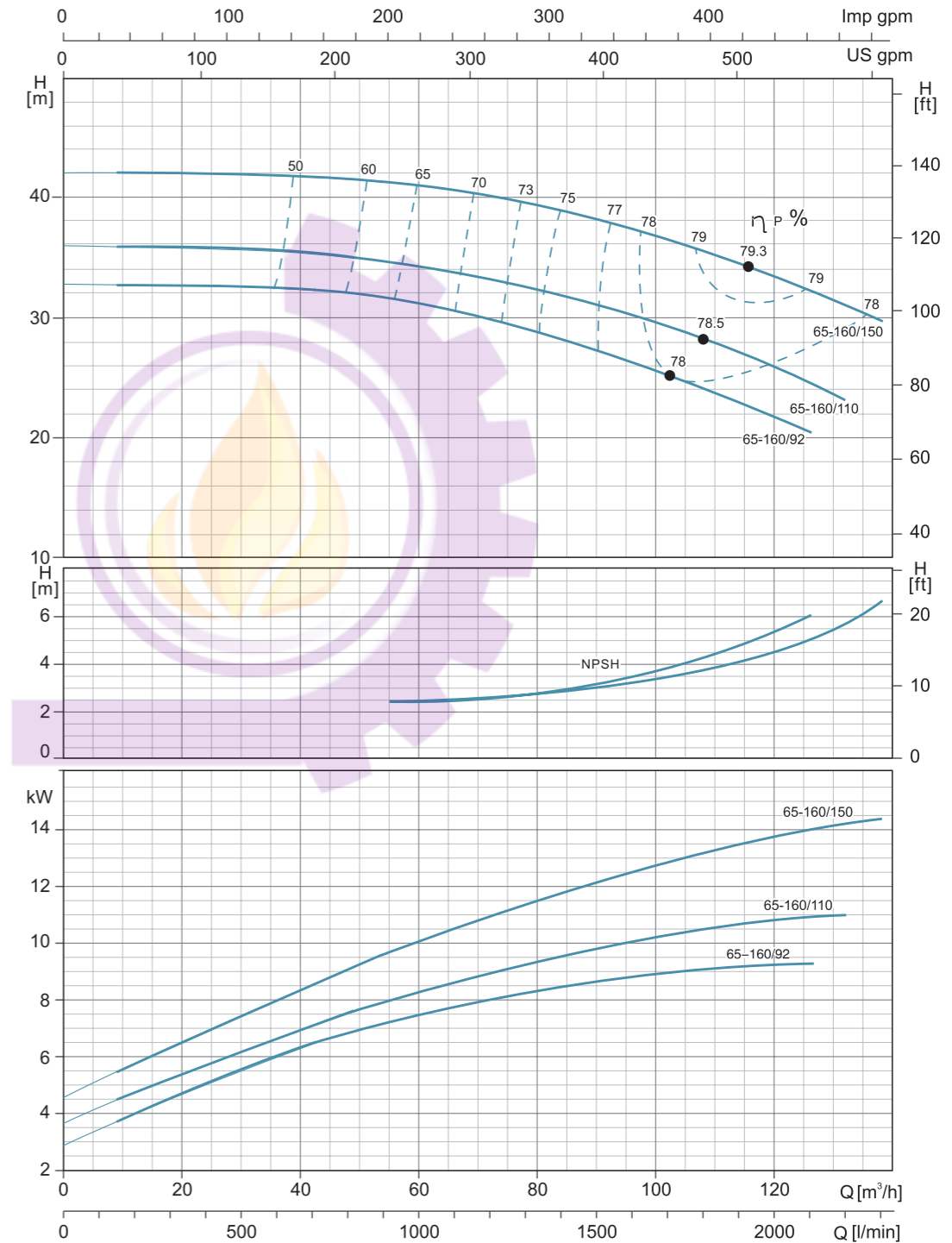

Hydraulic Performance Curves

XST65-200	~2900rpm	ISO 9906 Annex A
-----------	----------	------------------

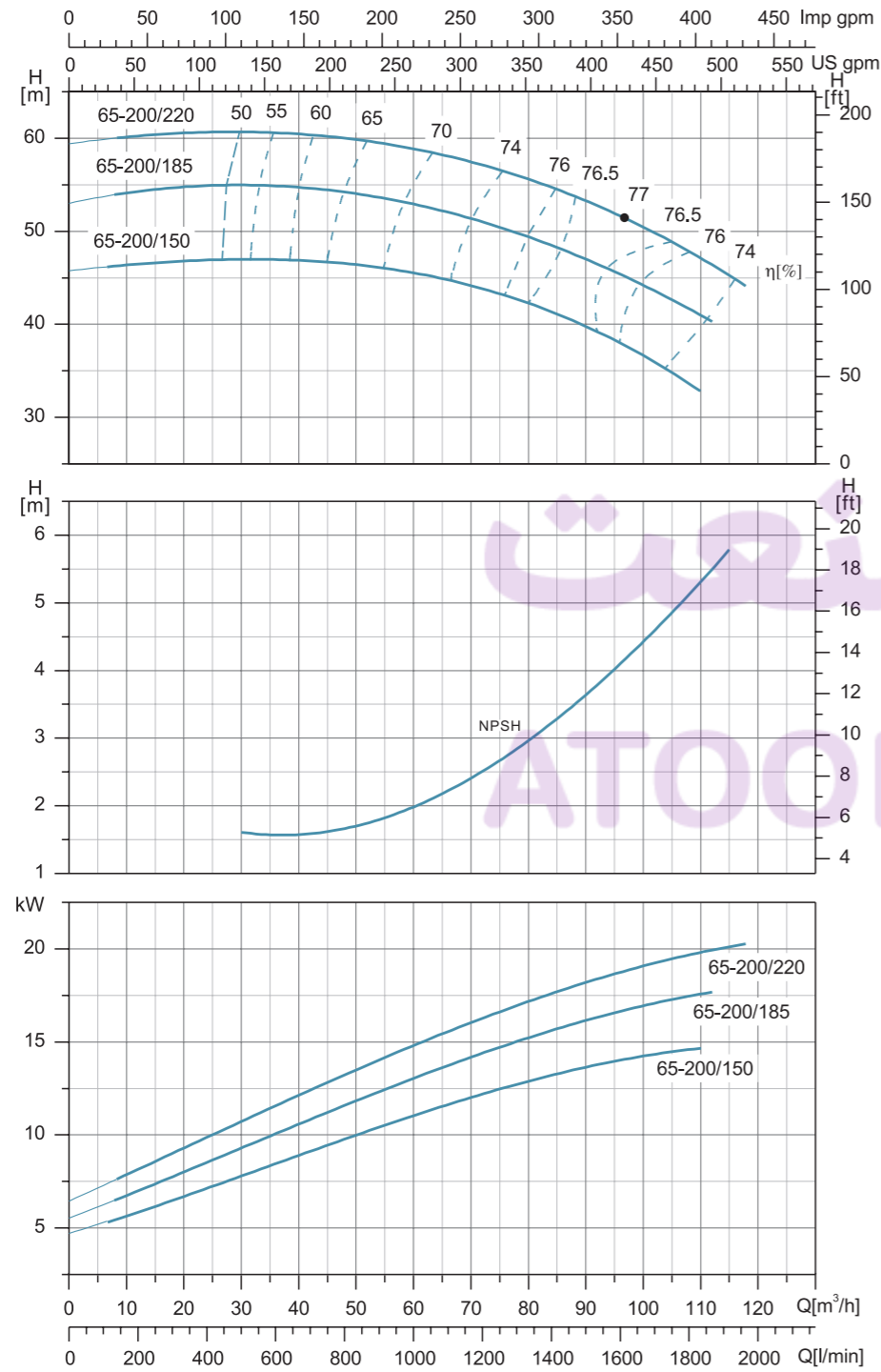

Hydraulic Performance Curves

XST65-200I	~2900rpm	ISO 9906 Annex A
------------	----------	------------------

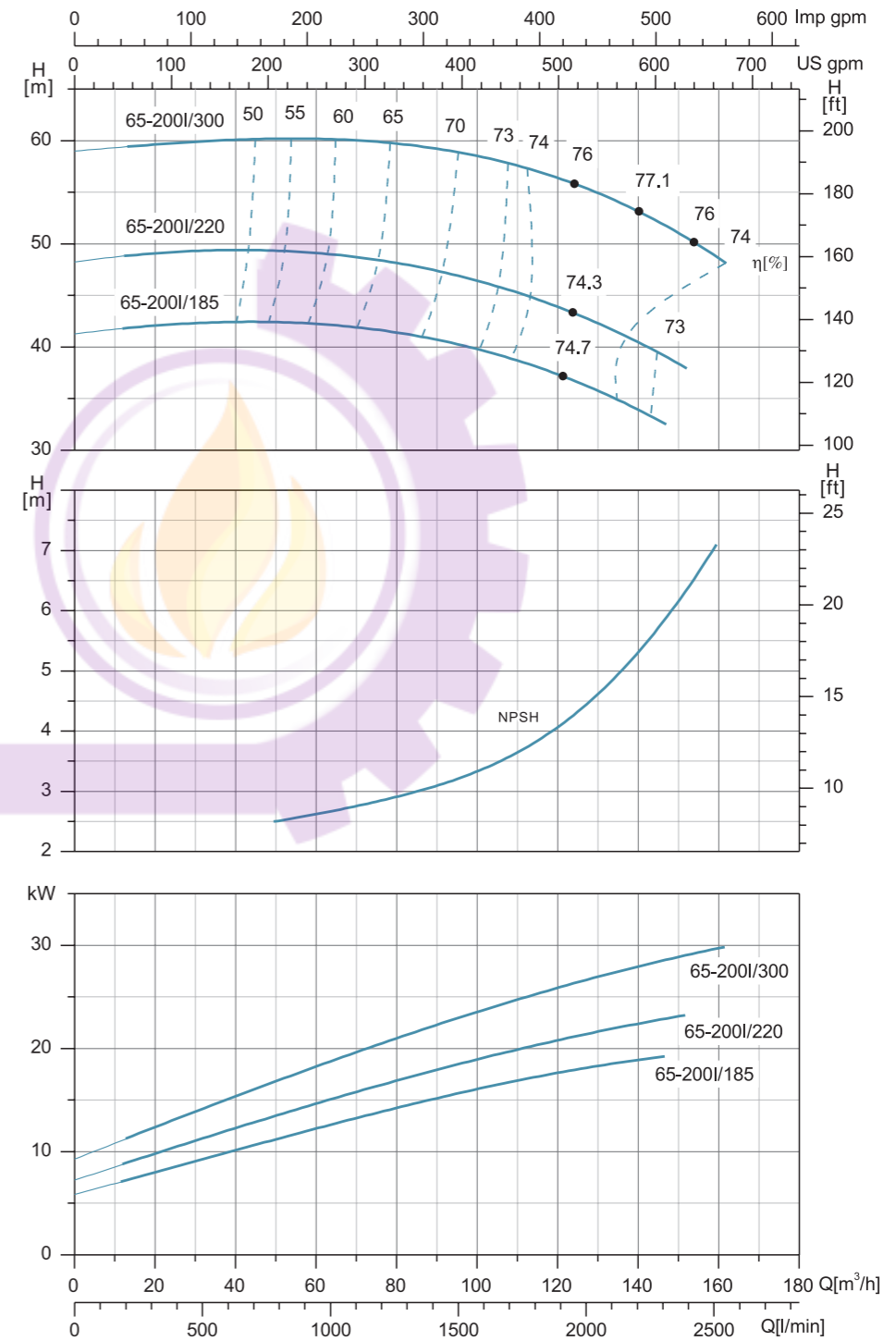

آتور صنعت
ATOORSANAT

Hydraulic Performance Curves

XST65-250	~2900rpm	ISO 9906 Annex A
-----------	----------	------------------

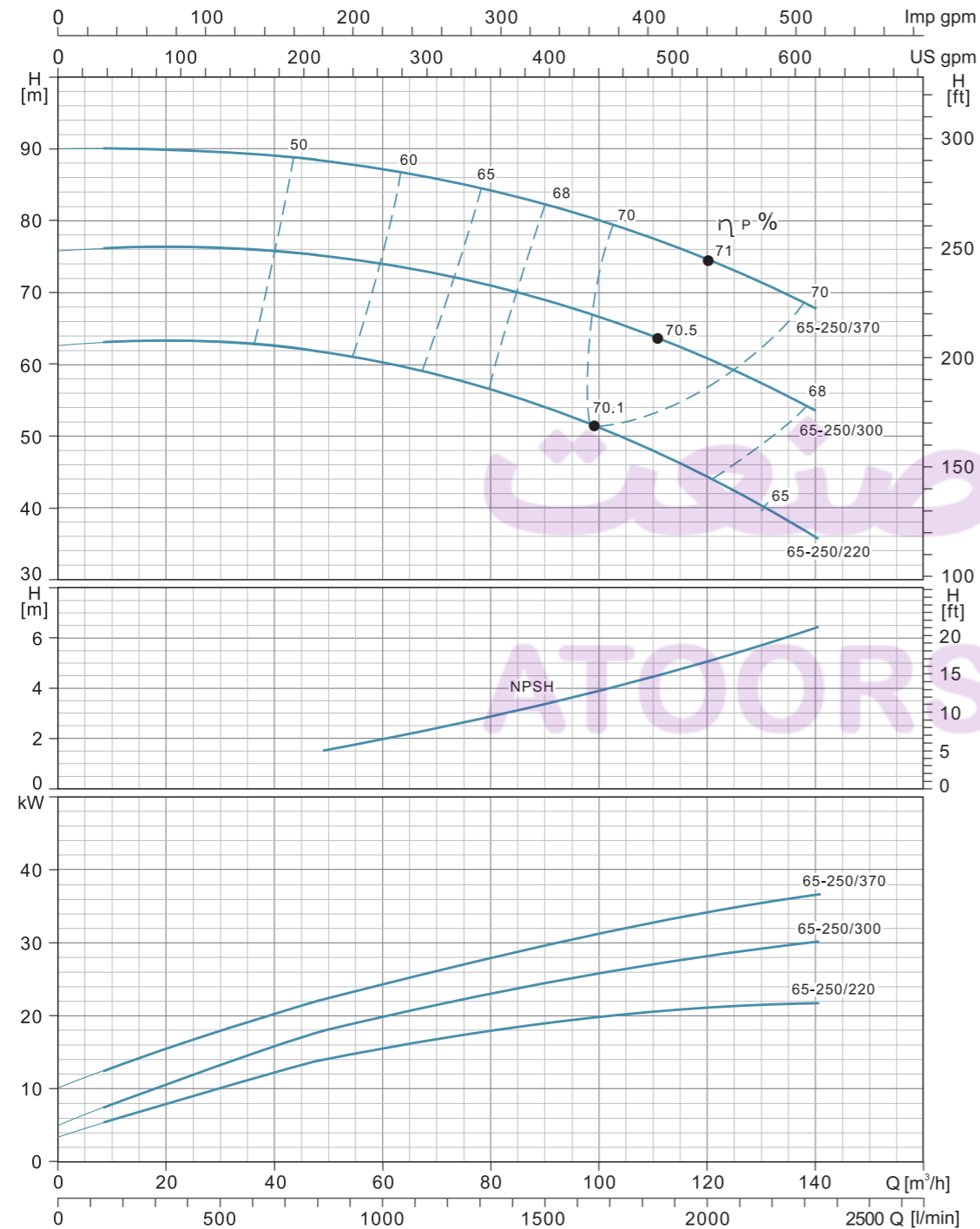

Hydraulic Performance Curves

XST80-160	~2900rpm	ISO 9906 Annex A
-----------	----------	------------------

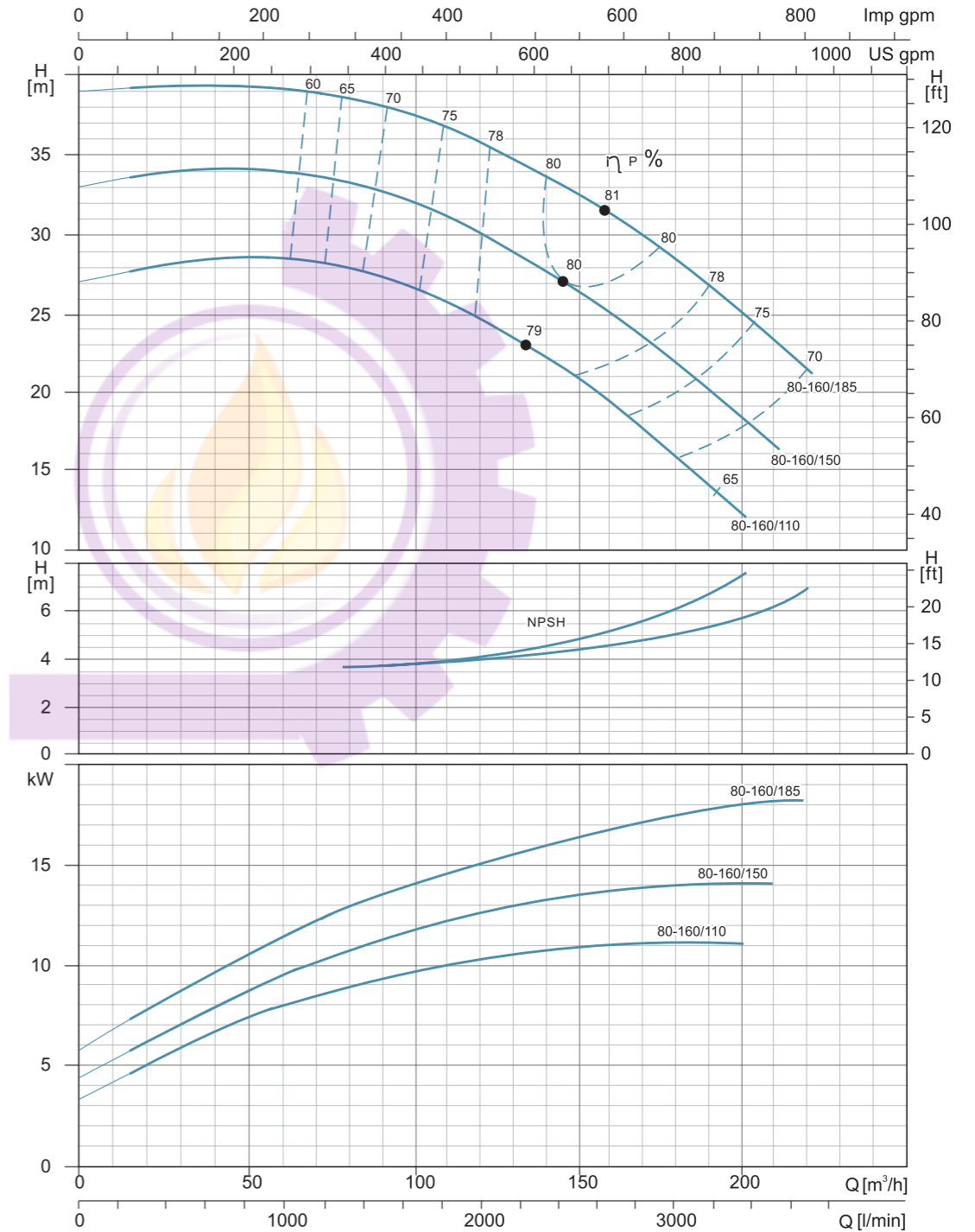

Hydraulic Performance Curves

XST80-200	~2900rpm	ISO 9906 Annex A
-----------	----------	------------------

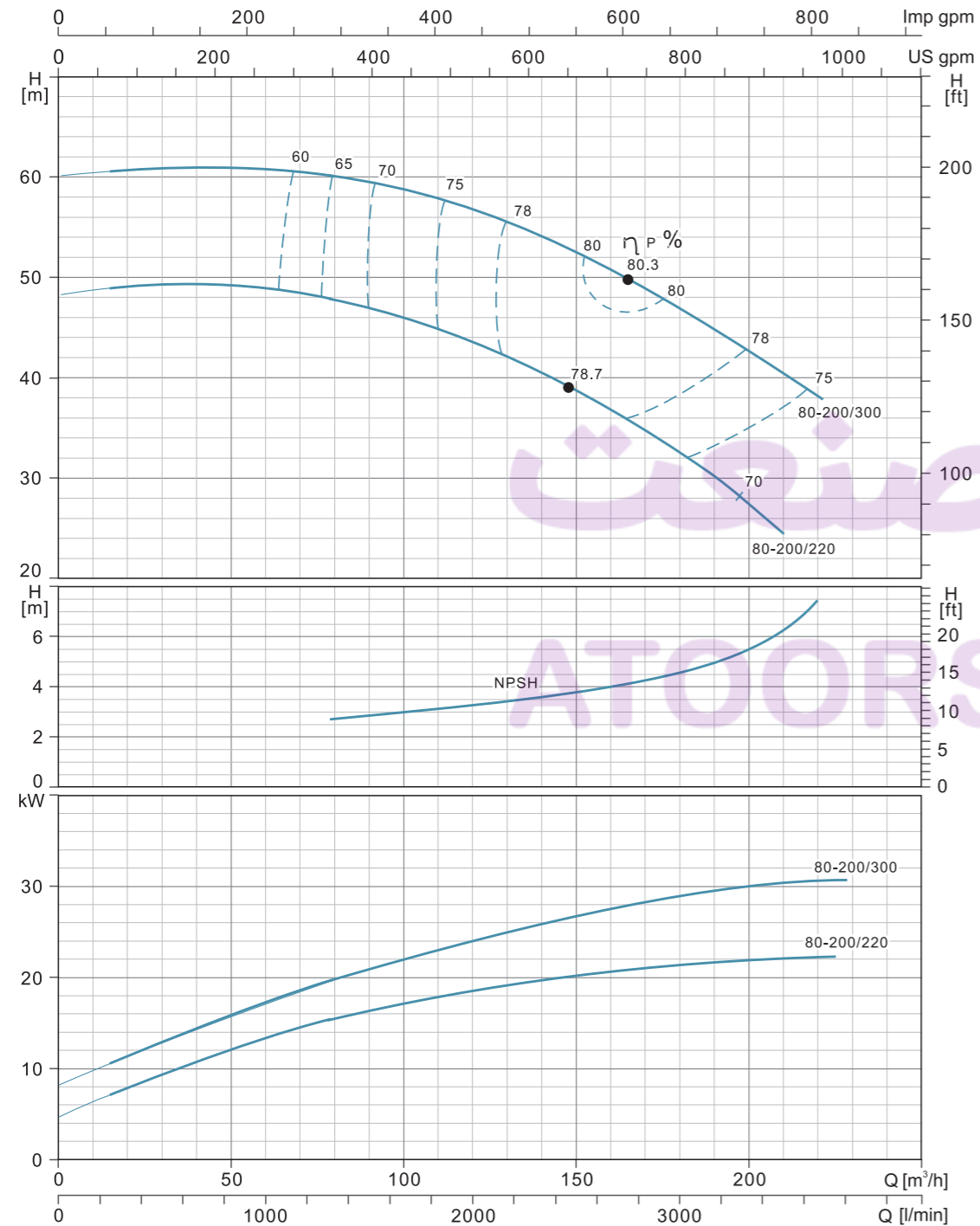

Hydraulic Performance Curves

XST80-250	~2900rpm	ISO 9906 Annex A
-----------	----------	------------------

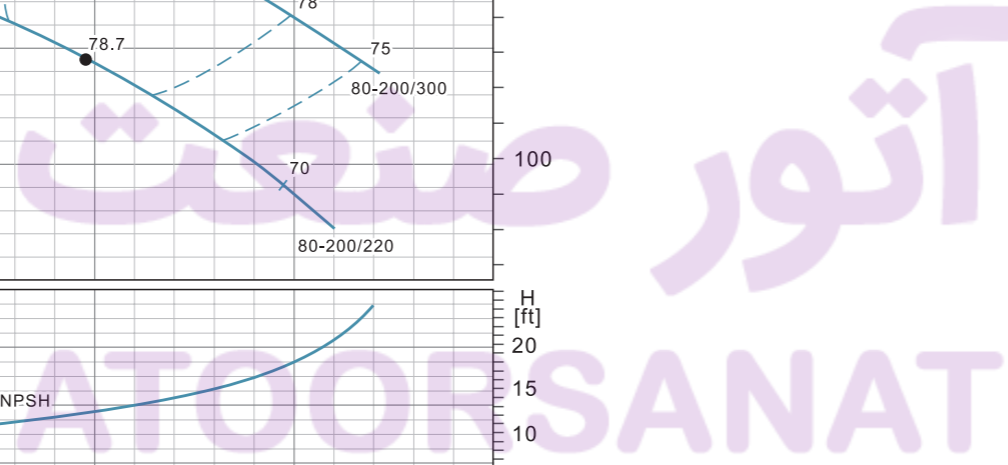
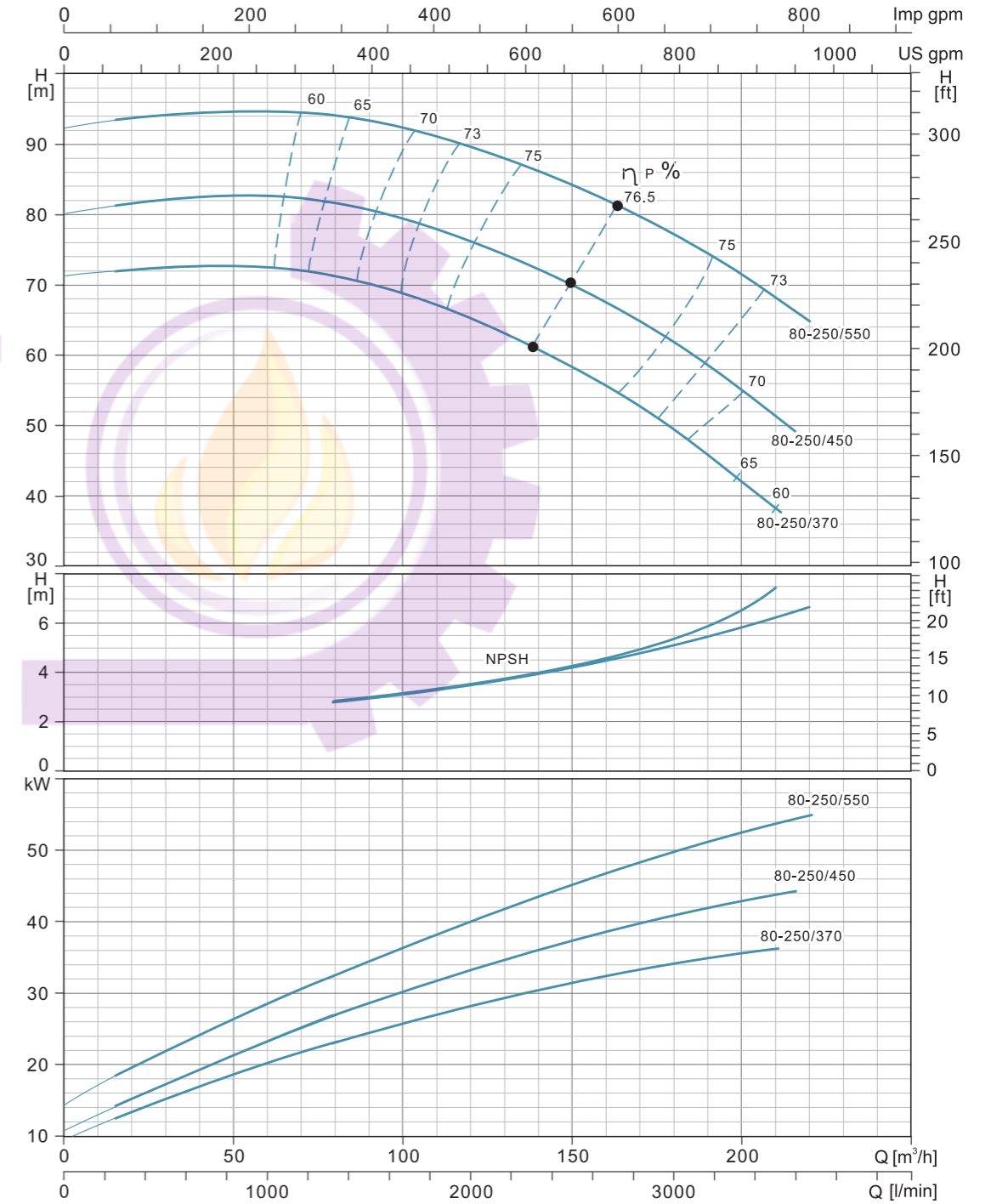

Flange Dimensions

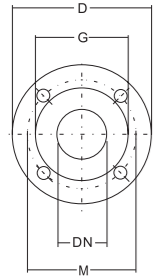

PN16 FLANGES

DN	D	M	G	HOLES N°	∅	MAX. THICKNESS
32	140	100	78	4	18	18
40	150	110	88	4	18	18
50	165	125	102	4	18	20
65	185	145	122	4	18	20

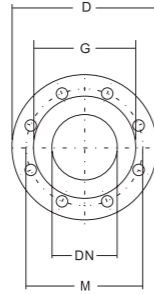

PN16 FLANGES

DN	D	M	G	HOLES N°	∅	MAX. THICKNESS
80	200	160	138	8	18	22
100	220	180	158	8	18	22

Installation Sketch

up to 7.5 kW included

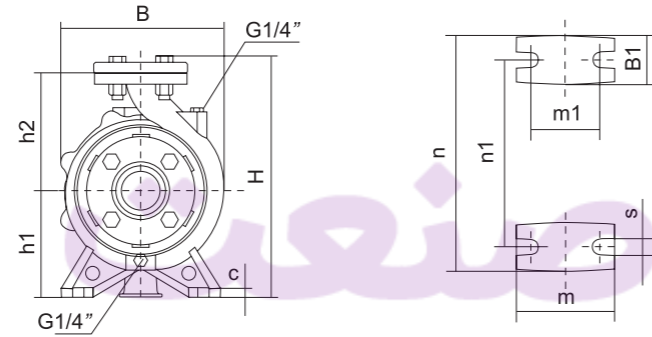
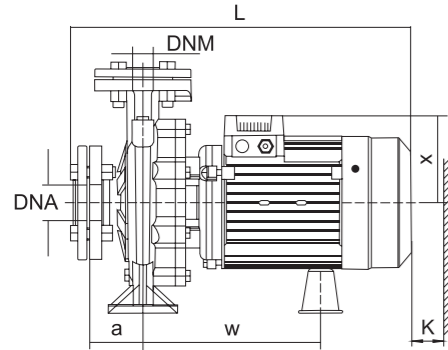

PUMP TYPE	DNM	DNA	a	h2	w	x	B1	c	h1	m	m1	n	n1	s	B	H	L	K																
32-125/7	32	50	80	223	113	140	48	12	112	100	70	190	140	17	192	281	427	85																
32-125/11																																		
32-160/15																																		
32-160/22																																		
32-160/30																																		
32-200/30																																		
32-200/40																																		
32-250/55																																		
32-250/75																																		
40-125/11																			40	65	80	255	127	140	45	12	132	100	70	210	160	218	282	489
40-125/15																																		
40-125/22																																		
40-160/30																																		
40-160/40																																		
40-200/55																																		
40-200/75																																		
50-125/22	50	65	100	262	127	160	50	12	132	100	70	240	190	243	322	518	110																	
50-125/30																																		
50-125/40																																		
50-160/55																																		
50-160/75																																		
65-125/40																		65	80	100	265	180	180	68	14	160	125	95	280	212	283	372	564	594
65-125/55																																		
65-125/75																																		

Installation Sketch

From 7.5 kW

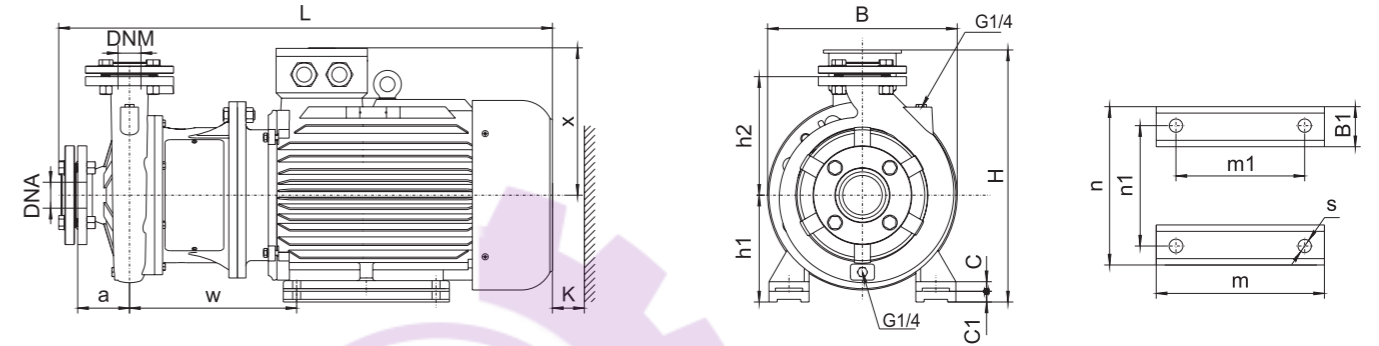

PUMP TYPE	DNM	DNA	a	h2	w	x	B1	C	C1	h1	m	m1	n	n1	s	B	H	L	K																																						
40-250/92	40	65	100	310	260	225	65	20	20	180	260	210	320	254	14.5	350	440	845	110																																						
40-250/110																																																									
40-250/150																																																									
50-200/992																				50	65	100	310	260	225	65	20	20	160	260	210	320	254	14.5	350	420	845	120																			
50-200/110																																																									
50-250/150																																																									
50-250/185																																																									
50-250/220																																																									
65-160/92																																							65	80	100	310	260	225	70	25	-	180	304	254	355	279	14.5	350	440	895	110
65-160/110																																																									
65-160/150																																																									
65-200/150																																																									
65-200/185																																																									
65-200/220																																																									
65-200/185																																																									
65-200/220																																																									
65-200/185																																																									
65-200/220																																																									
65-200/300																																																									
65-250/220	65	80	100	323	275	225	70	22	-	180	311	241	355	279	14.5	355	455	925	125																																						
65-200/220																																																									
65-200/185																																																									
65-200/220																																																									
65-200/300																																																									
65-250/220																																																									
65-250/300																																																									
65-250/370																																																									
80/160-110																				80	100	125	315	260	225	65	20	-	160	260	210	320	254	14.5	350	420	870	130																			
80-160/150																																																									
80-160/185																																																									
80-200/220																																																									
80-200/300																																																									
80-250/370																																																									
80-150/450	80	100	125	381	330	280	75	28	-	225	404	311	435	356	18.5	450	555	1098	120																																						
80-250/550																																																									
80-150/450																																																									
80-250/370																																																									
80-250/550																																																									