



CATALOGUE 2016

WATER TREATMENT DIVISION
SWIMMING POOL DIVISION
INDUSTRIAL DIVISION



ISO 14001
BUREAU VERITAS
Certification



ISO 9001
BUREAU VERITAS
Certification



SA8000
BUREAU VERITAS
Certification



WATER TREATMENT DIVISION



ATHENASERIES
POMPE DOSATRICI ELETTROMAGNETICHE
ELECTROMAGNETIC DOSING PUMPS

- 3
- 4
- 5
- 6
- 7
- 8



GEASERIES
POMPE DOSATRICI ELETTROMAGNETICHE a frequenza e corsa regolabili
ELECTROMAGNETIC DOSING PUMPS adjustable strokes and frequency

- 9
- 10
- 11
- 12
- 13



HYDRASERIES
POMPE DOSATRICI ELETTROMAGNETICHE
ELECTROMAGNETIC DOSING PUMPS

- 4
- 5
- 6



OLIMPIASERIES
POMPE DOSATRICI ELETTROMAGNETICHE
ELECTROMAGNETIC DOSING PUMPS

- 7



NIKESERIES
POMPE PERISTALTICHE
PERISTALTIC PUMPS

- 1



SYSTEMSSERIES
SISTEMI DI DOSAGGIO PROPORZIONALI E TEMPORIZZATI
PROPORTIONAL AND TEMPORISED DOSING SYSTEMS

- 2

WATER TREATMENT DIVISION



TAURUSSERIES
POMPE DOSATRICI ELETTROMECCANICHE
ELECTROMECHANIC DOSING PUMPS

- 4
- 5



TAURUS.INV SERIES
POMPE DOSATRICI ELETTROMECCANICHE INVERTER INCORPORATO
ELECTROMECHANIC DOSING PUMPS WITH ASSEMBLED INVERTER

- 6



WATER TREATMENT DIVISION



TAURUS.12 VDC SERIES

POMPE DOSATRICI ELETTROMECCANICHE 12 VDC
12 VDC ELECTROMECHANIC DOSING PUMPS

○ 3 2



DOSING.UNIT SERIES

○ 3 3

INSTRUMENT PRODUCTS



NEXUS.1000/2000 SERIES

STRUMENTI DI MISURA E CONTROLLO
MEASUREMENT AND CONTROL INSTRUMENTS

○ 3 8
○ 3 9
○ 4 0
○ 4 1



NEXUS.4000 SERIES

STRUMENTI PER ANALISI DA PROCESSO
INSTRUMENTS FOR PROCESS ANALYSIS

○ 4 2
○ 4 3



NEXUS.5000 SERIES

STRUMENTI PER ANALISI DA PROCESSO
INSTRUMENTS FOR PROCESS ANALYSIS

○ 4 4
○ 4 5



NEXUS.6000/6500 SERIES

STRUMENTI INDUSTRIALI
INDUSTRIAL INSTRUMENTS

○ 4 6
○ 4 7
○ 4 8
○ 4 9



NEXUS.7000 SERIES

STRUMENTO MULTIPARAMETRICO
MULTIPARAMETRIC INSTRUMENT

○ 5 0
○ 5 1



DI.MPO SERIES

MISURATORI DI PORTATA A INDUZIONE MAGNETICA
MAGNETIC INDUCTION FLOW METER

○ 5 2
○ 5 3
○ 5 4
○ 5 5



DI.MPU SERIES

MISURATORI DI PORTATA/LIVELLO ULTRASUONI
FLOW/LEVEL ULTRASONIC MEASUREMENT

○ 5 6
○ 5 7
○ 5 8
○ 5 9



WATER TREATMENT DIVISION



WMSERIES

CONTATORI FILETTATI O FLANGIATI PER ACQUA
THREADED OR FLANGED WATER METERS

6 0
6 1



MXSERIES

AGITATORI ELETTRICI
ELECTRICAL MIXERS

6 2
6 3
6 4



LANCE DI ASPIRAZIONE, SERBATOI, PIASTRE DI SUPPORTO
SUCTION LANCES, TANKS, RE-INFORCED TANKS

6 5



READING & MEASUREMENT

SENSORI, SONDE, CELLE
SENSORS, PROBES, CELLS

6 6
6 7
6 8
6 9
7 0
7 1
7 2
7 3
7 4
7 5
7 6

آتور صنعت
ATOORSANAT

ELECTROMAGNETIC PRODUCTS

SWIMMING POOL DIVISION



ATHENA.PR SERIES

POMPA DOSATRICE ELETTROMAGNETICA CON STRUMENTO pH/Redox
ELECTROMAGNETIC DOSING PUMP WITH pH/Redox INSTRUMENT

7 7



OLIMPIA SERIES

POMPA DOSATRICE ELETTROMAGNETICA
ELECTROMAGNETIC DOSING PUMP

7 8

SWIMMING POOL DIVISION

PERISTALTIC PRODUCTS



NIKE.TEMP SERIES

POMPA PERISTALTICA TEMPORIZZATA
TEMPORISED PERISTALTIC PUMP

7 9



BIO.TEMP SERIES
SISTEMA DI DOSAGGIO TEMPORIZZATO
TEMPORISED DOSING SYSTEM

7 9

SWIMMING POOL DIVISION



ELITE SERIES
SISTEMI DIGITALI PER IL CONTROLLO DI pH/Redox
DIGITAL SYSTEMS FOR pH/Redox CONTROL

8 0



ELITE.PRC SERIES
SISTEMI DIGITALI PER IL CONTROLLO DI CL e pH/Redox
DIGITAL SYSTEMS FOR Cl and pH/Redox CONTROL

8 1



ELITE.PLUS SERIES
SISTEMI DIGITALI PER IL CONTROLLO DI pH/Redox e FLOCCULANTE
DIGITAL SYSTEMS FOR pH/Redox and FLOCCULANT CONTROL

8 2
8 3
8 4



ELITE.SP PR SERIES
SISTEMI DI DOSAGGIO PROPORZIONALE PER IL CONTROLLO DI pH/Redox
PROPORTIONAL DOSING SYSTEMS FOR pH/Redox CONTROL

8 4



HELIOS SERIES
SISTEMI AUTOMATICI DI CONTROLLO pH/Redox, CLORO
pH/Redox, CHLORINE AUTOMATIC CONTROL SYSTEMS

8 5



HELIOS SERIES
SISTEMI AUTOMATICI DI CONTROLLO pH, CLORO POTENZIOSTATICO, TEMP
pH, POTENTIOSTATIC CHLORINE, TEMP AUTOMATIC CONTROL SYSTEMS

8 6
8 7



STERIL SERIES
STERILIZZATORE A SALE
SALT STERILIZER

8 8



STERIL.PANEL SERIES

8 9



Chlorine.MeterSERIES
COLORIMETRO INDUSTRIALE E MULTIFUNZIONE
MULTIFUNCTION INDUSTRIAL CHLORINE METER

9 0



PhotometersSERIES

9 1

INDUSTRIALDIVISION

ACCESSORY**PRODUCTS**



NEXUS.2000SERIES
STRUMENTI DI MISURA E CONTROLLO
MEASURING AND CONTROL INSTRUMENTS

9 2
9 3



SYSTEMSSERIES
SISTEMI DI DOSAGGIO PROPORZIONALI E TEMPORIZZATI
PROPORTIONAL AND TEMPORISED DOSING SYSTEMS

9 4



ELITE.SP PRSERIES
SISTEMI DI DOSAGGIO PROPORZIONALE PER IL CONTROLLO DI pH/Redox
PROPORTIONAL DOSING SYSTEMS FOR pH/Redox CONTROL

9 5



ATHENASERIES
POMPE DOSATRICI ELETTROMAGNETICHE
ELECTROMAGNETIC DOSING PUMPS

9 6
9 7
9 8

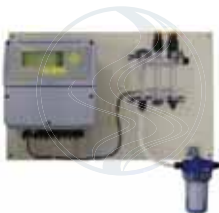

HELIOSERIES
SISTEMI DI CONTROLLO pH/Redox, Conducibilità
Conductivity, pH/Redox CONTROL SYSTEMS

9 9



MIXSERIES

PREPARATORE AUTOMATICO DI SOLUZIONI POLIELETTROLITICHE
AUTOMATIC CONTINUOUS FLOW POLYELECTROLYTE SOLUTION PREPARER

1 0 0
1 0 1

1 0 2
1 0 3
1 0 4
1 0 5
1 0 6
1 0 7
1 0 8
1 0 9
1 1 0
1 1 1
1 1 2
1 1 3
1 1 4
1 1 5
1 1 6
1 1 7
1 1 8
1 1 9
1 2 0

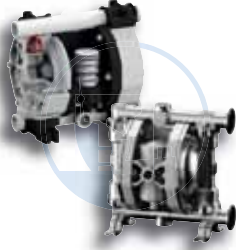

GEMINISERIES

POMPE PNEUMATICHE A DOPPIA MEMBRANA
PNEUMATIC DOUBLE DIAPHRAGM PUMPS



1 2 1

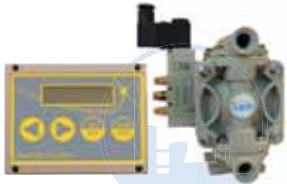

GEMINI CONTROLSERIES

آتور صنعت

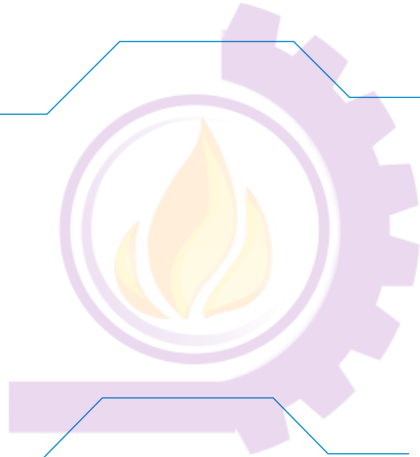

DI.SSERIES

STAZIONI DI DOSAGGIO INTEGRATE
INTEGRATED DOSING STATION

1 2 2
1 2 3

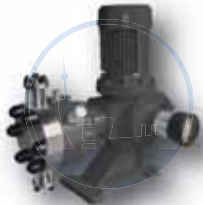

LIBRASERIES

POMPE A SINGOLA MEMBRANA IDRAULICA
HYDRAULIC SINGLE DIAPHRAGM METERING PUMP

1 2 4
1 2 5

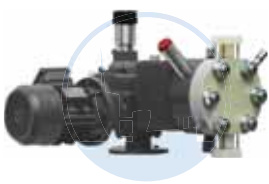

POWERSERIES

POMPE A DOPPIA MEMBRANA IDRAULICA
HYDRAULIC DOUBLE DIAPHRAGM METERING PUMP

1 2 6
1 2 7



WATER TREATMENT DIVISION

ATHENA SERIES

POMPE DOSATRICI ELETTROMAGNETICHE ELECTROMAGNETIC DOSING PUMPS

CARATTERISTICHE GENERALI GENERAL FEATURES



- **TESTA IN PVDF** adatta per prodotti chimici usati nelle applicazioni industriali, nel trattamento acqua e nella potabilizzazione
- **SFERE IN CERAMICA** affidabilità del dosaggio e compatibilità chimica
- **DIAFRAMMA in PTFE** resistenza e compatibilità con tutti i prodotti chimici
- **DOSAGGIO COSTANTE** Alimentazione multi-tensione stabilizzata 100÷240 Vac 50/60 Hz con basso assorbimento
- **CONNESSIONE RAPIDA**
- **VALVOLA DI SPURGO MANUALE**
- **PROTEZIONE IP65**

- **PVDF PUMP HEAD** suitable for chemical used in the Industrial, Waste Water Treatment and Potable Water applications
- **CERAMIC BALL** full chemical compatibility
- **PTFE DIAPHRAGM** unique life expectancy and compatibility with most chemicals
- **STEADY DOSING** Stabilized Multi Power Supply 100÷240 Vac 50/60 Hz with reduced consumption
- **QUICK CONNECTIONS**
- **MANUAL PRIMING VALVE**
- **IP65 PROTECTION**

ANALOGIC VERSION



- **PORTATA REGOLABILE** con Manopola sul Pannello Frontale
- **POWER-ON e LED ALLARME DI LIVELLO**

- **ADJUSTABLE FLOW RATE** a knob on the Front Panel
- **POWER-ON and LEVEL ALARMS LED**

DIGITAL VERSION



- **DISPLAY LCD RETROILLUMINATO** a 2 Linee di 16 Caratteri
- **PROGRAMMAZIONE E FUNZIONAMENTO** in 5 Lingue Selezionabili
- Possibilità di impostare **PASSWORD DI SICUREZZA**
- Predisposizione per **SENSORE DI FLUSSO**
- **VISUALIZZAZIONE STATISTICHE DI FUNZIONAMENTO**
- **RELÉ DI RIPETIZIONE ALLARME**

- **LCD BACK-LIT DISPLAY** with 2 - 16 Digit Rows
- **PROGRAMMING AND WORKING** in 5 Selectable Languages
- **SECURE PASSWORD AVAILABLE**
- **FLOW SENSOR CONFIGURED**
- **FLASHING OF FUNCTIONING STATISTICS**
- **ALARM REPETITION RELAY**



POSSIBILITÀ DI PERSONALIZZAZIONE SU RICHIESTA
POSSIBILITY CUSTOMIZATION UPON REQUEST



CARATTERISTICHE TECNICHE TECHNICAL FEATURES

DATI RILEVATI CON ACQUA A TEMPERATURA AMBIENTE CON ALTEZZA ASPIRAZIONE 1,5 mt
ALL DATA HAS TO BE CONSIDERED AT AMBIENT TEMPERATURE WATER AND 1,5 mt SUCTION HEIGHT

ATHENA BASSA PORTATA LOW FLOW

PORTATE FLOW RATES	PRESSIONI PRESSURES	CC/IMP. CC/STROKE	CONNESSIONI CONNECTIONS	IMP./MIN STROKES/MIN.	ASSORBIMENTO CONSUPTION	PESO WEIGHT
0,4 l/h	20 bar	0,06	4x6 / 4x7	120	14 Watt	3 kg
0,8 l/h	16 bar	0,11	4x6 / 4x7	120	14 Watt	3 kg
1,2 l/h	10 bar	0,16	4x6 / 4x7	120	14 Watt	3 kg
1,5 l/h	6 bar	0,21	4x6 / 4x7	120	14 Watt	3 kg

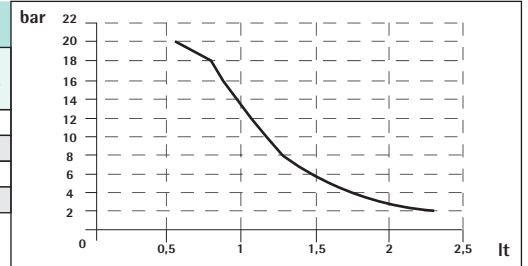

ATHENA AIR COND

PORTATE FLOW RATES	PRESSIONI PRESSURES	CC/IMP. CC/STROKE	CONNESSIONI CONNECTIONS	IMP./MIN STROKES/MIN.	ASSORBIMENTO CONSUPTION	PESO WEIGHT
2 l/h	10 bar	0,19	4x6	180	12,2 Watt	3 kg
3 l/h	7 bar	0,28	4x6	180	12,2 Watt	3 kg
6 l/h	2 bar	0,56	4x6	180	12,2 Watt	3 kg

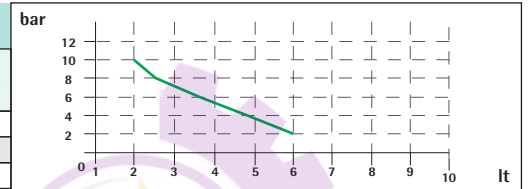

ATHENA 1

PORTATE FLOW RATES	PRESSIONI PRESSURES	CC/IMP. CC/STROKE	CONNESSIONI CONNECTIONS	IMP./MIN STROKES/MIN.	ASSORBIMENTO CONSUPTION	PESO WEIGHT
2,5 l/h	20 bar	0,35	4x6 / 4x7	120	14 Watt	3 kg
3 l/h	18 bar	0,42	4x6 / 4x7	120	14 Watt	3 kg
4,2 l/h	14 bar	0,58	4x6 / 4x7	120	14 Watt	3 kg

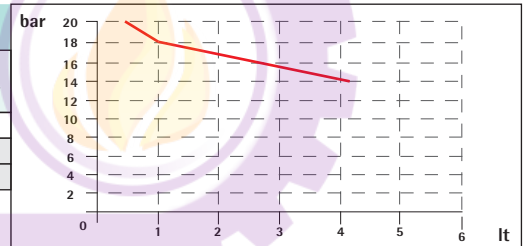

ATHENA 2

PORTATE FLOW RATES	PRESSIONI PRESSURES	CC/IMP. CC/STROKE	CONNESSIONI CONNECTIONS	IMP./MIN STROKES/MIN.	ASSORBIMENTO CONSUPTION	PESO WEIGHT
3 l/h	12 bar	0,31	4x6	160	14 Watt	3 kg
4 l/h	10 bar	0,42	4x6	160	14 Watt	3 kg
5 l/h	8 bar	0,52	4x6	160	14 Watt	3 kg
8 l/h	2 bar	0,83	4x6	160	14 Watt	3 kg

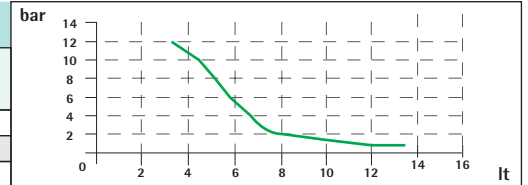

ATHENA 3

PORTATE FLOW RATES	PRESSIONI PRESSURES	CC/IMP. CC/STROKE	CONNESSIONI CONNECTIONS	IMP./MIN STROKES/MIN.	ASSORBIMENTO CONSUPTION	PESO WEIGHT
7 l/h	16 bar	0,39	4x6	300	28 Watt	4 kg
10 l/h	10 bar	0,55	4x6	300	28 Watt	4 kg
14 l/h	6 bar	0,78	4x6	300	28 Watt	4 kg
16 l/h	2 bar	0,89	4x6	300	28 Watt	4 kg

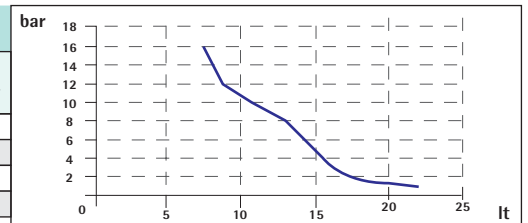

ATHENA 4

PORTATE FLOW RATES	PRESSIONI PRESSURES	CC/IMP. CC/STROKE	CONNESSIONI CONNECTIONS	IMP./MIN STROKES/MIN.	ASSORBIMENTO CONSUPTION	PESO WEIGHT
20 l/h	5 bar	1,11	8x12	300	28 Watt	4 kg
22 l/h	4 bar	1,22	8x12	300	28 Watt	4 kg
35 l/h	2 bar	1,94	8x12	300	28 Watt	4 kg
50 l/h	0,1 bar	2,78	8x12	300	28 Watt	4 kg

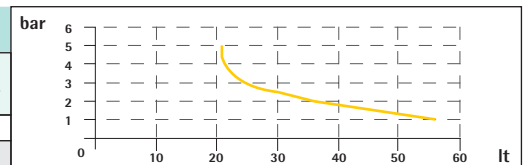



WATER TREATMENT DIVISION ATHENA SERIES

POMPE DOSATRICI ELETTROMAGNETICHE ELECTROMAGNETIC DOSING PUMPS

MODELLI MODELS



AT.BX

- **ANALOGICA A PORTATA COSTANTE**

- doppia regolazione manuale della portata 0÷20%, 0÷100%

- **ANALOGIC WITH COSTANT FLOW**

- 0÷20%, 0÷100% double manual flow regulation



AT.BL

- **ANALOGICA A PORTATA COSTANTE**

- doppia regolazione manuale della portata 0÷20%, 0÷100%
- predisposizione per sonda di livello con connettore ad attacco rapido

- **ANALOGIC WITH COSTANT FLOW**

- 0÷20%, 0÷100% double manual flow regulation
- quick connection level probe predisposition



AT.AM

- **ANALOGICA A PORTATA PROPORZIONALE**

- ad un segnale digitale (contatore lanciaimpulsi) con la possibilità di moltiplicare o dividere impulsi ricevuti (4:1 - 1:1 - 10:1 - 1xN)
- ad un segnale analogico (4÷20 mA) con la possibilità di regolare in percentuale la portata massima
- regolazione manuale della portata 0÷100%, funzione costante

- **ANALOGIC WITH PROPORTIONAL FLOW**

- to a digital signal (water meter) with the possibility multiply or divide the impulses received (4:1-1:1-10:1-1xN)
- to an analogic signal (4÷20 mA) with the possibility to regulate in percentage the maximum flow
- 0÷100% manual flow regulation, constant function



MODELLI MODELS



AT.AT AIR COND

- **ANALOGICA A PORTATA COSTANTE CON REGOLAZIONE MANUALE E DOSAGGIO TEMPORIZZATO CON DOPPIA REGOLAZIONE "T on - T off"**

- specifica per soddisfare le esigenze di piccoli volumi da dosare
- la riduzione del volume unitario permette di conservare inalterato il numero di colpi
- la qualità del dosaggio rimane garantita grazie al dispositivo antigoccia del nebulizzatore

- **ANALOGIC WITH COSTANT FLOW WITH MANUAL REGULATION OF THE FLOW AND DOSING SETTABLE IN TIME, WITH DOUBLE REGULATION "T on - T off"**

- specifically designed to satisfy the demands of small volume dosing
- the reduction of the unitary volume allows to preserve unchanged the number of the strokes
- the quality of the dosing is granted by the anti-drop system of the atomizer



AT.MT

- **DIGITALE A PORTATA PROPORZIONALE**

- ad un segnale analogico 0/4÷20 mA 20÷4 mA selezionabile
- ad un segnale digitale 1:n ; n:1 ; 1:c (batch) oppure direttamente in ppm
- regolazione digitale della portata, con possibilità di impostare la portata max

- **DIGITAL WITH PROPORTIONAL FLOW**

- to an analogic signal 0/4÷20 mA 20÷4 mA selectable
- to a digital signal 1:n ; n:1 ; 1:c (batch) or directly in ppm
- digital flow regulation, with yhe possibility to set the max flow



AT.BT

- **DIGITALE CON TIMER INTEGRATO**

- programmazione Giornaliera e Settimanale
- possibilità di Dosaggio ad Intervalli Programmati

- **DIGITAL WITH BUILT-IN TIMER**

- daily and Weekly Programming
- able to Dose with Timed Intervals



MODELLI E CARATTERISTICHE TECNICHE MODELS AND TECHNICAL FEATURES

AT.PR

- **DIGITALE A PORTATA PROPORZIONALE CON STRUMENTO pH/Rx**

- range di misura pH 0÷14 - Rx -999÷+999 mV
- compensazione automatica/manuale della temperatura (pH)
- uscita 4÷20 mA su tutta la scala per registrazione
- Calibrazione automatica/manuale con indicazione efficienza della sonda

- **DIGITAL PROPORTIONAL FLOW WITH pH/Rx INSTRUMENTS**

- pH 0÷14 - Rx -999÷+999 mV measuring range
- manual/automatic temperature compensation (pH)
- 4÷20 mA output on all the recording scale
- manual/automatic calibration with probe efficiency evaluation

- **DISPONIBILE LA NUOVA FUNZIONE DI COMANDO "TIMER RITARDO DOSAGGIO DELLA POMPA"**

● Alcune volte, all'accensione della pompa dosatrice, è necessario attendere la stabilità di misura chimica per effettuare un corretto dosaggio. Per facilitare il lavoro dell'installatore è disponibile un Timer nel Menù Impostazioni per ritardare il dosaggio all'accensione della pompa

- **AVAILABLE THE NEW SOFTWARE FUNCTION "TO SET DELAY TIME DOSING ABOUT PUMP"**

● Sometimes when switching the dosing pump on, we need to wait for the chemical measure stability in order to make a proper dosage. To make the installer work easy, it is available a Timer into Pump Menu in order to delay dosing action when switching the dosing pump on.

AT.MP

- **DIGITALE A PORTATA PROPORZIONALE CON STRUMENTO PER SONDE POTENZIOSTATICHE**

- impostazione misura di: cloro, perossido di idrogeno e acido peracetico
- ingresso sonda temperatura PT100 per compensazione automatica
- ripetizione allarme
- ingresso digitale ON-OFF per controllo remoto
- uscita analogica in corrente 4÷20 mA

- **DIGITAL PROPORTIONAL FLOW WITH INSTRUMENTS FOR POTENTIOSTATIC SENSORS**

- able to set measurement for: chlorine, hydrogen peroxide and peracetic acid
- PT100 probe enables automatic compensation of temperature
- repetition intervals for alarm
- remoted controlled digital ON-OFF input
- 4÷20 mA analogic output





ELECTROMAGNETIC PRODUCTS ATHENA.12 VDC SERIES



CARATTERISTICHE GENERALI - GENERAL FEATURES

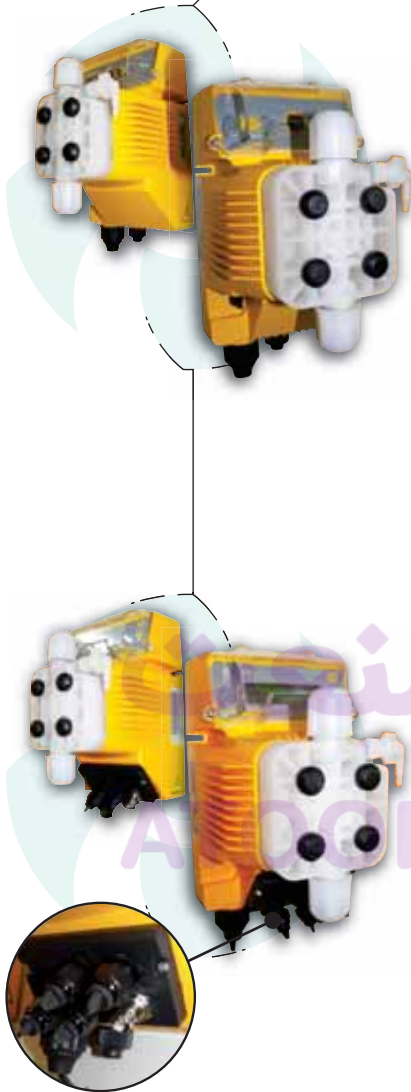

AT.BX 12 VDC

● ANALOGICA A PORTATA COSTANTE e INTERFACCIA ANALOGICA

- Doppia regolazione manuale della portata 0÷20%, 0÷100% ● Valvola di Spurgo Manuale ● Testa in PVDF ● Diaframma in PTFE ● Sfere in Ceramica ● Protezione IP65

● ANALOGIC WITH COSTANT FLOW and ANALOG INTERFACE

- 0÷20%, 0÷100% double manual flow regulation ● Manual Priming Valve ● PVDF Pump Head ● PTFE Diaphragm ● Ceramic Ball ● IP65 Protection

AT.MR 12 VDC

● DIGITALE A PORTATA PROPORZIONALE (Funzioni Pompa AT.MT e AT.PR)

- Portata Costante regolabile manualmente, Portata Proporzionale ad un Segnale Esterno, Analogico (4÷20 mA) o Digitale (Contatore Lanciaimpulsi) ● Modalità Batch ● Funzione Timer ● Dosaggio in ppm ● Ingresso di Controllo Remoto (START-STOP) ● Strumento pH/Redox Integrato ● Ingresso Selezionabile per Sonda PT100 o PT1000 (Termocompensazione)

● DIGITAL PROPORTIONAL FLOW (AT.MT and AT.PR Pump Functions)

- Constant Flow Rate manuell adjustable, Proportional Flow Rate according to an external Analog (4÷20 mA) or Digital Signal (Water Meter) ● Batch Mode ● Timer Function ● ppm Proportional Dosing ● Input ON-OFF (Remote Control) ● pH/Redox Control Meter on board ● PT100 or PT1000 (Selectable) Probe Input (Thermal-Compensation)

CARATTERISTICHE TECNICHE - TECHNICAL FEATURES

DATI RILEVATI CON ACQUA A TEMPERTATURA AMBIENTE CON ALTEZZA ASPIRAZIONE 1,5 mt

ALL DATA HAS TO BE CONSIDERED AT AMBIENT TEMPERATURE WATER AND 1,5 mt SUCTION HEIGHT

ATHENA 12 VDC

PORTATE FLOW RATES	PRESSIONI PRESSURES	CC/IMP. CC/STROKE	CONNESSIONI CONNECTIONS	IMP./MIN STROKES/MIN.	CONSUMO CONSUPTION	PESO WEIGHT
3 l/h	10 bar	0,25	4x6	200	6,5 Watt	3 kg
4 l/h	8 bar	0,33	4x6	200	6,5 Watt	3 kg
5 l/h	5 bar	0,42	4x6	200	6,5 Watt	3 kg

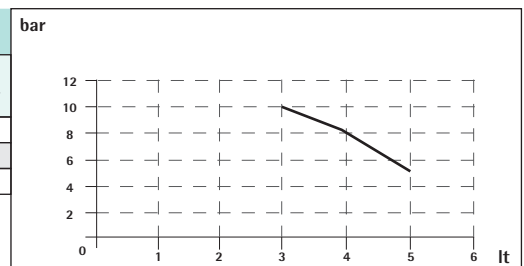



WATER TREATMENT DIVISION

GEA SERIES

POMPE DOSATRICI ELETTROMAGNETICHE A CORSA E FREQUENZA REGOLABILI
ELECTROMAGNETIC DOSING PUMPS WITH ADJUSTABLE STROKES AND FREQUENCY



CARATTERISTICHE GENERALI GENERAL FEATURES

POMPE DOSATRICI ELETTROMAGNETICHE A FREQUENZA E CORSA REGOLABILI

GEA

- 5 modelli con portate da 0,4 a 54 lt/h; pressioni fino a 20 bar
- Testa e kit in PVDF, permettono la compatibilità con i più importanti prodotti chimici
- Le Sfere in ceramica garantiscono una perfetta tenuta ed ottima compatibilità chimica
- Lunga vita del diaframma in teflon: testato per 5 anni di funzionamento continuo
- L'innovativo design del diaframma ed il sistema di produzione garantiscono un'eccezionale performance di lavoro
- La sostituzione continua del diaframma non è richiesta
- Manutenzione ridotta
- Alimentazione 100/240 vac 50/60Hz

GEA.R

- pompa dosatrice elettromagnetica con regolazione della frequenza e della corsa
- 1 modello con portate da 8 a 25 lt/h e pressioni fino a 14 bar
- La doppia regolazione permette un dosaggio preciso in un ampio range di applicazioni

ELECTROMAGNETIC DOSING PUMP WITH ADJUSTABLE FREQUENCY AND STROKES

GEA

- 5 model that cover 0,4 to 54 l/h with an output pressure up to 20 Bar
- PVDF head and kit is suitable for almost all chemical used in Industrial, Waste Water Treatment and potable water applications
- The use of Ceramic Balls improves the pumping reliability and the chemical compatibility of the whole liquid end
- Long life diaphragm, tested to give 5 years working life
- The advanced design and the manufacturing process allows the diaphragm to have a unique life expectancy
- Routine diaphragm replacement no longer required
- Reduced maintenance
- 100/240 VAC 50/60Hz tension Input

GEA.R

- Electromagnetic pump with ADJUSTABLE frequency and strokes
- 1 model with flow rates from 8 to 25lt/h and pressures up to 14 bar
- Double regulation allows a perfect dosing in a wide range of uses



WATER TREATMENT DIVISION GEA SERIES

POMPE DOSATRICI ELETTROMAGNETICHE ELECTROMAGNETIC DOSING PUMPS



MODELS AND TECHNICAL FEATURES GEA LOW FLOW

UK version

FLOW RATE	PRESSURES	CC/STROKE	CONNECTIONS	STROKES/MIN.	CONSUPTION	WEIGHT
0,4 L/H	20 BAR	0,06	4x6/4x7	120	14 WATT	3 kg
0,8 L/H	16 BAR	0,11	4x6/4x7	120	14 WATT	3 kg
1,2 L/H	10 BAR	0,16	4x6/4x7	120	14 WATT	3 kg
1,5 L/H	6 BAR	0,21	4x6/4x7	120	14 WATT	3 kg

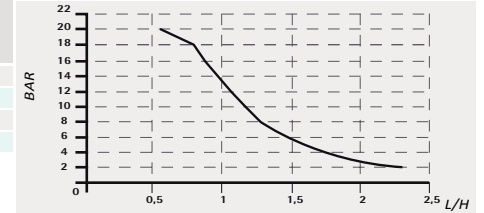

MODELS AND TECHNICAL FEATURES GEA 1

UK version

FLOW RATE	PRESSURES	CC/STROKE	CONNECTIONS	STROKES/MIN.	CONSUPTION	WEIGHT
1,5 L/H	20 BAR	0,21	4x6/4x7	120	14 WATT	3 kg
2 L/H	18 BAR	0,28	4x6/4x7	120	14 WATT	3 kg

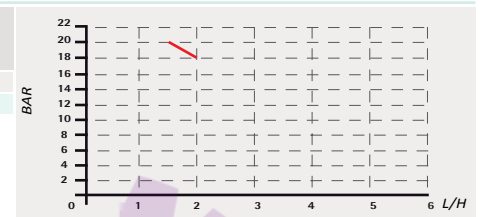

MODELS AND TECHNICAL FEATURES GEA 2

UK version

FLOW RATE	PRESSURES	CC/STROKE	CONNECTIONS	STROKES/MIN.	CONSUPTION	WEIGHT
3 L/H	12 BAR	0,31	4x6	160	14 WATT	3 kg
4 L/H	10 BAR	0,42	4x6	160	14 WATT	3 kg
5 L/H	8 BAR	0,52	4x6	160	14 WATT	3 kg
8 L/H	2 BAR	0,83	4x6	160	14 WATT	3 kg

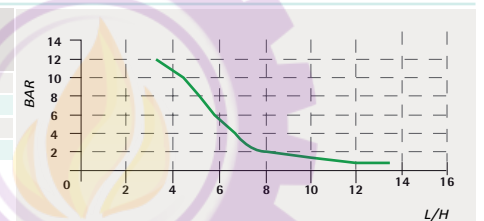

MODELS AND TECHNICAL FEATURES GEA 3

UK version

FLOW RATE	PRESSURES	CC/STROKE	CONNECTIONS	STROKES/MIN.	CONSUPTION	WEIGHT
7 L/H	16 BAR	0,39	4x6	300	28 WATT	4 kg
10 L/H	10 BAR	0,55	4x6	300	28 WATT	4 kg
14 L/H	6 BAR	0,78	4x6	300	28 WATT	4 kg
16 L/H	2 BAR	0,89	4x6	300	28 WATT	4 kg

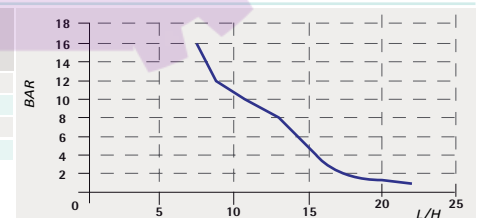

MODELS AND TECHNICAL FEATURES GEA 4

UK version

FLOW RATE	PRESSURES	CC/STROKE	CONNECTIONS	STROKES/MIN.	CONSUPTION	WEIGHT
8 L/H	5 BAR	1,11	8x12	300	28 WATT	4 kg
10 L/H	4 BAR	1,22	8x12	300	28 WATT	4 kg
12 L/H	2 BAR	1,94	8x12	300	28 WATT	4 kg
25 L/H	0,1 BAR	2,78	8x12	300	28 WATT	4 kg

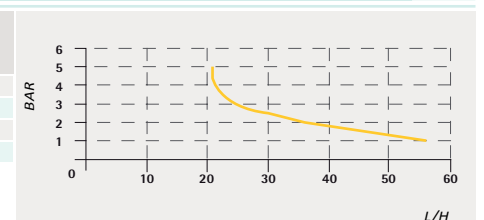

MODELS AND TECHNICAL FEATURES GEA R

UK version

FLOW RATE	PRESSURES	CC/STROKE	CONNECTIONS	STROKES/MIN.	CONSUPTION	
					min	max
8 L/H	14 BAR	0,49	4x6	270	15 WATT	26 WATT
10 L/H	10 BAR	0,62	4x6	270	15 WATT	26 WATT
12 L/H	6 BAR	0,74	4x6	270	15 WATT	26 WATT
25 L/H	2 BAR	1,54	4x6	270	15 WATT	26 WATT





GEA - Gamma analogica GEA - Analogue range



MODELLO E CARATTERISTICHE MODEL AND TECHNICAL FEATURES

GEA BL

- Pompa dosatrice analogica a portata costante
- Doppia regolazione manuale della portata (0÷20% or 0÷100%)
- Predisposizione per sonda di livello con connettore ad attacco rapido
- Analogue dosing pump with constant flow rate manually adjustable by control dial on the front panel
- 2 frequency range (0÷20% or 0÷100%)
- Power-ON led indicator and level control input

آتور صنعت
ATOORSANAT

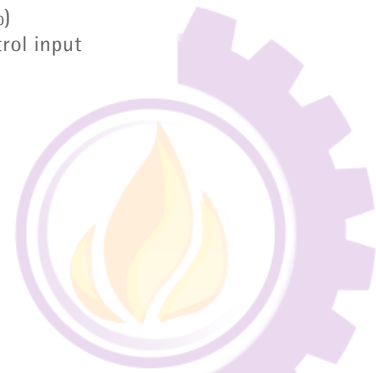

MODELLO E CARATTERISTICHE MODEL AND TECHNICAL FEATURES

GEA AM

- Pompa dosatrice analogica a portata proporzionale
- Ad un segnale digitale (contatore lanciainpuls) con la possibilità di moltiplicare o dividere gli impulsi ricevuti
- Ad un segnale analogico (4÷20 mA) con la possibilità di regolare in percentuale la portata massima
- Regolazione manuale della portata 0÷100
- Analogue dosing pump with proportional flow rate according to
- a digital pulse signal (e.g. from water meter)
- an external analog (4÷20 mA)
- control dial (percentage and "n" value in multiplication mode)
 - in division mode (1, 4, 10 = n)
 - 1 in multiplication mode (n=1)
 - 1 for proportional 4÷20 mA signal
 - 1 for constant functionality
- Pacing function adjustable by dip switch

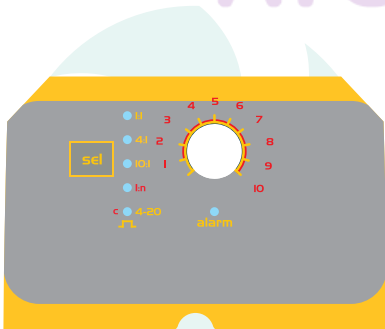



GEA - Gamma digitale GEA - Digital range

MODELLO E CARATTERISTICHE MODEL AND TECHNICAL FEATURES

GEA MT

- Digitale a portata proporzionale
 - Ad un segnale analogico 0/4÷20 mA 20÷4 mA selezionabile
 - Ad un segnale digitale 1:n ; n:1 ; 1:c (batch) oppure direttamente in ppm
 - Regolazione digitale della portata, con possibilità di impostare la portata massima
- Digital pump with proportional flow rate
 - according to an external analog (4÷20 mA)
 - digital pulse signal (e.g. from water meter)
 - Digital flow rate regulation,



MODELLO E CARATTERISTICHE MODEL AND TECHNICAL FEATURES

GEA PR

- Digitale a portata proporzionale con strumento pH/Rx
- Range di misura pH 0÷14 - Rx -999÷999 mV
- Compensazione automatica/manuale della temperatura (pH)
- Uscita 4÷20 mA su tutta la scala per registrazione
- Compensazione automatica/manuale con indicazione efficienza della sonda

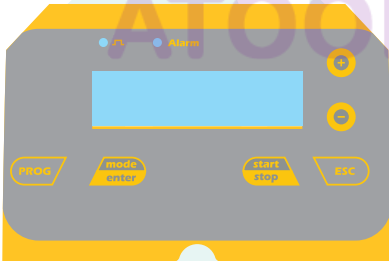

- Digital pump with proportional flow rate with pH/Redox control meter built in
- Measurement range pH 0÷14 - Rx -999÷999 mV
- Automatic/manual compensation of thermal temperature (pH)
- 4÷20 mA output for measure transmission
- Automatic/manual compensation with probe efficiency indicator

MODELLO E CARATTERISTICHE MODEL AND TECHNICAL FEATURES

GEA BT

- Digitale con timer integrato
- Programmazione giornaliera e settimanale, max 10 interventi nei quali è possibile impostare orario, quantità e tempo di dosaggio
- Possibilità di comandare un'elettrovalvola attraverso un'uscita a relè
- Possibilità di dosaggio ad intervalli programmati

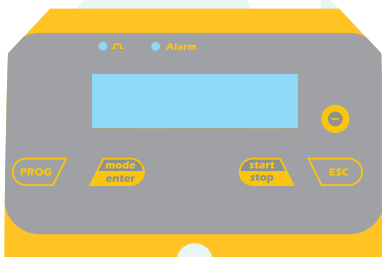

- Digital pump with integrated timer
- Daily and weekly programmable with timed intervals dosing
- Able to control an electrovalve by a relay output



ELECTROMAGNETIC PRODUCTS GEA SERIES

آتور صنعت
ATOORSANAT



GEA R - Gamma analogica GEA R - Analogue range

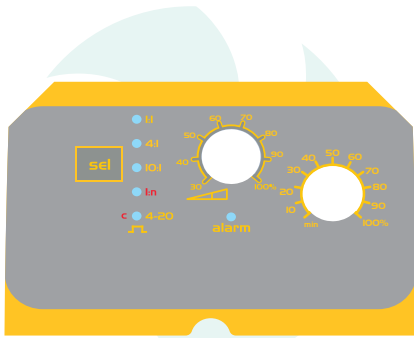

MODELLO E CARATTERISTICHE MODEL AND TECHNICAL FEATURES

GEA R AM

- Analogica a portata proporzionale
 - Ad un segnale digitale (contatore lanciainpuls) con la possibilità di moltiplicare o dividere gli impulsi ricevuti
 - Ad un segnale analogico (4÷20 mA) con la possibilità di regolare in percentuale la portata massima
 - Regolazione manuale della portata massima 0÷100
 - **REGOLAZIONE ELETTRONICA DELLA CORSA**
-
- Analogue with proportional flow rate
 - according to an external analog (4÷20 mA)
 - digital pulse signal (e.g. from water meter)
 - **ELECTRONIC STROKE LENGTH REGULATION**

آتور صنعت
ATOORSANAT

GEA R - Gamma digitale GEA R - Digital range

MODELLO E CARATTERISTICHE MODEL AND TECHNICAL FEATURES

- Digitale a portata proporzionale
- Ad un segnale analogico 0/4÷20 mA 20÷4 mA selezionabile
- Ad un segnale digitale 1:n ; n:1 ; 1:c (batch) oppure direttamente in ppm
- Regolazione digitale della portata, con possibilità di impostare la portata massima
- **REGOLAZIONE ELETTRONICA DELLA CORSA**

- Digital pump with proportional flow rate
- according to an external analog (4÷20 mA)
- digital pulse signal (e.g. from water meter)
- Digital flow rate regulation
- **ELECTRONIC STROKE LENGTH REGULATION**





WATER TREATMENT DIVISION HYDRASERIES

POMPE DOSATRICI ELETTROMAGNETICHE ELECTROMAGNETIC DOSING PUMPS



CARATTERISTICHE GENERALI GENERAL FEATURES



- **TESTA IN PVDF**
- **SFERE IN CERAMICA** affidabilità del dosaggio e compatibilità chimica
- **DIAFRAMMA in PTFE** resistenza e compatibilità con tutti i prodotti chimici
- **REGOLAZIONE MANUALE DELLA PORTATA 0÷100%**
- **VALVOLA DI SPURGO MANUALE**
- **MONTAGGIO A MURO** Con staffa di fissaggio (inclusa)
- **PVDF PUMP HEAD**
- **CERAMIC BALL** full chemical compatibility
- **PTFE DIAPHRAGM** unique life expectancy and compatibility with most chemicals
- **FLOW RATE MANUAL ADJUSTMENT 0÷100%**
- **MANUAL PRIMING VALVE**
- **WALL MOUNTING** with fixing bracket (included)

MODELLI E CARATTERISTICHE TECNICHE MODELS E TECHNICAL FEATURES

PORTATE FLOW RATES	PRESSIONI PRESSURES	CC/IMP. CC/STROKE	CONNESSIONI CONNECTIONS	IMP./MIN STROKES/MIN.	ASSORBIMENTO CONSUPTION	PESO WEIGHT	DIMENSIONI DIMENSIONS	PROTEZIONE PROTECTION DEGREE
5 l/h	8 bar	0,52	4x6	160	12 Watt	3 kg	190,5x92x135,5 mm	IP65
3 l/h	10 bar	0,52	4x6	160	12 Watt	3 kg	190,5x92x135,5 mm	IP65

ALIMENTAZIONE POWER SUPPLY

HY.BX 230 Vac 50 Hz, Assorbimento 12W **HY.BL, HY.MA, HY.BC, HY.MT, HY.PR** 100÷240 Vac, 50/60 Hz (con assorbimento ridotto in quanto il magnete assorbe solo la quantità di energia richiesta per effettuare il dosaggio nelle condizioni dell'installazione eccellenti) Assorbimento 14W

HY.BX 230 Vac 50 Hz, Consumption 12W **HY.BL, HY.MA, HY.BC, HY.MT, HY.PR** 100÷240 Vac, 50/60 Hz (with reduced power consumption as the solenoid only draws the required power to activate the pump, based on the working conditions) Consumption 14W



ELECTROMAGNETIC PRODUCTS

MODELLI E CARATTERISTICHE TECNICHE - MODELS AND TECHNICAL FEATURES

HY.BX

• pompa dosatrice elettromagnetica analogica a dosaggio costante, con regolazione della portata tramite manopola posta sul pannello frontale. Indicatore LED di funzionamento

• analogue dosing pump with constant flow rate manually adjustable by control knob on the front panel, POWER-ON LED indicator

HY.BL

• pompa dosatrice elettromagnetica analogica a dosaggio costante, con regolazione della portata tramite manopola posta sul pannello frontale. • 2 intervalli di portata: 0÷20% con selettore in posizione "P", 0÷100% con selettore in posizione "C", Microswitch interno • LED indicatore di funzionamento e predisposizione per sonda di livello

• analogue dosing pump with constant flow rate manually adjustable by control knob on the front panel • 2 flow rate range: 0÷20% with switch in "P" position, 0÷100% with switch in "C" position, Internal Microswitch • POWER-ON LED indicator and level control input

HY.MA

• pompa dosatrice elettromagnetica analogica a dosaggio costante, con regolazione della portata tramite manopola posta sul pannello frontale, e proporzionale in base ad un segnale analogico esterno (4÷20 mA), LED indicatore di funzionamento e predisposizione per sonda di livello • 2 modalità di funzionamento: COSTANTE (selettore in "C") la pompa effettua un dosaggio costante, erogando in base alla percentuale selezionata con potenziometro - PROPORZIONALE (selettore in "P") la pompa dosa proporzionalmente ad un segnale (4÷20 mA), Microswitch interno

• analogue dosing pump with constant flow rate manually adjustable by control knob on the front panel and proportional flow rate according to an external analogue (4÷20 mA), POWER-ON LED indicator and level control input • 2 different operating modes are: COSTANT (switch in "C" position) the pump constantly dispenses the percentage selected with potentiometer - PROPORTIONAL (switch in "P" position) the pump doses proportionally to the input signal (4÷20 mA), Internal Microswitch

HY.BC

• pompa dosatrice elettromagnetica analogica a dosaggio costante, regolabile manualmente, e proporzionale a segnale digitale (es: contatore lanciainpuls). Indicatore Led di funzionamento e predisposizione per sonda di livello • 2 modalità di funzionamento: COSTANTE (selettore in "C") la pompa effettua un dosaggio costante, erogando in base alla percentuale selezionata con potenziometro - PROPORZIONALE (selettore in "P") la pompa dosa proporzionalmente ad un segnale digitale (modalità divisione 4=n)

• analogue dosing pump with constant flow rate manually adjustable and proportional flow rate according to a digital signal (e.g. from water meter), Power-ON Led indicator and level control input • 2 different operating modes are: COSTANT (switch in "C" position) the pump constantly dispenses the percentage selected with potentiometer - PROPORTIONAL (switch in "P" position) the pump doses proportionally to the digital input signal (Division mode 4=n)





MODELLI E CARATTERISTICHE TECNICHE - MODELS AND TECHNICAL FEATURES

HYDRA.MT



- **pompa dosatrice elettromagnetica digitale a dosaggio costante e proporzionale** tramite un segnale esterno analogico (0/4÷20 mA o 20÷4/0 mA) o un segnale digitale (livello acqua, segnale di voltaggio)
- Dosaggio temporizzato attraverso un timer programmabile settimanalmente
- Dosaggio ppm
- Dosaggio Batch
- Statistiche
- Password
- Segnale remoto ON/OFF

- **digital dosing pump with manually adjustable constant flow rate and proportional dosing** according to an external analog (0/4÷20 mA or 20÷4/0 mA) or digital signal (water meter, hall sensor or voltage signal)
- timed dosing with a weekly programmable timer
- ppm dosage
- batch dosage
- statistics
- password
- Remote ON/OFF input

آتور صنعت
ATOORSANAT

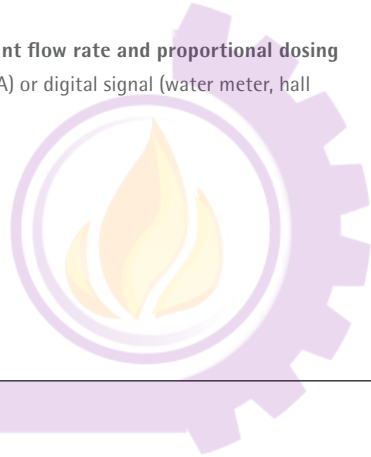

HYDRA.PR



- **Pompa dosatrice digitale con portata regolabile manualmente e dosaggio proporzionale** basato sulla misurazione del pH o sul valore ORP. Compensazione della temperatura
- Sonda temperatura PT100 (su richiesta)
- Input ON-OFF (controllo remoto)
- **Digital dosing pump with manually adjustable flow and proportional dosing** according to the measured pH or ORP value. Temperature compensation
- PT100 temperature probe (upon request)
- ON-OFF input (remote control)



WATER TREATMENT DIVISION

OLIMPIA SERIES

POMPE DOSATRICI ELETTROMAGNETICHE ELECTROMAGNETIC DOSING PUMPS

CARATTERISTICHE GENERALI GENERAL FEATURES



- ANALOGICA A PORTATA COSTANTE
- TESTA IN PVDF adatta per i prodotti chimici usati nelle applicazioni industriali, nel trattamento acque e nella potabilizzazione
- CASSA IN POLIPROPILENE ignifuga e anti-acido
- REGOLAZIONE MANUALE DELLA PORTATA 0÷100
- VALVOLA DI ADESCAMENTO MANUALE
- ALIMENTAZIONE ED INGRESSO SONDA DI LIVELLO con attacco rapido
- LED CON STATO DI FUNZIONAMENTO
- PROTEZIONE IP65

- ANALOGIC WITH CONSTANT FLOW
- PVDF* PUMP HEAD suitable for chemicals used in industrial Waste Water Treatment and Potable water applications
- FIREPROOF AND ANTI-ACID POLYPROPYLENE BOX
- MANUALLY ADJUSTABLE FLOW RATE 0÷100
- MANUAL PRIMING VALVE
- POWER SUPPLY AND LEVEL PROBE INLET with Quick connection
- WORKING STATE LED
- IP65 PROTECTION DEGREE

MODELLI E CARATTERISTICHE TECNICHE MODELS E TECHNICAL FEATURES

OL.LOW NOISE

PORTATE FLOW RATES	PRESSIONI PRESSURES	CC/IMP. CC/STROKE	CONNESSIONI CONNECTIONS	IMP./MIN STROKES/MIN.	ASSORBIMENTO CONSUPTION	ALIMENTAZIONE POWER SUPPLY
0,2 l/h	7 bar	0,60	4x6	20	14 Watt	100÷240VAC 50/60HZ 24VAC

OL.LOW FLOW

PORTATE FLOW RATES	PRESSIONI PRESSURES	CC/IMP. CC/STROKE	CONNESSIONI CONNECTIONS	IMP./MIN STROKES/MIN.	ASSORBIMENTO CONSUPTION	ALIMENTAZIONE POWER SUPPLY
0,5 l/h	7 bar	0,41	4x6	20	14 Watt	100÷240VAC 50/60HZ 24÷48VAC

OL.BP

PORTATE FLOW RATES	PRESSIONI PRESSURES	CC/IMP. CC/STROKE	CONNESSIONI CONNECTIONS	IMP./MIN STROKES/MIN.	ASSORBIMENTO CONSUPTION	ALIMENTAZIONE POWER SUPPLY
5 l/h	5 bar	0,60	4x6	140	14 Watt	100÷240VAC 50/60HZ 24÷48VAC
2 l/h	7 bar	0,33	4x6	100	14 Watt	100÷240VAC 50/60HZ 24÷48VAC

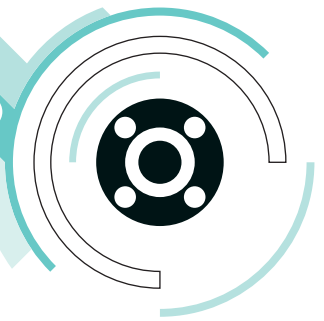

ACCESSORISTICA - ACCESSORIES

AC.VI

- valvola iniezione a sfera ceramica e molla in hastelloy 1/2"-3/8"
- 1/2"-3/8" injection valve with ceramic ball and hastelloy spring

CONNESSIONI CONNECTIONS	CORPO BODY	TENUTE SEALS
4x6/8x12	PVDF-C*	FPM
	PVDF	EPDM

AC.FP

- valvola di fondo con filtro
- foot valve with filter

CONNESSIONI CONNECTIONS	CORPO BODY	TENUTE SEALS
4x6/8x12	PVDF-C*	FPM
	PVDF	EPDM

AC.VSA

- corpo pompa con autospurgo, riduzione della portata in funzione della quantità di gas presente
- automatic air bleed valve, flow reduction, according to the quality of air in the liquid

CONNESSIONI CONNECTIONS	CORPO BODY	TENUTE SEALS
4x6/8x12	PVC	FPM
		EPDM

AC.SF

- sensore di flusso
- flow sensor

CONNESSIONI CONNECTIONS	CORPO BODY	TENUTE SEALS
4x6/8x12	PVC	FPM

AC.VIE

- valvola iniezione estraibile con intercettatore
- Extractable injection valve with ball valve

CONNESSIONI CONNECTIONS	CORPO BODY	TENUTE SEALS
1/2" g.m. IN/OUT	PVC	FPM
		EPDM

AC.VS

- valvola di contropressione, membrana PTFE, 500 lt/h, 0,5÷10 bar
- back-pressure valve, PTFE diaphragm, 500 lt/h, 0,5÷10 bar

CONNESSIONI CONNECTIONS	CORPO BODY	TENUTE SEALS
4x6/8x12	PVC	FPM
	PVDF	EPDM

AC.VM

- valvola multifunzione, antisifone, contropressione, sicurezza, 5/10/18 bar
- multifunction valve, antisiphon, backpressure, safety, 5/10/18 bar

CONNESSIONI CONNECTIONS	CORPO BODY	TENUTE SEALS
4x6/8x12	PP	PTFE

PRIMING AID

- capacità 300 ml
- 300 ml capacity

CONNESSIONI CONNECTIONS	CORPO BODY	TENUTE SEALS
4x6/8x12	PVC	FPM



ACCESSORISTICA ACCESSORIES



NEBULIZZATORE ATOMIZER

- Realizzato in materiali plastici di alta qualità, resistenti ai prodotti chimici normalmente utilizzati in agricoltura ed alle condizioni climatiche più difficili • Grandezza ugello: 0.62mm • Alla pressione di 4 bar il nebulizzatore distribuisce gocce di diametro 90 micron
- Made with high quality plastics, resistant to all the chemicals normally used in agriculture, even in the most extreme weather conditions • Nozzle dimensions: 0.62 mm • With a back pressure of 4 bar the atomizer produces drops of about 90 microns



AC.SL

- sonda di livello fornita di cavo polare (2 mt) con staffa
- Floating level probe with bipolar cable (2 mt) with support



AC.PR

- prolunga di iniezione
- injection extension



AC.ST

- staffa di montaggio
- base mounting bracket



TUBI TUBES

- tubo di mandata PE 4x6/8x12 mm (100 mt)
- tubo di aspirazione PVC 4x6/8x12 mm (100 mt)
- PE delivery tube 4x6/8x12 mm (100 mt)
- PVC suction tube 4x6/8x12 mm (100 mt)

آتور صنعت
ATOORSANAT





GRUPPI DI DOSAGGIO / DOSING UNITS



DM UNITS

● **GRUPPO DI DOSAGGIO COMPOSTO DA:**

- pompa ATHENA (PVDF), Serbatoio, Staffa orizzontale per montaggio pompa, Supporto in PVC, Agitatore, Lancia di aspirazione completa di sonda di livello, Kit accessori

● **DOSING UNIT COMPOSED BY:**

- ATHENA pump, Tank, horizontal Mounting Bracket, PVC support, Mixer, Suction group with level probe, Complete accessories kit

NIKESERIES

POMPE PERISTALTICHE / PERISTALTIC PUMPS

CARATTERISTICHE GENERALI / GENERAL FEATURES



- CASSA IN POLIPROPILENE IGNIFUGA E ANTIACIDO
- INTERRUTTORE ON/OFF COMPLETAMENTE PROTETTO
- PROTEZIONE IP65
- VELOCITÀ VARIABILE 10÷100%
- TRIMMER AD ALTA RISOLUZIONE per la regolazione della velocità e LED Funzionamento/Alimentazione
- DIMENSIONI 112 x 90 x 90 mm

- FIREPROOF AND ANTI-ACID POLYPROPYLENE BOX
- ON/OFF SWITCH COMPLETELY PROTECTED
- IP65 PROTECTION
- VARIABLE SPEED 10÷100%
- HIGH RESOLUTION TRIMMER for speed regulation and power Supply/Working LED
- DIMENSIONS 112 x 90 x 90 mm

CARATTERISTICHE TECNICHE / TECHNICAL FEATURES

MODELLI MODELS	PORTATE FLOW RATES	PRESSIONI PRESSURES	ALIMENTAZIONE POWER SUPPLY	DISLOCAMENTO PER GIRO REVOLUTION DISPLACEMENT	ASSORBIMENTO CONSUPTION	CONNESSIONE CONNECTION	PESO WEIGHT
NK.LP 120	0,54÷7,2 lt/h	1 bar	100÷240 Vac 24 Vac	2,5 ml	15 W	4x6	1,5 Kg
NK.LP 180	0,72÷10,8 lt/h	1 bar	100÷240 Vac 24 Vac	2,5 ml	15 W	4x6	1,5 Kg



WATER TREATMENT DIVISION

NIKE SERIES

POMPE PERISTALTICHE PERISTALTIC PUMPS

CARATTERISTICHE GENERALI GENERAL FEATURES

NIKE.M PRO

- SPECIFICA PER IL MANTENIMENTO DI PISCINE E PER IL DOSAGGIO DI FLOCCULANTE, ANTIALGHE, ARIA CONDIZIONATA ED ESSENZE

- SPECIFICALLY DESIGNED FOR SWIMMING POOL MAINTENANCE AND DOSING OF FLOCCULENT, ANTI-ALGAE, AIR CONDITIONING AND ESSENCES

NIKE.M TEMP

- TRATTAMENTO PISCINE SPA, DOCCE, LAVAPIEDI ED ESSENZE
- DOSAGGIO TEMPORIZZATO E FUNZIONE BATCH (1 min)

- SPA SWIMMING POOL, SHOWER AND ESSENCES TREATMENT

- TEMPORISED DOSING AND BATCH FUNCTION (1 min)



آتور صنعت
ATOORSANAT

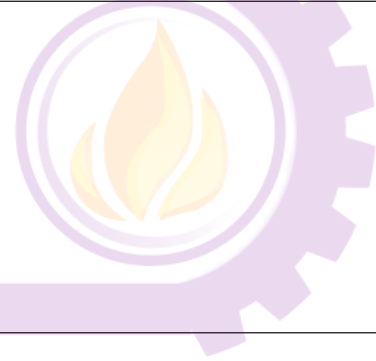

MODELLI E CARATTERISTICHE TECNICHE MODELS E TECHNICAL FEATURES

MODELLI MODELS	PORTATE FLOW RATES	PRESSIONI PRESSURES	ALIMENTAZIONE POWER SUPPLY
NK.M PRO	2,5÷25 ml/h	1,5 bar	100÷240 Vac
	15,1÷151 ml/h	1,5 bar	100÷240 Vac
	180÷1800 ml/h	1,5 bar	100÷240 Vac
	396÷3960 ml/h	1,5 bar	100÷240 Vac
	900÷9000 ml/h	1,5 bar	100÷240 Vac
NK.M TEMP	4-2-1 lt/h SETTABILE SELECTABLE	1,5 bar	100÷240 Vac



CARATTERISTICHE GENERALI - GENERAL FEATURES



- REGOLAZIONE DELLA VELOCITÀ DI DOSAGGIO VIA SOFTWARE
- CONTROLLO DEL LIVELLO SERBATOIO
- INTERRUTTORE "ON/OFF/ADESCAMENTO"
- DISPLAY 16x2 (BLU/BIANCO)
- INGRESSO IN TENSIONE 240 Vac "segnale elettrico dalla pompa di ricircolo"
- ALLARME REMOTO VIA RELÉ (Contatto Pulito)
- SETTAGGIO DEI PARAMETRI VIA MENÙ
- DOSING SPEED REGULATION VIA SOFTWARE
- TANK LEVEL CONTROL
- ON/OFF/SWITCH-PRIMING
- 16x2 DISPLAY (BLUE/WHITE)
- TENSION INPUT 240 Vac "electrical signal from circulating pumps"
- REMOTE ALARM THROUGH RELAYS (Dry Contact)
- SETTING OF THE PARAMETERS VIA MENÙ

CARATTERISTICHE TECNICHE - TECHNICAL FEATURES

PORTATE FLOW RATES	PRESSIONI PRESSURES	ALIMENTAZIONE POWER SUPPLY
2,5÷25 ml/h	1,5 bar	100÷240 Vac
15,1÷151 ml/h	1,5 bar	100÷240 Vac
180÷1800 ml/h	1,5 bar	100÷240 Vac
396÷3960 ml/h	1,5 bar	100÷240 Vac
900÷9000 ml/h	1,5 bar	100÷240 Vac

MODELLI - MODELS

BIO.PROP

- **SISTEMA DI DOSAGGIO COSTANTE E PROPORZIONALE**
- Applicazioni Trattamento Acque, Acqua Ossigenata per Piscine • Ingresso Segnale in Corrente (0÷20 mA) per Dosaggio Proporzionale • Ingresso in Frequenza (Contatore Lancia-Impulsi) per Dosaggio Proporzionale • Funzione Batch
- **COSTANT AND PROPORTIONAL DOSING SYSTEM**
- Water Treatment Applications, Peroxide for Swimming Pools • Input mA Signal Current (0÷20 mA) to Control Flow Rate Pump in Proportional Mode • Input Volage Free (Pulse Signal) to Control Flow Rate Pump in Proportional Mode • Batch Function

BIO.TEMP

- **SISTEMA DI DOSAGGIO TEMPORIZZATO**
- Dosaggio Flocculante ed Essenze • Dosaggio con Orologio settimanale • Relé Funzione Attivazione "AFTER/BEFORE"
- **TEMPORISED DOSING SYSTEM**
- Flocculent and Essences Dosing • Dosing with Weekly Timer • Activation Relays "AFTER/BEFORE"



WATER TREATMENT DIVISION NIKE.STEP SERIES

PERISTALTIC METERING PUMP DRIVEN BY A STEPPER MOTOR

CARATTERISTICHE GENERALI - GENERAL FEATURES



- **DOSAGGIO ACCURATO**
- Equipaggiata con motore stepper
- performance fino a 10 l/h e 6 bar
- Firmware specifico per micro dosaggio
- Adatta a prodotti chimici che sviluppano gas
- **MOTORE STEPPER**
- Funzionamento accurato e bassa rumorosità < 35 db
- Accoppiamento diretto
- **TUBI**
- vasta gamma di tubi per specifiche applicazioni
- **MODELLO MULTIFUNZIONE**
- 6 configurazioni differenti: Manuale, mA, PPM, 1:N, N:1, Batch
- **MODELLO CONDUCIBILITA'**
- La pompa NIKE CR ha un controller di conducibilità integrato con 2 differenti configurazioni
Manuale (dosaggio costante)
Range 100 ÷ 15000 µS con 1% di accuratezza
Sonda di conducibilità K1 (C1)
- **KIT INSTALLAZIONE**
- Filtro di fondo, valvola di iniezione, tubi di collegamento supporto a muro inclusi

MODELLO CT

- Range misura conducibilità: 0÷15 mS (±0,1 mS)
- Relay 250V 8A (Contatto secco) apre/chiude la valvola di scarico
- Alimentazione 100÷240 Vac
- Input segnale frequenza
- Flusso di dosaggio proporzionale 10 L/H at 2 Bar
- Tubo peristaltico PharMED
- Allarme di rottura tubo
- Involucro IP65

- **ACCURATE DOSING**
- equipped with stepper motor technology
- performances up to 10 l/h and up to 6 bar
- special firmware for micro dosing
- suitable for dosing gas producing chemicals
- **STEPPER MOTOR**
- accurate reliable and ultra quiet <35 db
- direct coupling
- **TUBING**
- big range of special tubing for specific applications
- **MULTIFUNCTION MODEL**
- 6 different configurations: Manual, mA, PPM, 1:N, N:1, Batch
- **CONDUCTIVITY MODEL**
- Nike CR pump has conductivity controller integrated with 2 different configurations
Manual mode (constant dosing)
Conductivity Mode (Set-point dosing)
Range 100 ÷ 15000 µS with 1% accuracy
Conductivity probe k1 (C1)
- **INSTALLATION KIT**
- Including foot filter, injection valve, tubes, screws and base mounting support

CT MODEL

- Conductivity measure range: 0÷15 mS (±0,1 mS Accuracy)
- Relay 250V 8A (Dry contact) open/close drain valve
- Power Supply 100÷240 Vac
- Frequency input signal
- Proportional dosing flowrate 10 L/H at 2 Bar
- Peristaltic Tube PharMED
- Tube failure alarm
- IP65 Enclosure box

TECHNICAL FEATURES

MODELS	NOMINAL PRESSURE	DELIVERY RATE	MINIMUM DELIVERY RATE	TUBING	TUBING INTERNAL DIAMETER
NIKE 50 FM10	2 bar	10 l/h	10 ml/h	Pharmed®	6 mm
NIKE 50 FM02	3 bar	2 l/h	2 ml/h	B wall	3 mm
NIKE 50 CR10	2 bar	10 l/h	10 ml/h	Pharmed	6 mm
NIKE 50cc FM02H	6 bar	2 l/h	2 ml/h	Gore®	6 mm
NIKE 50cc FM08H	3 bar	8 l/h	8 ml/h	Gore®	3 mm
NIKE 50tt FM02T	3 bar	2 l/h	2 ml/h	Tygon F4040®	3 mm
NIKE 50 FM15	0 bar	15 l/h	15 ml/h	Santoprene®	6 mm
NIKE 50 FM15	0,1 bar	25 l/h	25 ml/h	Santoprene	6 mm

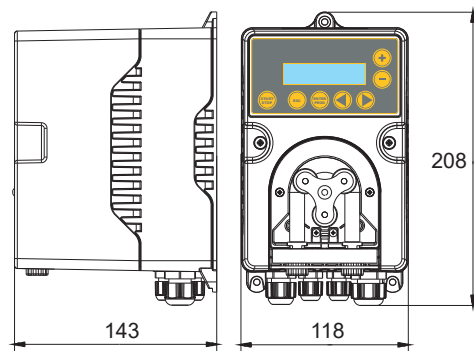



WATER TREATMENT DIVISION TAURUS SERIES

POMPE DOSATRICI ELECTROMECCANICHE ELECTROMECHANIC DOSING PUMPS



CARATTERISTICHE GENERALI GENERAL FEATURES



- IL MECCANISMO DI QUESTE POMPE È DEL TIPO AD ECCENTRICO E PIATTELLO CON RITORNO A MOLLA, RACCHIUSO DA UN CARTER DI ALLUMINIO IN BAGNO D'OLIO
- DI SERIE LA REGOLAZIONE DELLA POMPA È MANUALE MA È POSSIBILE COMANDARLA CON UN SEGNALE REMOTO, TRAMITE SERVOCOMANDO ELETTRICO CON UN SEGNALE 4÷20 mA O INVERTER
- THESE PUMPS ARE PLUNGER PISTON METERING PUMPS FEATURING A SPRING RETURN STROKE IN AN ALLUMINIUM HOUSING WITH OIL BATH
- EACH PUMP IS EQUIPPED WITH MANUAL FLOW ADJUSTMENT AND CAN BE EQUIPPED WITH AN ELECTRIC ACTUATOR WHICH ACCEPTS A 4÷20 mA OR INVERTER

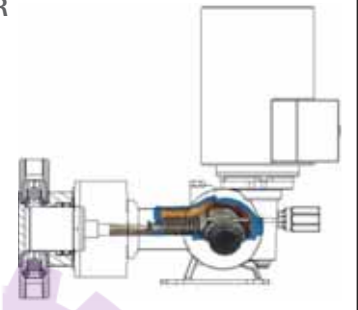

PISTON VERSION

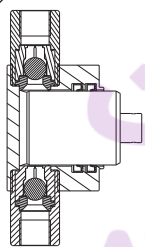

- TESTATA POMPANTE DI SERIE IN AISI316 o in PVC • PISTONE IN AISI316 o CERAMICA
- SS316 or PVC PUMP HEAD • SS316 or CERAMIC PISTON

DIAPHRAGM VERSION

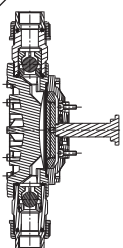

- TESTATA POMPANTE DI SERIE IN AISI316, PP, PVDF e PVC • MEMBRANA IN PTFE
- SS316, PP, PVDF or PVC PUMP HEAD • PTFE DIAPHRAGM

آتور صنعت
ATOORSANAT



MODELLI MODELS

TP.15 PISTON VERSION

- **CORSA 15 mm**

- portate max 1,5÷304 lt/h ● pressione max 20 bar ● frequenza fissa 58-78-116 colpi/min ● diametri pistone 6÷24 mm ● motori 0,18/0,25 kW di tipo unificato IP55

- **STROKE 15 mm**

- 1,5÷304 lt/h max flow rate ● 20 bar max pressure ● 58-78-116 fixed frequency ● 6÷24 piston diameters ● 0,18/0,25 kW standard IP55 motors

TP.25 PISTON VERSION

- **CORSA 25 mm**

- portate max 40÷1000 lt/h ● pressione max 20 bar ● frequenza fissa 58-78-116 colpi/min ● diametri pistone 25÷89 mm ● motori 0,25/0,37/0,55/0,75 kW di tipo unificato IP55

- **STROKE 25 mm**

- 40÷1000 lt/h max flow rate ● 20 bar max pressure ● 58-78-116 fixed frequency ● 6÷24 piston diameters ● 0,25/0,37/0,55/0,75 kW standard IP55 motors

TM.2-4-6 DIRECT DIAPHRAGM VERSION

- **CORSA 2-4-6 mm**

- portate max 5,5÷460 lt/h ● pressione max 10 bar ● frequenza fissa 58-78-116 colpi/min ● diametri membrana 65÷165 mm ● motori 0,18/0,25/0,37 kW di tipo unificato IP55

- **STROKE 2-4-6 mm**

- 5,5÷460 lt/h max flow rate ● 10 bar max pressure ● 58-78-116 fixed frequency ● 65÷165 diaphragm diameters ● 0,18/0,25/0,37 kW standard IP55 motors

TM.5 DIRECT DIAPHRAGM VERSION

- **CORSA di RITORNO A MOLLA e CORPO RIDUTTORE IN PP**

- portate max 17÷60 lt/h ● pressione max 5 bar ● frequenza fissa 41-58-82-116-160 colpi/min ● diametro membrana 50 mm ● motore 0,9 kW di tipo unificato IP55

- **SPRING RETURN MECHANISM in a PP HOUSING**

- 17÷60 lt/h max flow rate ● 5 bar max pressure ● 41-58-82-116-160 fixed frequency ● 50 piston diameter ● 0,9 kW standard IP55 motor

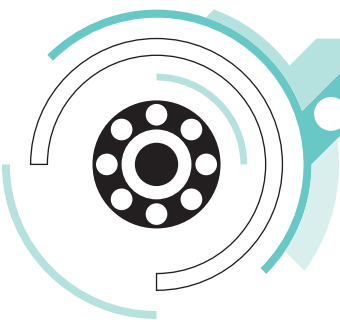



CARATTERISTICHE GENERALI GENERAL FEATURES



TP/TM.INV

• **POMPE DOSATRICI PISTONE / MEMBRANA INVERTER INCORPORATO**

- Testata Pompante di serie in AISI316 e PVC (TAP), AISI e PP (TAM)
- La Tenuta sul Pistone è del tipo automatico a labbro
- Temperatura max di dosaggio 90°C (AISI), 40°C (PP)
- Di serie la Regolazione della Pompa è manuale ma è possibile comandarla con un Segnale Remoto, tramite Servocomando Elettrico con un segnale 4÷20 mA

• **PISTON/DIAPHRAGM DOSING PUMPS WITH ASSEMBLED INVERTER**

- SS316 and PVC (TAP), SS316 and PP (TAM) pump head
- Piston Seal is lip automatic type
- Max Dosing Temperature 90°C (SS), 40°C (PP)
- As standard the Pump can be Regulated Manually but it can also be coupled to a Remote Signal, through an Electrical Servo-control with 4÷20 mA signal

آتور صنعت
ATOORSANAT

MOTORE MOTOR



- motore asincrono trifase, protezione IP54, servoventilazione assiale IC06. Modulo Inverter, premontato a bordo motore, ALTAIR-M037, versione "/B", 1 ingresso analogico 4÷20 mA, 4 ingressi digitali, seriale RS485 di programmazione e taratura

- Asynchronous three-phase motor, IP54 protection, axial servo-venting IC06. Inverter module, pre-installed, ALTAIR-M037 motor, "/B" version, 1 analogic input, 4÷20 mA, 4 digital inputs, 1 serial RS485 input for programming and calibration

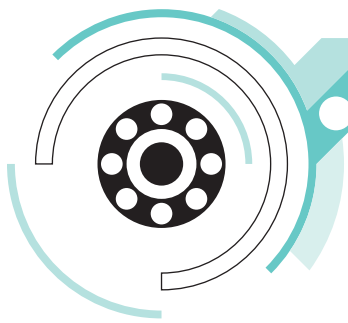

ESEMPLI DI INSTALLAZIONE - INSTALLATION EXAMPLES

- Controllo misura e dosaggio proporzionale mediante pompa con Inverter ad un convertitore elettromagnetico di portata o ad un segnale contatore lancia impulsi
- Flow measure through electromagnetic flow rate or signal from pulse emitter water meter and proportional dosing with motor pump with inverter

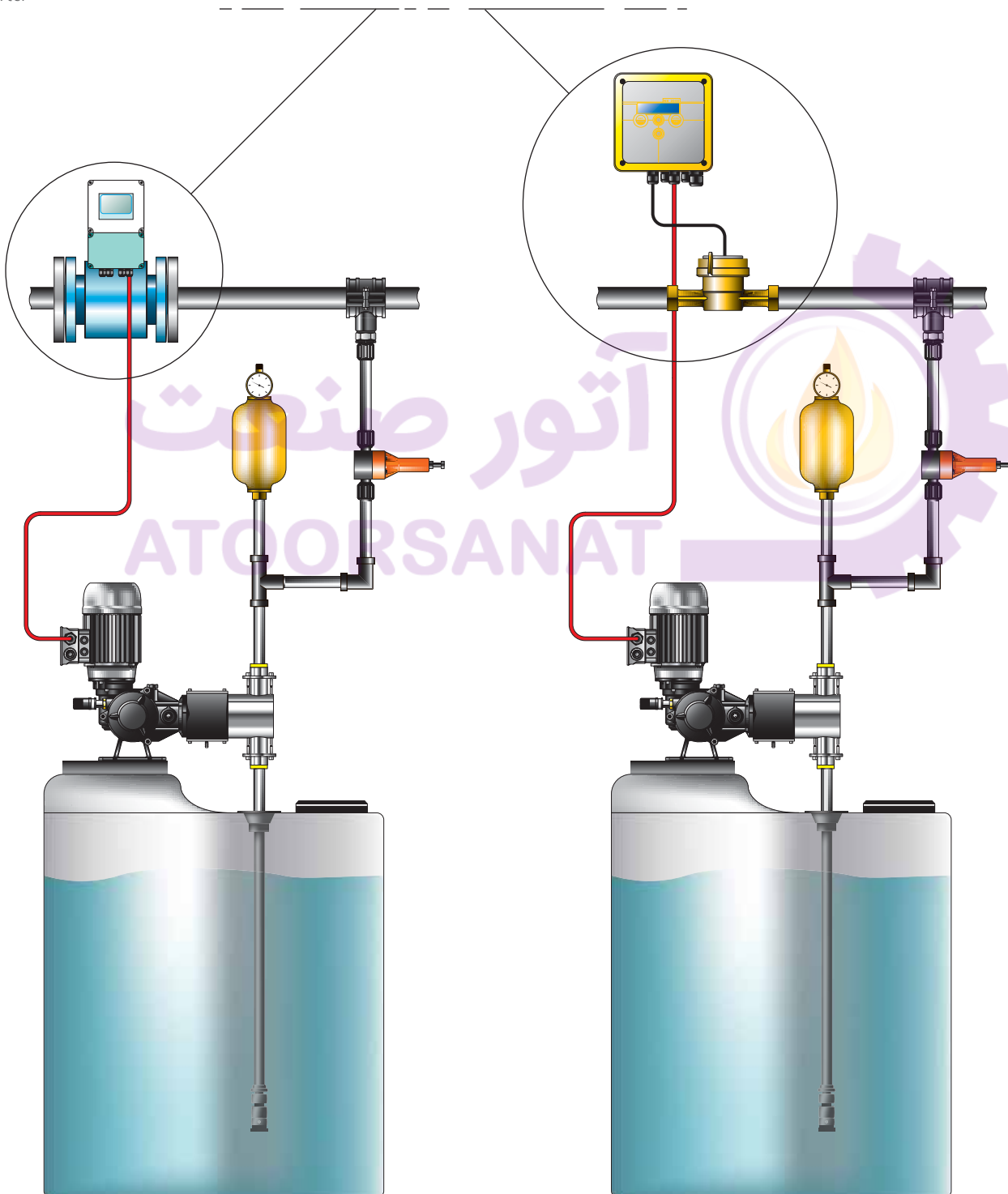



WATER TREATMENT DIVISION TAURUS SERIES



POMPE DOSATRICI ELECTROMECCANICHE ELECTROMECHANIC DOSING PUMPS

CARATTERISTICHE TECNICHE TECHNICAL FEATURES

TP.15 PISTON VERSION

MODELLI MODELS	Ø PISTONI Ø PISTONS	COLPI/min. STROKES/min	PORTATE FLOW RATES	PRESSIONI PRESSURES		CONNESSIONI CONNECTIONS	PESI WEIGHTS	
				SS316	PVC		SS316	PVC
TRIFASE THREE-PHASE 0,18kW - MONOFASE SINGLE-PHASE 0,25 kW								
TP15006A	6 mm	58	1,5 lt/h	20 bar	10 bar	1/4" g.f.	9,8 kg	8,4 kg
TP15006C	6 mm	116	3,0 lt/h	20 bar	10 bar	1/4" g.f.	9,8 kg	8,4 kg
TP15011A	11 mm	58	5,0 lt/h	20 bar	10 bar	1/4" g.f.	9,8 kg	8,4 kg
TP15011C	11 mm	116	10,0 lt/h	20 bar	10 bar	1/4" g.f.	9,8 kg	8,4 kg
TP15017A	17 mm	58	11,0 lt/h	20 bar	10 bar	3/8" g.f.	9,8 kg	8,4 kg
TP15017C	17 mm	116	22,0 lt/h	20 bar	10 bar	3/8" g.f.	9,8 kg	8,4 kg
TP15025A	25 mm	58	25,0 lt/h	20 bar	10 bar	3/8" g.f.	9,8 kg	8,4 kg
TP15025C	25 mm	116	50,0 lt/h	20 bar	10 bar	3/8" g.f.	9,8 kg	8,4 kg

TRIFASE THREE-PHASE 0,25kW - MONOFASE SINGLE-PHASE 0,37 kW								
TP15030A	30 mm	58	35,0 lt/h	20 bar	10 bar	3/8" g.f.	11,2 kg	9,8 kg
TP15030C	30 mm	116	70,0 lt/h	20 bar	10 bar	3/8" g.f.	11,2 kg	9,8 kg
TP15038A	38 mm	58	55,0 lt/h	17 bar	10 bar	3/8" g.f.	12,8 kg	10 kg
TP15038C	38 mm	116	110,0 lt/h	17 bar	10 bar	3/8" g.f.	12,8 kg	10 kg
TP15048A	48 mm	58	85,0 lt/h	10 bar	10 bar	1/2" g.f.	12,8 kg	10 kg
TP15048C	48 mm	116	170,0 lt/h	10 bar	10 bar	1/2" g.f.	12,8 kg	10 kg
TP15054A	54 mm	58	110,0 lt/h	8 bar	8 bar	1/2" g.f.	14,6 kg	10,3 kg
TP15054C	54 mm	116	220,0 lt/h	8 bar	8 bar	1/2" g.f.	14,6 kg	10,3 kg
TP15064A	64 mm	58	152,0 lt/h	6 bar	6 bar	3/4" g.f.	15,7 kg	10,5 kg
TP15064C	64 mm	116	304,0 lt/h	6 bar	6 bar	3/4" g.f.	15,7 kg	10,5 kg

ATOORSANAT

ESECIZIONI SPECIALI CORPI POMPA PVC PER ALTE PRESSIONI PVC PUMP HEAD SPECIAL EXECUTIONS FOR HIGH PRESSURES

PRESSIONE PRESSURE	Ø PISTONE Ø PISTON
20 bar	11 - 17 - 25 - 30 - 38 mm

DATI DIMENSIONALI DIMENSIONAL FEATURES

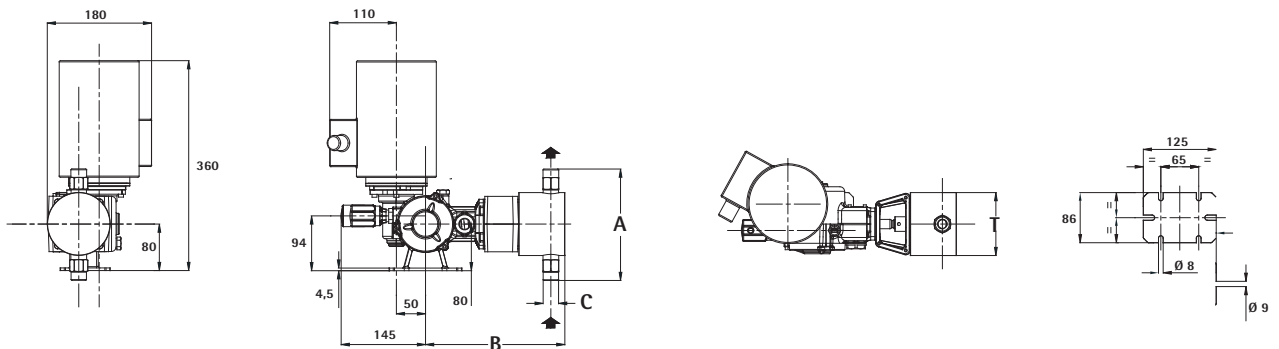

Ø PISTONI Ø PISTONS	SS316				PVC			
	A	B	C	T	A	B	C	T
6 mm	120	210	1/4" g.f.	68	157	216	1/4" g.f.	80
11 mm	120	210	1/4" g.f.	68	157	216	1/4" g.f.	80
17 mm	120	210	3/8" g.f.	68	147	216	3/8" g.f.	80
25 mm	120	215	3/8" g.f.	68	147	225	3/8" g.f.	80
30 mm	120	215	3/8" g.f.	68	147	225	3/8" g.f.	80
38 mm	160	227	3/8" g.f.	88	168	235	3/8" g.f.	100
48 mm	160	227	1/2" g.f.	88	196	240	1/2" g.f.	100
54 mm	173	229	1/2" g.f.	108	216	240	1/2" g.f.	120
64 mm	202	238	3/4" g.f.	108	222	250	3/4" g.f.	120



WATER TREATMENT DIVISION TAURUS SERIES

POMPE DOSATRICI ELECTROMECCANICHE ELECTROMECHANIC DOSING PUMPS



CARATTERISTICHE TECNICHE TECHNICAL FEATURES

TM.2-4-6 DIAPHRAGM VERSION

MODELLI MODELS	Ø MEMBRANA Ø DIAPHRAGM	L.CORSA L.STROKE	COLPI/min. STROKES/min	PORTATE FLOW RATES	PRESSIONI PRESSURES	CONNESSIONI CONNECTIONS	PESI WEIGHTS SS316	PVC/PP/PVDF
TRIFASE THREE-PHASE 0,18kW - MONOFASE SINGLE-PHASE 0,25 kW								
TM02064A	64 mm	2 mm	58	5,5 lt/h	10 bar	1/4" g.f.	10,2 kg	8,5 kg
TM02064B	64 mm	2 mm	78	8,0 lt/h	10 bar	1/4" g.f.	10,2 kg	8,5 kg
TM02064C	64 mm	2 mm	116	11,0 lt/h	10 bar	1/4" g.f.	10,2 kg	8,5 kg
TRIFASE THREE-PHASE 0,25kW - MONOFASE SINGLE-PHASE 0,37 kW								
TM02094A	94 mm	2 mm	58	20,0 lt/h	10 bar	3/8" g.f.	10,7 kg	8,4 kg
TM02094B	94 mm	2 mm	78	26,0 lt/h	10 bar	3/8" g.f.	10,7 kg	8,4 kg
TM02094C	94 mm	2 mm	116	40,0 lt/h	10 bar	3/8" g.f.	10,7 kg	8,4 kg
TRIFASE THREE-PHASE 0,37kW - MONOFASE SINGLE-PHASE 0,55 kW								
TM04108A	108 mm	4 mm	58	60,0 lt/h	10 bar	3/8" g.f.	13,3 kg	10,1 kg
TM04108B	108 mm	4 mm	78	80,0 lt/h	10 bar	3/8" g.f.	13,3 kg	10,1 kg
TM04108C	108 mm	4 mm	116	120,0 lt/h	10 bar	3/8" g.f.	13,3 kg	10,1 kg
TM06138A	138 mm	6 mm	58	155,0 lt/h	7 bar	3/4" g.f.	18,4 kg	12,3 kg
TM06138B	138 mm	6 mm	78	220,0 lt/h	7 bar	3/4" g.f.	18,4 kg	12,3 kg
TM06138C	138 mm	6 mm	116	310,0 lt/h	7 bar	1" g.f.	18,4 kg	12,3 kg
TM06165A	165 mm	6 mm	58	230,0 lt/h	5 bar	1" g.f.	22,0 kg	13,2 kg
TM06165B	165 mm	6 mm	78	330,0 lt/h	5 bar	1" g.f.	22,0 kg	13,2 kg
TM06165C	165 mm	6 mm	116	460,0 lt/h	5 bar	1" g.f.	22,0 kg	13,2 kg

TRIFASE THREE-PHASE 1,1kW								
TMP1	210 mm	10-20mm	93/116	800,0 to 2000,0 lt/h	5 bar	DN50-PN10 RF	30,0 kg	20,0 kg

ESECUZIONI SPECIALI CORPI POMPA PVC PER ALTE PRESSIONI PVC PUMP HEAD SPECIAL EXECUTIONS FOR HIGH PRESSURES

PRESSIONE PRESSURE	Ø PISTONE Ø PISTON
16 bar	64 - 94 mm

DATI DIMENSIONALI DIMENSIONAL FEATURES

TM

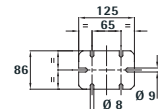
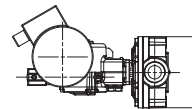
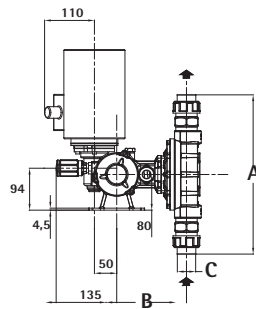
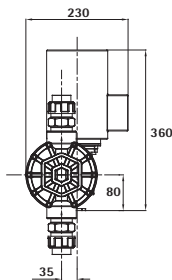

Ø MEMBRANA Ø DIAPHRAGM	SS316				PVC/PP/PVDF			
	A	B	C	T	A	B	C	T
65 mm	208	149	1/4" g.f.	98	150	144	1/4" g.f.	98
94 mm	236	144	3/8" g.f.	117	172	146	3/8" g.f.	120
108 mm	248	144	3/8" g.f.	131	212	146	3/8" g.f.	140
138 mm	347	158	3/4" g.f. - 1" g.f.	160	258	157	3/8" g.f. - 1" g.f.	170
165 mm	377	160	1" g.f.	193	296	157	1" g.f.	190

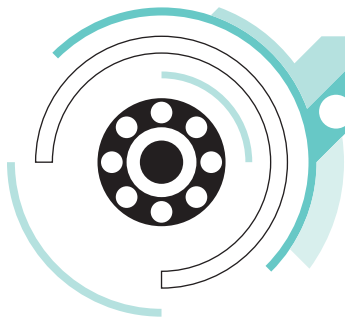

TMP1

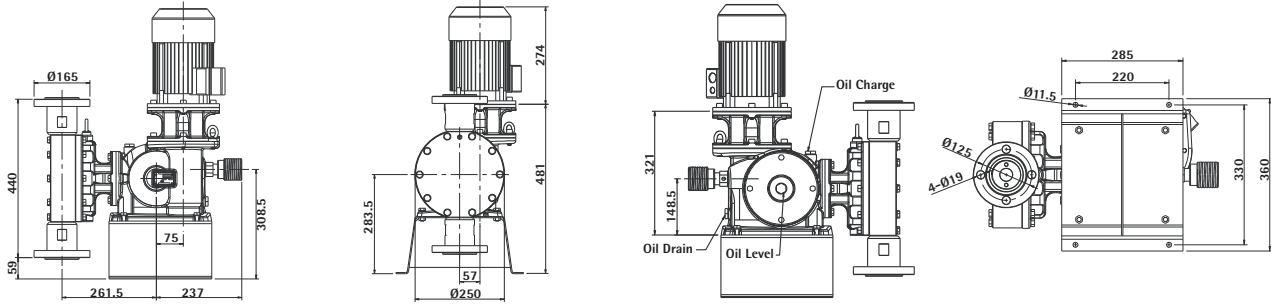

CARATTERISTICHE TECNICHE TECHNICAL FEATURES

TM.5 DIAPHRAGM VERSION

MODELLI MODELS	Ø MEMBRANA Ø DIAPHRAGM	COLPI/min. STROKES/min	PORTATE FLOW RATES	PRESSIONI	PRESSURES	CONNESSIONI	CONNECTIONS	PESI WEIGHTS	
				bar	psi	SS316	PVC	SS316	PVC/PP
TRIFASE THREE-PHASE 0,09kW									
TM05050E	50 mm	41	15,0 lt/h	5	72,5	1/2" g.m.	3/4" g.m.	5,3 kg	4,5 kg
TM05050A	50 mm	58	20,0 lt/h	5	72,5	1/2" g.m.	3/4" g.m.	5,3 kg	4,5 kg
TM05050F	50 mm	82	30,0 lt/h	5	72,5	1/2" g.m.	3/4" g.m.	5,3 kg	4,5 kg
TM05050C	50 mm	116	42,0 lt/h	5	72,5	1/2" g.m.	3/4" g.m.	5,3 kg	4,5 kg
TM05050G	50 mm	164	60,0 lt/h	5	72,5	1/2" g.m.	3/4" g.m.	5,3 kg	4,5 kg

Disponibile la versione MONOFASE a max 1 bar
SINGLEPHASE version available at max 1 bar

DATI DIMENSIONALI DIMENSIONAL FEATURES

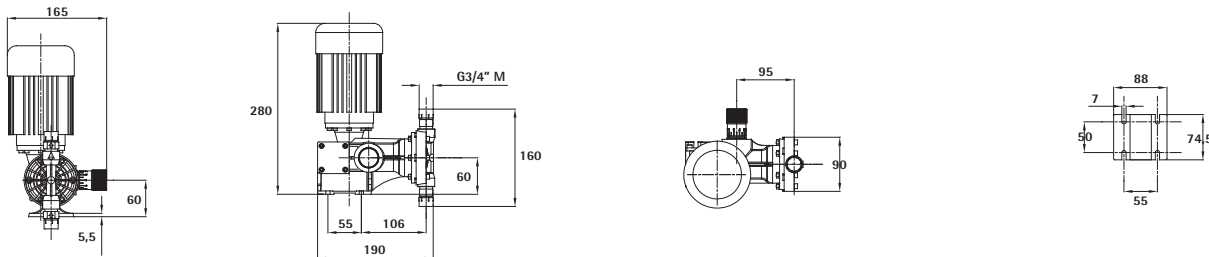



CARATTERISTICHE GENERALI GENERAL FEATURES



POMPE DOSATRICI PISTONE/MEMBRANA 12VDC

• al fine di soddisfare le esigenze di alimentazione delle nostre pompe in quelle condizioni dove non è possibile utilizzare la normale rete elettrica facendo ricorso all'utilizzo di batterie o pannelli solari, completiamo la gamma con una serie di modelli equipaggiati da motore alimentato a 12 VDC

12VDC PISTON/DIAPHRAGM DOSING PUMPS

• in order to meet the power needs of our pumps in those conditions where you can not use the normal power by resorting to the use of batteries or solar panels, we complete the range with a series of models equipped with engine running to 12 VDC

CARATTERISTICHE TECNICHE TECHNICAL FEATURES

TP.15 12VDC PISTON VERSION

MODELLI MODELS	Ø PISTONI Ø PISTONS	COLPI/min. STROKES/min		PORTATE FLOW RATES		PRESSIONI PRESSURES		CONNESSIONI CONNECTIONS	
		SS316	PVC	SS316	PVC	SS316	PVC	SS316	PVC
12 VDC (KW) 0,37 kW (IP55)									
TP15025A	25 mm	84	85	34 lt/h	36 lt/h	20 bar	10 bar	3/8" g.f.	3/8" g.f.
TP15025C	25 mm	140	145	60 lt/h	62 lt/h	20 bar	10 bar	3/8" g.f.	3/8" g.f.
TP15030A	30 mm	72	72	40 lt/h	40 lt/h	20 bar	10 bar	3/8" g.f.	3/8" g.f.
TP15030C	30 mm	140	140	78 lt/h	78 lt/h	20 bar	10 bar	3/8" g.f.	3/8" g.f.
TP15038A	38 mm	68	68	60 lt/h	60 lt/h	17 bar	10 bar	3/8" g.f.	3/8" g.f.
TP15038C	38 mm	128	130	114 lt/h	118 lt/h	17 bar	10 bar	3/8" g.f.	3/8" g.f.
TP15048A	48 mm	72	72	100 lt/h	100 lt/h	10 bar	10 bar	1/2" g.f.	1/2" g.f.
TP15048C	48 mm	140	140	190 lt/h	190 lt/h	10 bar	10 bar	1/2" g.f.	1/2" g.f.
TP15054A	54 mm	72	72	140 lt/h	140 lt/h	8 bar	8 bar	1/2" g.f.	1/2" g.f.
TP15064C	54 mm	140	140	270 lt/h	270 lt/h	8 bar	8 bar	1/2" g.f.	1/2" g.f.
TP15064A	64 mm	76	74	180 lt/h	185 lt/h	6 bar	4 bar	3/4" g.f.	3/4" g.f.
TP15064C	64 mm	140	142	350 lt/h	360 lt/h	6 bar	4 bar	3/4" g.f.	3/4" g.f.

TM.2-4-6 12VDC DIAPHRAGM VERSION

MODELLI MODELS	Ø MEMBRANA Ø DIAPHRAGM	COLPI/min. STROKES/min		PORTATE FLOW RATES		PRESSIONI PRESSURES		CONNESSIONI CONNECTIONS	
		SS316	PP/PVC	SS316	PP/PVC	SS316	PP/PVC	SS316	PP/PVC
12 VDC (KW) 0,37 kW (IP55)									
TM02094A	94 mm	72	72	23 lt/h	24 lt/h	16 bar	10 bar	3/8" g.f.	3/8" g.f.
TM02094B	94 mm	90	90	30 lt/h	31 lt/h	16 bar	10 bar	3/8" g.f.	3/8" g.f.
TM02094C	94 mm	144	145	45 lt/h	46 lt/h	16 bar	10 bar	3/8" g.f.	3/8" g.f.

12 VDC (KW) 0,37 kW (IP55)									
TM04108A	108 mm	72	72	65 lt/h	65 lt/h	10 bar	10 bar	3/8" g.f.	3/8" g.f.
TM04108B	108 mm	92	92	90 lt/h	90 lt/h	10 bar	10 bar	3/8" g.f.	3/8" g.f.
TM06108C	108 mm	140	140	120 lt/h	120 lt/h	10 bar	10 bar	3/8" g.f.	3/8" g.f.
TM06138A	138 mm	72	72	200 lt/h	200 lt/h	7 bar	7 bar	3/8" g.f.	3/8" g.f.
TM06138B	138 mm	92	92	250 lt/h	250 lt/h	7 bar	7 bar	3/8" g.f.	3/8" g.f.
TM06138C	138 mm	140	140	390 lt/h	390 lt/h	7 bar	7 bar	1" g.f.	1" g.f.
TM06165A	165 mm	70	70	300 lt/h	300 lt/h	5 bar	5 bar	1/2" g.f.	1/2" g.f.
TM06165B	165 mm	95	95	380 lt/h	380 lt/h	5 bar	5 bar	1/2" g.f.	1/2" g.f.
TM06165C	165 mm	135	136	620 lt/h	620 lt/h	3 bar	3 bar	1/2" g.f.	1/2" g.f.



ELECTROMECHANIC PRODUCTS DOSING UNITS SERIES

CARATTERISTICHE GENERALI GENERAL FEATURES



DP.200

● GRUPPO DI DOSAGGIO COMPOSTO DA:

- pompa TAURUS (TAP/TAM)
- serbatoio 200, 300, 500, 1000 lt
- supporto in PVC
- kit accessori completo

● DOSING UNIT COMPOSED BY

- TAURUS pump
- 200, 300, 500, 1000 lt tank
- PVC support
- complete accessories kit

آتور صنعت
ATOORSANAT

CARATTERISTICHE GENERALI GENERAL FEATURES



DPM.200

● GRUPPO DI DOSAGGIO COMPOSTO DA:

- pompa TAURUS (TAP/TAM)
- serbatoio 200, 300, 500, 1000 lt
- supporto in PVC
- agitatore MIX.1 T
- gruppo aspirazione AC.LA
- kit accessori completo

● DOSING UNIT COMPOSED BY

- TAURUS pump
- 200, 300, 500, 1000 lt tank
- PVC support
- mixer MIX.T 1
- suction group AC.LA
- complete accessories kit



ACCESSORISTICA - ACCESSORIES

- **VALVOLE DI SICUREZZA:** UTILIZZATE PER EVITARE ANOMALE SOVRA PRESSIONI ALLA POMPA E NELLE TUBAZIONI. LE POMPE DOSATRICI SONO POMPE VOLUMETRICHE CHE POSSONO RAGGIUNGERE ELEVATE PRESSIONI IN UNA CORSA, ESSE DEVONO PERTANTO ESSERE PROTETTE DA POSSIBILI OCCLUSIONI DELLE LINEE DI SCARICO PROVOCATE DA SEDIMENTAZIONI O DALL'ACCIDENTALE CHIUSURA DI UNA VALVOLA DI INTERCETTAZIONE. LE POMPE A MEMBRANA IDRAULICA SONO PROTETTE DA UNA VALVOLA LIMITATRICE DI PRESSIONE INTEGRATA NEL CIRCUITO IDRAULICO, PER PROTEGGERE L'IMPIANTO È NECESSARIO INSTALLARE UNA VALVOLA DI SICUREZZA SULLA LINEA DI MANDATA
- **VALVOLE DI CONTROPRESSIONE:** PER IL CORRETTO FUNZIONAMENTO DI UNA POMPA DOSATRICE E PER EVITARE IL PASSAGGIO SPONTANEO DI LIQUIDO (SIFONAMENTO) È NECESSARIO CHE LA PRESSIONE DI ASPIRAZIONE SIA MINORE DELLA PRESSIONE DI SCARICO; QUALORA QUESTA CONDIZIONE NON FOSSE RISPETTATA NELL'IMPIANTO, INSTALLARE UNA VALVOLA DI CONTROPRESSIONE
- **POLMONI SMORZATORI:** IL MOTO ALTERNATIVO DEL PISTONE DELLE POMPE DOSATRICI GENERA PULSAZIONI: AD OGNI CORSA, LA COLONNA DI LIQUIDO DELLE LINEE DI ASPIRAZIONE E DI MANDATA È ACCELERATA DA ZERO ALLA MASSIMA VELOCITÀ POI DECELERATA FINO ALLO ZERO. I POLMONI SMORZATORI SONO GLI ACCESSORI CONSIGLIATI PER RIDURRE ELEVATE E NON AMMISSIBILI FLUTTUAZIONI DI PRESSIONE O PER RENDERE PIÙ LINEARE IL FLUSSO. ANALOGO RISULTATO PUÒ ESSERE OTTENUTO CON L'IMPIEGO DI UN GRUPPO DI DOSAGGIO A TESTE MULTIPLE CON COSTI SUPERIORI
- **PRESSURE SAFETY VALVES:** ARE INSTALLED TO PREVENT DANGEROUS SITUATIONS IN CASE OF UNEXPECTED OVERPRESSURE THAT CAN DAMAGE THE PUMP AND THE PIPES. METERING PUMPS CAN REACH HIGH PRESSURES IN ONE STROKE, THEREFORE THEY SHOULD BE PROTECTED BY POSSIBLE CLOGGING OF THE PIPE CAUSED, FOR INSTANCE, BY ACCIDENTAL CLOSURE OF VALVE. HYDRAULIC SANDWICH DIAPHRAGM PUMP ARE PROTECTED WITH A LIMITING PRESSURE VALVE BUILT-IN IN THE HYDRAULIC CIRCUIT, THE PITTING SHOULD BE PROTECTED BY IN-LINE PRESSURE SAFETY VALVE. ON REQUEST PSV MAY BE SUPPLIED WITH PED CERTIFICATE
- **BACK PRESSURE VALVES:** TO ALLOW THE CORRECT OPERATION OF A PUMP AND TO PREVENT THE FLOW-THROUGH (SIPHONING) OF THE PROCESS LIQUID, THE DISCHARGE PRESSURE SHOULD BE GREATER THAN THE SUCTION PRESSURE; WHEN THIS CONDITION IS NOT RESPECTED THEN A BACKPRESSURE VALVE CAN BE THE SOLUTION
- **PULSATION BAG:** THE RECIPROCATING MOVEMENT OF THE PISTON GENERATES PULSATIONS: DURING EACH STROKE THE LIQUID CONTAINED IN THE SUCTION AND DISCHARGE LINES IS ACCELERATED FROM ZERO TO THE MAXIMUM SPEED AND THEN DECELERATED TO ZERO AGAIN. PULSATION DAMPERS ARE THE SUGGESTED ACCESSORIES TO REDUCE HIGH AND UNWANTED DANGEROUS PRESSURE FLUCTUATIONS OR TO OBTAIN A LINEARITY OF THE FLOW

VS



- valvole di sicurezza (AISI/PTFE)
- safety valves (SS316/PTFE)

MODELLI MODELS	PORTATE FLOW RATES	PRESSIONI PRESSURES		CONNESSIONI CONNECTIONS
		min	max	
VS.1 S	250 lt/h	0 bar	19 bar	1/2" g.f.
	250 lt/h	20 bar	45 bar	1/2" g.f.
	250 lt/h	46 bar	150 bar	1/2" g.f.
VS.2 S	650 lt/h	0 bar	13 bar	3/4" g.f.
	650 lt/h	14 bar	30 bar	3/4" g.f.
	650 lt/h	31 bar	100 bar	3/4" g.f.

VS.R



- valvole di sicurezza regolabili (AISI/PTFE)
- Adjustable safety valves (SS316/PTFE)

MODELLI MODELS	PORTATE FLOW RATES	PRESSIONI PRESSURES		CONNESSIONI CONNECTIONS
		min	max	
VS.R S (AISI/PVC)	300 lt/h	0 bar	5 bar	3/8" g.f.
	800 lt/h	0 bar	5 bar	3/4" g.f.
	1500 lt/h	0 bar	5 bar	1" g.f.

VZX.S



- valvole di contropressione (AISI/PTFE)
- back-pressure valves (SS316/PTFE)

MODELLI MODELS	PORTATE FLOW RATES	PRESSIONI PRESSURES	CONNESSIONI CONNECTIONS
100 lt/h	2 bar	1/4" f	
200 lt/h	2 bar	3/4" f	
420 lt/h	2 bar	1/2" f	
800 lt/h	2 bar	3/4" f	
1650 lt/h	2 bar	1" f	



ACCESSORISTICA - ACCESSORIES

VS.M

- valvole di contropressione regolabili (AISI/PTFE)
- Adjustable back-pressure valves (SS316/PTFE)

MODELLI MODELS	PORTATE FLOW RATES	PRESSIONI PRESSURES		CONNESSIONI CONNECTIONS
		min	max	
VS.MS (AISI/PVC)	300 lt	0 bar	5 bar	3/8" g.f.
	800 lt	0 bar	5 bar	3/4" g.f.
	1500 lt	0 bar	5 bar	1" g.f.

PS.PVC

- polmoni smorzatori
- pulsation bag

CAPACITÀ CAPACITY	PRESSIONI PRESSURES	MATERIALI MATERIALS		CONNESSIONI CONNECTIONS
		body	diaphragm	
0,04 lt	10 bar	PVC	FPM	3/8" g.f.
0,1 lt	10 bar	PVC	FPM	3/8" g.f.
0,35 lt	10 bar	PVC	FPM	1/2" g.f.
0,8 lt	10 bar	PVC	FPM	1/2" g.f.
1,5 lt	10 bar	PVC	FPM	3/4" g.f.
2,3 lt	10 bar	PVC	FPM	3/4" g.f.

PS.AI

- polmoni smorzatori
- pulsation bag

CAPACITÀ CAPACITY	PRESSIONI PRESSURES	MATERIALI MATERIALS		CONNESSIONI CONNECTIONS
		body	diaphragm	
0,01 lt	230 bar	AISI	NBR	3/8" g.f.
0,35 lt	230 bar	AISI	NBR	1/2" g.f.
0,5 lt	230 bar	AISI	NBR	1/2" g.f.
0,8 lt	230 bar	AISI	NBR	1/2" g.f.
1,5 lt	230 bar	AISI	NBR	3/4" g.f.
2,3 lt	230 bar	AISI	NBR	3/4" g.f.

PS.AI 02

- polmoni smorzatori
- pulsation bag

CAPACITÀ CAPACITY	PRESSIONI PRESSURES	MATERIALI MATERIALS		CONNESSIONI CONNECTIONS
		body	diaphragm	
0,5 lt	150 bar	AISI	NBR	3/8" g.f.
0,7 lt	150 bar	AISI	NBR	1/2" g.f.
1 lt	150 bar	AISI	NBR	3/4" g.f.

DP

- dispositivo di precarica
- pressioni 6, 12, 40, 60, 100, 160, 250 bar
- fitting-testing unit
- pressures 6, 12, 40, 60, 100, 160, 250 bar

FY (aisi/pvc)

- filtri di aspirazione
- connessioni 3/8" - 1/2" - 3/4" - 1"
- suction filters
- connections 3/8" - 1/2" - 3/4" - 1"



ACCESSORISTICA ACCESSORIES

AC.FP

- valvole di fondo
- foot valves

CONNESSIONI CONNECTIONS	PORTATE FLOW RATES	MATERIALE MATERIALS	TENUTE SEALS
8/12" g.f.	0÷60,0 lt/h	PVDF-C*	EPDM
8/12" g.f.	0÷60,0 lt/h	PVDF	EPDM

AC.FP

- valvole di fondo
- foot valves

CONNESSIONI CONNECTIONS	PORTATE FLOW RATES		MATERIALE MATERIAL
	min	max	
3/8" g.f.	0÷180,0 lt/h	0÷112,0 lt/h	AISI/PVC
1/2" g.f.	140,0÷365,0 lt/h	90,0÷365,0 lt/h	
3/4" g.f.	250,0÷505,0 lt/h	-	
1" g.f.	365÷1000,0 lt/h	250,0÷505,0 lt/h	

AC.VI

- valvole di iniezione
- injection valves

CONNESSIONI CONNECTIONS	PORTATE FLOW RATES	MATERIALE MATERIAL	TENUTE SEALS
8/12" g.f.	0÷60,0 lt/h	PVDF-C	EPDM
8/12" g.f.	0÷60,0 lt/h	PVDF	EPDM

AC.VI

- valvole di iniezione
- injection valves

CONNESSIONI CONNECTIONS	PORTATE FLOW RATES		MATERIALE MATERIAL
	min	max	
3/8" g.f.	0÷180,0 lt/h	0÷112,0 lt/h	AISI/PVC
1/2" g.f.	140,0÷365,0 lt/h	90,0÷365,0 lt/h	
3/4" g.f.	250,0÷505,0 lt/h	-	
1" g.f.	365÷1000,0 lt/h	250,0÷505,0 lt/h	

AC.VIE

- valvola iniezione estraibile
- valvola iniezione estraibile con intercettatore
- extractable injection valve
- extractable injection valve with ball valve

CONNESSIONI CONNECTIONS	CORPO BODY	TENUTE SEALS
1/2" g.m. IN/OUT	PVC	FPM EPDM



- RACCORDI TUBI FLESSIBILI
- connessioni 3/8"-1/4"-1/2"-1" g.f. / 8x12
- FLEXIBLE TUBING CONNECTIONS
- 3/8"-1/4"-1/2"-1" g.f. / 8x12

*PVDF-C: Miscela di PVC e PVDF. Qualità meccaniche e chimiche superiori al PVC
PVDF-C: PVC and PVDF mixture. Mechanical and chemical properties higher than PVC



ACCESSORISTICA - ACCESSORIES



DIGIDRIVE

- trasduttore di segnale in corrente (4÷20 mA) in valore di frequenza alimentazione motore elettrico
- electronic trasducer from current signal (4÷20 mA) to working frequency of the electric motor

MOTORI MOTORS	ALIMENTAZIONE POWER SUPPLY
up to 0,37 KW singlephase	230 vac (±10%)
up to 0,75 KW singlephase	
up to 0,75 KW threephase	400 vac (±10%)

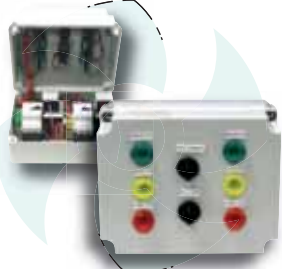

ELECTRIC PANEL

- quadro personalizzato per la gestione di 1 pompa o più pompe a motore e controllo livelli
- customized control panel to operate single pump motors and levels controls

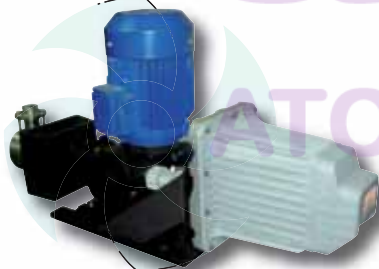

ELECTRIC ACTUATOR

- trasforma una pompa elettromeccanica in una pompa per il dosaggio proporzionale ad un segnale esterno, variandone la corsa, e quindi la portata in maniera automatica
- it allows an electromechanic manual pump to be used as a proportional dosing pump (through external signal), by automatically regulating the stroke lenght and flow rate

CORSA MAX MAX STROKE	25 mm
FORZA MAX MAX FORCE	1300 N
VELOCITÀ MAX MAX SPEED	1 mm/Sec
PRECISIONE ACCURACY	0,6 mm
CONNESSIONE CAVI CABLE CONNECTIONS	2x3/4" NPT UNI6125
OPZIONI OPTIONS	1/2" UNI6125
	1/2" & 3/4" UNI EN ISO 9864
	M 16X1,5
	M 20X1,5
PROTEZIONE PROTECTION	IP65
PESO WEIGHT	6 kg
POTENZA NOMINALE NOMINAL POWER	25 mm
ALIMENTAZIONE PRIMARIA/SECONDARIA PRIMARY/SECONDARY POWER SUPPLY	110÷230 Vac, ±10%, 50/60Hz monofase singlephase
ALIMENTAZIONE AUSILIARIA AUXILIARY POWER SUPPLY	24 VDC (optional)
SEGNALE INGRESSO ANALOGICO ANALOGIC INPUT SIGNAL	standard 4÷20 mA ±1%
	impostabile impostable 20÷20 mA ±1% / 0÷10V ±1% / 1÷50 Hz ±1%
SEGNALE INGRESSO DIGITALE DIGITAL INPUT SIGNAL	0÷5V in frequenza in frequency 0,004÷50 Hz
BANDA MORTA DEAD BAND	2% modificabile modificable
SEGNALE DIGITALE DIGITAL SIGNAL	0÷5 VDC contatto secco dry contact (interruttore remoto remote switch)
SEGNALE CONSENSO ATTUATORE ACTUATOR CONTENT SIGNAL	100÷230 VAC, ±10%
SEGNALE USCITA ANALOGICO ANALOGIC OUTPUT SIGNAL	4÷20 VAC, ±10% F.S. su 500 Ohm (fisso fixed)
USCITA COLLETTORE APERTO OPEN COLLECTOR SIGNAL	24 VDC - 50 mA max
CICLO LAVORO UTILE USEFUL WORKING CYCLE	ciclo a modulazione illimitato no limits modulation cycle



WATER TREATMENT DIVISION NEXUS.1000 SERIES

STRUMENTI DI MISURA E CONTROLLO MEASURING AND CONTROL INSTRUMENTS



CARATTERISTICHE GENERALI GENERAL FEATURES



- **USCITA 4÷20 mA** ideale per collegarsi ad un registratore o ad un sistema di acquisizione dati
- **SCALE DI MISURA SELEZIONABILI** tramite il menu di programmazione è possibile selezionare la scala di misura disponibile, per garantire una versatilità operativa con un unico strumento
- **LO STRUMENTO RICONOSCE LA SOLUZIONE TAMPONE** (pH/Redox) e completa la calibrazione sospendendo il dosaggio (HOLD) ed indicando lo stato di efficienza dell'elettrodo in %
- **MENÙ MULTILINGUA, PROTEZIONE MENÙ, IMPOSTAZIONI TRAMITE PASSWORD, CONTROLLO QUALITÀ DELLA SONDA DI MISURA**

- **OUTPUT 4÷20 mA** ideal solution for connecting to a logger or data acquisition system
- **SELECTABLE MEASUREMENT SCALES** using the programming menu, it is possible to select the available measurement scale to ensure operating versatility with a single instrument
- **INSTRUMENT RECOGNISES THE BUFFER SOLUTION** (pH and Redox) and completes the calibration suspending the dosage (HOLD) and showing the electrode's efficiency in %.
- **MULTILINGUAL MENÙ, PASSWORD PROTECTION FOR SETTING MENÙ, QUALITY INDICATION OF MEASURING PROBES**

آتور صنعت
ATOORSANAT

DISPLAY



- **DISPLAY DIGITALE A LED BLU AD ALTA EFFICIENZA**, a 2 linee di 16 caratteri, permette di visualizzare contemporaneamente 2 parametri: chimica e temperatura
- **DIGITAL DISPLAY WITH HIGH EFFICIENCY BLUE LEDS** with 2 lines of 16 digits per line, allows the contemporaneous visualization of 2 parameters: chemical measure and temperature



CARATTERISTICHE TECNICHE TECHNICAL FEATURES

RANGE	pH - 0÷14,00 (accuratezza accuracy 1%) Rx - ±1000 mV (accuratezza accuracy 1%) CD - 10÷20,000 µS (accuratezza accuracy 1%) sonda probe K10 - 10÷2,000 µS (accuratezza accuracy 1%) sonda probe K5 - 20÷4,000 µS (accuratezza accuracy 1%) sonda probe K1 - 100÷20.000 µS (accuratezza accuracy 1%)
TEMPERATURA TEMPERATURE	0÷100 °C con with PT100 (accuratezza accuracy 1%)
USCITA IN CORRENTE CURRENT OUTPUT	0/4÷20 20÷4/0 mA (±2%)
SET POINT	2 indipendenti attraverso relé di contatto pulito 10A 250V (carico resistivo) 2 independent through 10A 250V dry contact relay (resistance load)

MODELLI MODELS

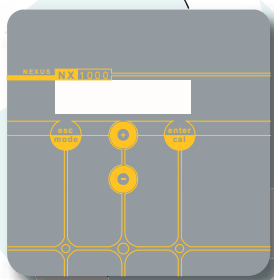

NX.1000 S

- VERSIONE STAGNO
144x144x90 mm
- WATERPROOF VERSION
144x144x90 mm

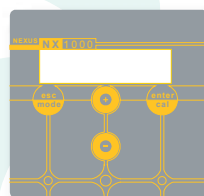

NX.1000 P

- VERSIONE PANNELLO
96x96x92 mm
- PANEL VERSION
96x96x92 mm



NX.1000 DIN

- VERSIONE BARRA DIN RAIL
6 moduli
- WATERPROOF VERSION
6 modules



NX.1000 Q

- VERSIONE PANNELLO
48x96x100 mm
- PANEL VERSION
48x96x100 mm

NX.1500 M

- MULTIPARAMETRICO, VERSIONE STAGNO
234x162x108 mm (IP66)
- MULTIPARAMETER, WATERPROOF VERSION
234x162x108 mm (IP66)



WATER TREATMENT DIVISION NEXUS.2000 SERIES

STRUMENTI DI MISURA E CONTROLLO MEASURING AND CONTROL INSTRUMENTS



CARATTERISTICHE GENERALI GENERAL FEATURES



- **INGRESSO IN TENSIONE (15÷30 VDC)** per congelare la misura **SISTEMA DI CONTROLLO REMOTO (HOLD)**
- **SCALE DI MISURA SELEZIONABILI** tramite il menu di programmazione è possibile selezionare la scala di misura disponibile, per garantire una versatilità operativa con un unico strumento
- **LO STRUMENTO RICONOSCE LA SOLUZIONE TAMPONE** (pH/Redox) e completa la calibrazione sospendendo il dosaggio (HOLD) ed indicando lo stato di efficienza dell'elettrodo in %
- **MENÙ MULTILINGUA, PROTEZIONE MENÙ, IMPOSTAZIONI TRAMITE PASSWORD, CONTROLLO QUALITÀ DELLA SONDA DI MISURA**

- **VOLTAGE INPUT (15÷30 VDC)** for suspending the measurement via **REMOTE CONTROL SYSTEM (HOLD)**
- **SELECTABLE MEASUREMENT SCALES** using the programming menù, it is possible to select the available measurement scale to ensure operating versatility with a single instrument
- **INSTRUMENT RECOGNISES THE BUFFER SOLUTION** (pH and Redox) and completes the calibration suspending the dosage (HOLD) and showing the electrode's efficiency in %.
- **MULTILINGUAL MENÙ, PASSWORD PROTECTION FOR SETTING MENÙ, QUALITY INDICATION OF MEASURING PROBES**

آتور صنعت
ATOORSANAT

DISPLAY



- **DISPLAY DIGITALE A LED BLU AD ALTA EFFICIENZA**, a 2 linee di 16 caratteri, permette di visualizzare contemporaneamente 2 parametri: chimica e temperatura
- **DIGITAL DISPLAY WITH HIGH EFFICIENCY BLUE LEDS** with 2 lines of 16 digits per line, allows the contemporaneous visualization of 2 parameters: chemical measure and temperature



CARATTERISTICHE TECNICHE / TECHNICAL FEATURES

NX2000SERIES RANGE	pH - 0÷14,00 (accuratezza accuracy 1%)
	Rx - ±1000 mV (accuratezza accuracy 1%)
	CD - 10÷20.000 µS (accuratezza accuracy 1%) bassa conducibilità low conductivity 0÷200 µS alta conducibilità high conductivity 0÷50.000 µS
	sonda probe K10 - 10÷2,000 µS (accuratezza accuracy 1%)
	sonda probe K5 - 20÷4,000 µS (accuratezza accuracy 1%)
	sonda probe K1 - 100÷20.000 µS (accuratezza accuracy 1%)
	CL Potentiostatic - 0÷2 / 0÷5 / 0÷10 / 0÷20 / 0÷200 ppm
	FLOW - 0÷9.999.999 (segnale entrata input signal 0,5÷1.500 Hz)
	funzione Batch Batch function conteggio di un volume stabilito calculation of an established volume
	CL Amperometric - 0÷5 ppm
NX2500SERIES RANGE	PR - 0÷14,00 / ±1500 mV
	pH/CD - 0÷14,00 / 0÷20 mS
	pH/CL - 0÷14,00 / 0÷200 ppm
	pH/FLOW - 0÷14,00 / 0÷9.999.999 lt/h
	CD/FLOW - 0÷20 mS / 0÷9.999.999 lt/h
TEMPERATURA TEMPERATURE	0÷100 °C con with PT100 (accuratezza accuracy 1%)
USCITA IN CORRENTE CURRENT OUTPUT	0/4÷20 20÷4/0 mA (±2%) isolata galvanicamente galvanic separation
ALIMENTAZIONE POWER SUPPLY	100÷240 VAC 50/60 Hz
SET POINT	2 indipendenti attraverso relé di contatto pulito 10A 250V (carico resistivo) 2 independent through 10A 250V dry contact relay (resistance load)

MODELLI / MODELS

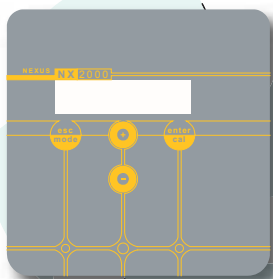

NX.2000 S

- VERSIONE STAGNO
144x144x90 mm
- WATERPROOF VERSION
144x144x90 mm

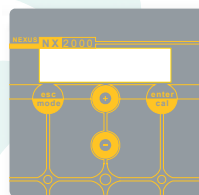

NX.2000 P

- VERSIONE PANNELLO
96x96x92 mm
- PANEL VERSION
96x96x92 mm



NX.2000 DIN

- VERSIONE BARRA DIN RAIL
6 moduli
- WATERPROOF VERSION
6 modules



NX.2000 Q

- VERSIONE PANNELLO
48x96x100 mm
- PANEL VERSION
48x96x100 mm

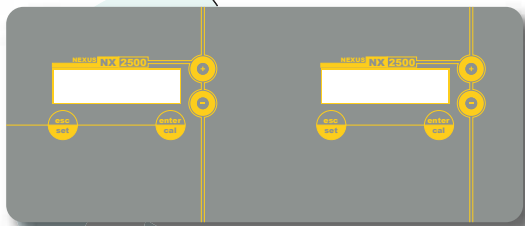

NX.2500 M

- MULTIPARAMETRICO, VERSIONE STAGNO
300x290x143 mm (IP66)
- MULTIPARAMETER, WATERPROOF VERSION
300x290x143 mm (IP66)



WATER TREATMENT DIVISION NEXUS.4000 SERIES

STRUMENTI PER ANALISI DA PROCESSO INSTRUMENTS FOR PROCESS ANALYSIS



APPLICAZIONI APPLICATIONS

- LA SERIE **NEXUS.4000** SVILUPPATA PER SETTORI DI TRATTAMENTO ACQUE E INDUSTRIA, PERMETTE LA MISURA DEI SEGUENTI PARAMETRI: **pH/REDOX, CONDUCIBILITÀ, TORBIDITÀ, CLORO, BISSIDO DI CLORO, OZONO**
- THE **NEXUS.4000**SERIES DEVELOPED FOR WATER TREATMENT AND INDUSTRY, ALLOW THE MEASURING OF: **pH/REDOX, CONDUCTIVITY, TURBIDITY, CHLORINE, CHLORINE DIOXIDE, OZONE**

آتور صنعت
ATOORSANAT

CARATTERISTICHE GENERALI GENERAL FEATURES



- **1 USCITA ANALOGICA** programmabile per la misura
- **4 USCITE DIGITALI** set point ON/OFF: programmazione del range operativo (isteresi/direzione) e tempo di start/stop 000÷999 secondi
- **ALLARME** programmabile per: anomalie strumento, minimo, massimo, ritardo set point, tempo di permanenza (Live Check)
- **LAVAGGIO ELETTRODI** programmazione dell'intervallo (minimo 15 min.) e della durata, durata il lavaggio, tutte le uscite analogiche e digitali sono congelate
- **1 ANALOGUE OUTPUTS** programmable for measure, output limits are freely programmable between range of measures
- **4 DIGITAL OUTPUTS** on/off set point: set of the operating range (hysteresis/direction) and of start/stop time 000÷999 sec
- **ALARM** reporting: instrumental anomalies, minimum, maximum, set point delay, permanence time (Live Check)
- **ELECTRODES WASHING** programming of the time leg, frequency: 00:00÷24:00 hh:mm, minimum time leg: programmable, during the washing phase, all digital and analogue outputs are frozen



CARATTERISTICHE TECNICHE TECHNICAL FEATURES

- **INGRESSO DIGITALE** PER DISABILITAZIONE DEI DOSAGGI
- **CONTROLLI MANUALI** POSSIBILITÀ DI SIMULARE LE USCITE ANALOGICHE E DIGITALI DA TASTIERA
- **COMPENSAZIONE DELLA TEMPERATURA** MEDIANTE SENSORE PT100 CON 3 FILI, OPPURE PT1000
- **DISPLAY GRAFICO 128x64 PIXEL, RETROILLUMINATO**
- **DIGITAL INPUT** TO DISABLE DOSAGE
- **MANUAL CONTROLS** POSSIBILITY TO SIMULATE ALL THE ANALOGUE AND DIGITAL PUTPUTS USING THE KEYBOARD
- **TEMPERATURE COMPENSATION** VIA TEMPERATURE SENSOR PT100 WITH 3 OR 4 WIRES, OR PT1000
- **128x64 PIXEL GRAPHIC DISPLAY, BACKLIT**

RANGE	pH - 0÷14,00 RX - ±1500 mV CD - 0÷20 / 0÷200 / 0÷2.000 / 0÷20.000 / 0÷200.000 µS CL - 0÷2 / 0÷5 / 0÷10 / 0÷20 ppm TB - 0÷0,1 / 0÷10,0 / 0÷100 NTU (solo con sonda only with probe E.CT 2 PVC) OX - 0÷20 ppm
ALIMENTAZIONE POWER SUPPLY	100÷240 VAC 50/60 Hz
USCITA IN CORRENTE CURRENT OUTPUT	0/4÷20 20÷4/0 mA isolata galvanicamente galvanic separation
INGRESSO SONDA TEMPERATURA TEMPERATURE SENSOR INPUT	NTC scala / -10÷+150°C / impostazione manuale e visualizzazione diretta NTC scale / -10÷+150°C / manual setting and direct visualization
SET POINT	2 indipendenti attraverso relé di contatto pulito 20A 250V (carico resistivo) 2 independent throught 20A 250V dry contact relay (resistance load)
RELÉ RELAYS	allarme remoto/lavaggio automatico sonda remote alarm/automatic washing

MODELLI MODELS

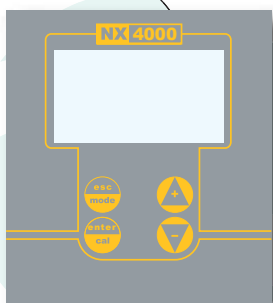

NX.4000 W

- VERSIONE STAGNO
144x144x120 mm
- WATERPROOF VERSION
144x144x120 mm

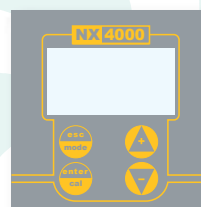

NX.4000 Q

- VERSIONE PANNELLO
96x96x133 mm
- PANEL VERSION
96x96x133 mm



WATER TREATMENT DIVISION NEXUS.5000 SERIES

STRUMENTI INDUSTRIALI INDUSTRIAL INSTRUMENTS



CARATTERISTICHE GENERALI GENERAL FEATURES



- Retroilluminazione a 4 colori per evidenziare le funzioni
- Four different Backlight color to underline functions.

- Porta seriale RS485 isolata con Modbus a protocollo RTU/Ascii
- Display 128 x 128 pixel con icone grafiche per lo stato dell'uscita, del ciclo di lavaggio e menu allarmi
- Valori lampeggianti simultaneamente per le misure e le temperature
- 5 chiavi di controllo per la regolazione e la calibrazione dello strumento
- Alimentatore universale 100--240 Vac 50/60 Hz
- Alimentatore a basso voltaggio 12--32 Vdc or 24 Vac
- A norma CE
- Configurazione outputs All outputs Relay, SSR and Output mA sono configurabili con misura primaria e secondaria

- Serial Port RS485 insulated with Modbus RTU/Ascii Protocol
- Graphic display 128 by 128 pixel resolution monochrome display with graphic icons to show digital output status, washing cycle, alarms menu.
- Simultaneous flashing values for the measurement (numeric + bargraph) and temperature readings.
- Five control keys for instrument calibration and configuration.
- Power Supply
- Universal Power Supply 100--240 Vac 50/60 Hz Low Power Supply 12--32 Vdc or 24 Vac
- CE compliant
- Configuration Outputs All outputs Relay, SSR and Output mA are configurable with primary and secondary measure.

OPZIONI MONTAGGIO MOUNTING OPTIONS

- | | |
|---|--|
| <ul style="list-style-type: none"> • Box di rivestimento • Box montabile a parete in ABS con standard IP65 (144x144x122) • Pannello di montaggio in ABS IP65 solo pannello frontale (96x96x42) | <ul style="list-style-type: none"> • Enclosure Box • Wall mounting ABS plastic material IP65 full box (144x144x122) • Panel mounting ABS IP65 front panel only (96x96x42) |
|---|--|

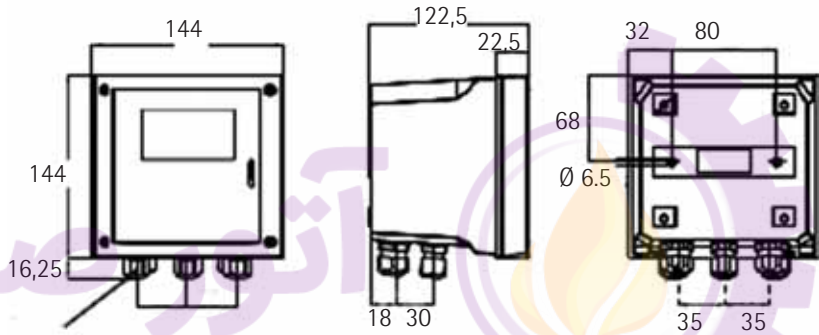
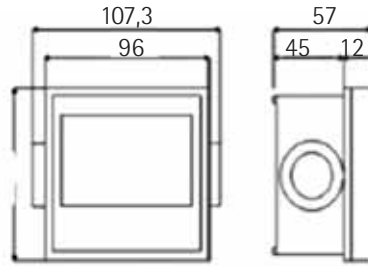

Nexus.5000 Measure Range with PT100/PT1000

Value	Value	Value
pH	0 ÷ 14,00 pH	±0,01pH
ORP	± 2000 mV	±1 mV
Conductivity	0,054 ÷ 200.000 µS	±2%
Flow Rate	0,0000 ÷ 99.999 Liters/Sec.	±0,5Hz
Input 4 ÷ 20mA	0,0000 ÷ 99.999 ppm	±0,01ppm
Temperature	50 ÷ 150 °C (58 ÷ 302 °F ±0,4 °F)	±0,2 °C



WATER TREATMENT DIVISION
NEXUS.6000 SERIES
STRUMENTI INDUSTRIALI INDUSTRIAL INSTRUMENTS



APPLICAZIONI APPLICATIONS

- LA SERIE **NEXUS.6000** SVILUPPATA PER SETTORI DI TRATTAMENTO ACQUE E INDUSTRIA, PERMETTE LA MISURA DEI SEGUENTI PARAMETRI: **pH/REDOX, CONDUCIBILITÀ, TORBIDITÀ, CLORO, OSSIGENO**
- THE **NEXUS.6000**SERIES DEVELOPED FOR WATER TREATMENT AND INDUSTRY, ALLOW THE MEASURING OF: **pH/REDOX, CONDUCTIVITY, TURBIDITY, CHLORINE, OXYGEN**

CARATTERISTICHE GENERALI GENERAL FEATURES



- **2 USCITE ANALOGICHE** uscita 1 programmabile per la per la misura, uscita 2 programmabile per la misura/temperatura /regolazione PID, I limiti delle uscite sono liberamente programmabili all'interno del campo di misura
- **4 USCITE DIGITALI** set point ON/OFF: programmazione del range operativo (isteresi/direzione) e tempo di start/stop 000÷999 secondi
- **REGOLAZIONE PID** impulsi frequenza o PWM (2 set point)
- **ALLARME** programmabile per: anomalie strumento, minimo, massimo, ritardo set point, tempo di permanenza (Live Check)
- **LAVAGGIO ELETTRODI** programmazione dell'intervallo (minimo 15 min.) e della durata, durata il lavaggio, tutte le ucite analogiche e digitali sono congelate
- **2 ANALOGUE OUTPUTS** output 1 programmable for measure, output 2 programmable for measure/temperature/PID regulation, outputs limits are freely programmable between the range of measures
- **4 DIGITAL OUTPUTS** on/off set point: set of the operating range (hysteresis /direction) and of start/stop time 000÷999 sec
- **PID REGULATION** pulse frequency or PWM (2 set point)
- **ALARM** reporting: instrumental anomalies, minimum, maximum, set point delay, permanence time (Live Check)
- **ELECTRODES WASHING** programming of the time leg, frequency: 00:00÷24:00 hh:mm, minimum time leg: programmable, during the washing phase, all digital and analogue outputs are frozen



CARATTERISTICHE TECNICHE / TECHNICAL FEATURES

- **REGISTRAZIONE DATI** MEMORIA FLASH INTERNA 4 MB (CIRCA 16.000 REG.)
- **INGRESSO DIGITALE** PER DISABILITAZIONE DEI DOSAGGI
- **PORTA SERIALE RS485** PER IL SET UP E L'ACQUISIZIONE IN REAL TIME DA REMOTO
- **CONTROLLI MANUALI** POSSIBILITÀ DI SIMULARE LE USCITE ANALOGICHE E DIGITALI DA TASTIERA
- **COMPENSAZIONE DELLA TEMPERATURA** MEDIANTE SENSORE PT100 CON 3 FILI, OPPURE PT1000
- **DISPLAY GRAFICO 128x64 PIXEL, RETROILLUMINATO**
- **VISUALIZZAZIONE** VALORI SIMULTANEI DELLA MISURA (NUMERICA E BARGRAPH) E TEMPERATURA, VALORI DELLE USCITE IN SCROLLING, ICONE GRAFICHE PER: STATO DELLE USCITE, CICLO LAVAGGIO, REGISTRAZIONE DATI, ALLARMI

- **DATA STORAGE** INTERNAL FLASH 4 MB MEMORY (NEAR TO 16.000 RECORDS)
- **DIGITAL INPUT** TO DISABLE DOSAGE
- **RS485 SERIAL INPUT** FOR SET UP AND REAL TIME DATA ACQUISITION FROM REMOTE OR FOR STORED DATA DOWNLOAD (using a dedicate SW), USB TO DOWNLOAD (software required) MODBUS RTU COMMUNICATION PROTOCOL
- **MANUAL CONTROLS** POSSIBILITY TO SIMULATE ALL THE ANALOGUE AND DIGITAL PUTPUTS USING THE KEYBOARD
- **TEMPERATURE COMPENSATION** VIA TEMPERATURE SENSOR PT100 WITH 3 OR 4 WIRES, OR PT1000
- **128x64 PIXEL GRAPHIC DISPLAY, BACK LIGHTED**
- **VISUALIZATION** SIMULTANEOUS VALUES OF THE MEASURE (NUMERIC+BARGRAPH) AND TEMPERATURE, ANALOGUE OUTPUTS VALUE IN SCROLLING, GRAPHIC ICONS SHOWING: DIGITAL OUTPUTS STATE, DATA STORAGE, WASHING CYCLE, ALARMS

RANGE	pH - 0÷14,00	risoluzione	resolution	0,01	pH
	RX - ±1500 mV	risoluzione	resolution	1	mV
	CD - 0÷20 / 0÷200 / 0÷2.000 / 0÷20.000 / 0÷200.000	risoluzione	resolution	0,01 / 0,1 / 1 / 10	
				µS	
	CL - 0÷2 / 0÷5 / 0÷10 / 0÷20	risoluzione	resolution	0,01	ppm
	TB - 0÷4,0 / 0÷40,0 / 0÷400	risoluzione	resolution	0,01 / 1	NTU
TB1 (Solidi Sospesi / Suspended Solid) - 0÷9999	gr/l				
ALIMENTAZIONE / POWER SUPPLY	OX - 0÷20	risoluzione	resolution	0,1	ppm
	100÷240 VAC 50/60 Hz				

MODELLI / MODELS

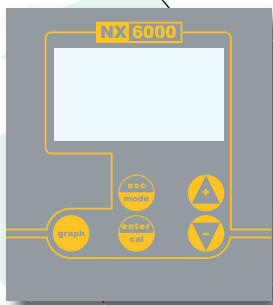

NX.6000 W

- VERSIONE STAGNO
144x144x120 mm
- WATERPROOF VERSION
144x144x120 mm



NX.6000 Q

- VERSIONE PANNELLO
96x96x133 mm
- PANEL VERSION
96x96x133 mm



WATER TREATMENT DIVISION
NEXUS.6500 SERIES
STRUMENTI INDUSTRIALI INDUSTRIAL INSTRUMENTS



APPLICAZIONI APPLICATIONS

- LA SERIE **NEXUS.6500** SVILUPPATA PER SETTORI DI TRATTAMENTO ACQUE E INDUSTRIA, PERMETTE LA MISURA DEI SEGUENTI PARAMETRI: **pH/REDOX, CONDUCIBILITÀ, TORBIDITÀ, CLORO, OSSIGENO**
- THE **NEXUS.6500**SERIES DEVELOPED FOR WATER TREATMENT AND INDUSTRY, ALLOW THE MEASURING OF: **pH/REDOX, CONDUCTIVITY, TURBIDITY, CHLORINE, OXYGEN**

CARATTERISTICHE GENERALI GENERAL FEATURES



- **2 USCITE ANALOGICHE** uscita 1 programmabile per la per la misura, uscita 2 programmabile per la misura/temperatura /regolazione PID, I limiti delle uscite sono liberamente programmabili all'interno del campo di misura
- **4 USCITE DIGITALI** set point ON/OFF: programmazione del range operativo (isteresi/direzione) e tempo di start/stop 000÷999 secondi
- **REGOLAZIONE PID** impulsi frequenza o PWM (2 set point)
- **ALLARME** programmabile per: anomalie strumento, minimo, massimo, ritardo set point, tempo di permanenza (Live Check)
- **LAVAGGIO ELETTRODI** programmazione dell'intervallo (minimo 15 min.) e della durata, durata il lavaggio, tutte le uscite analogiche e digitali sono congelate
- **2 ANALOGUE OUTPUTS** output 1 programmable for measure, output 2 programmable for measure/temperature/PID regulation, outputs limits are freely programmable between the range of measures
- **4 DIGITAL OUTPUTS** on/off set point: set of the operating range (hysteresis /direction) and of start/stop time 000÷999 sec
- **PID REGULATION** pulse frequency or PWM (2 set point)
- **ALARM** reporting: instrumental anomalies, minimum, maximum, set point delay, permanence time (Live Check)
- **ELECTRODES WASHING** programming of the time leg, frequency: 00:00÷24:00 hh:mm, minimum time leg: programmable, during the washing phase, all digital and analogue outputs are frozen



CARATTERISTICHE TECNICHE / TECHNICAL FEATURES

- **REGISTRAZIONE DATI** MEMORIA FLASH INTERNA 4 MB (CIRCA 16.000 REG.)
- **INGRESSO DIGITALE** PER DISABILITAZIONE DEI DOSAGGI
- **PORTA SERIALE RS485** PER IL SET UP E L'ACQUISIZIONE IN REAL TIME DA REMOTO
- **CONTROLLI MANUALI** POSSIBILITÀ DI SIMULARE LE USCITE ANALOGICHE E DIGITALI DA TASTIERA
- **COMPENSAZIONE DELLA TEMPERATURA** MEDIANTE SENSORE PT100 CON 3 FILI, OPPURE PT1000
- **DISPLAY GRAFICO 128x64 PIXEL, RETROILLUMINATO**
- **VISUALIZZAZIONE** VALORI SIMULTANEI DELLA MISURA (NUMERICA E BARGRAPH) E TEMPERATURA, VALORI DELLE USCITE IN SCROLLING, ICONE GRAFICHE PER: STATO DELLE USCITE, CICLO LAVAGGIO, REGISTRAZIONE DATI, ALLARMI

- **DATA STORAGE** INTERNAL FLASH 4 MB MEMORY (NEAR TO 16.000 RECORDS)
- **DIGITAL INPUT** TO DISABLE DOSAGE
- **RS485 SERIAL INPUT** FOR SET UP AND REAL TIME DATA ACQUISITION FROM REMOTE OR FOR STORED DATA DOWNLOAD (using a dedicate SW), USB TO DOWNLOAD (software required) MODBUS RTU COMMUNICATION PROTOCOL
- **MANUAL CONTROLS** POSSIBILITY TO SIMULATE ALL THE ANALOGUE AND DIGITAL PUTPUTS USING THE KEYBOARD
- **TEMPERATURE COMPENSATION** VIA TEMPERATURE SENSOR PT100 WITH 3 OR 4 WIRES, OR PT1000
- **128x64 PIXEL GRAPHIC DISPLAY, BACKLIT**
- **VISUALIZATION** SIMULTANEOUS VALUES OF THE MEASURE (NUMERIC+BARGRAPH) AND TEMPERATURE, ANALOGUE OUTPUTS VALUE IN SCROLLING, GRAPHIC ICONS SHOWING: DIGITAL OUTPUTS STATE, DATA STORAGE, WASHING CYCLE, ALARMS

RANGE	pH / Rx - 0÷14,00 / ±1500 mV
	pH / CD - 0÷14,00 / 0÷20 / 0÷200 / 0÷2.000 / 0÷20.000 µS
	pH / OX - 0÷14,00 / 0÷20 ppm
	TB / OX - 0÷0,1 / 0÷10,0 / 0÷100 FTU NTU / 0÷20 ppm
	pH / CL - 0÷14,00 / 0÷2 / 0÷5 / 0÷10 / 0÷200 ppm
	pH / CL - 0÷20 / 0÷200 / 0÷2.000 / 0÷20.000 µS / 0÷2 / 0÷5 / 0÷10 / 0÷200 ppm
	Solidi Sospesi Suspended Solids / OX - 0÷9999 gr/l / 0÷200 ppm
Solidi Sospesi Suspended Solids / CL	
	0÷9999 gr/l / 0÷2 / 0÷5 / 0÷10 / 0÷200 ppm
ALIMENTAZIONE POWER SUPPLY	100÷240 VAC 50/60 Hz

MODELLI / MODELS

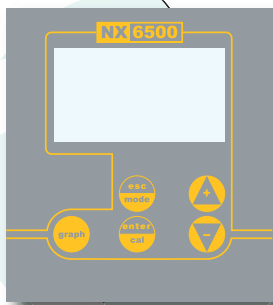

NX.6500 W

- VERSIONE STAGNO
144x144x120 mm
- WATERPROOF VERSION
144x144x120 mm



WATER TREATMENT DIVISION NEXUS.7000 SERIES

STRUMENTO MULTIPARAMETRICO MULTIPARAMETER INSTRUMENTS



CARATTERISTICHE GENERALI GENERAL FEATURES



NX.7000

- **CONTROLLER COMPATTO E DI SEMPLICE UTILIZZO**, permette la misura dei seguenti parametri: **pH/Rx, CLORO LIBERO, TEMPERATURA, 2 INGRESSI PER SONDE DI LIVELLO PRODOTTI CHIMICI**
- **4 USCITE DIGITALI**
- **PROTEZIONE IP65**
- **3 RELÉ CON ALIMENTAZIONE PER POMPE DOSATRICI**
- **2 RELÉ CONTATTO PULITO PER STATO ALLARME**
- **2 USCITE IN CORRENTE (4÷20 mA)**
- **2 CANALI FREQUENZA "COLLETTORI APERTI"**
- **PORTA SERIALE RS485 CON PROTOCOLLO DI COMUNICAZIONE MODBUS RTU**
- **DISPLAY ALFANUMERICO, 4 LINEE E 20 CARATTERI**
- **COMPACT EASY SETTING DEVICE CONTROL INSTRUMENT**, allow the measuring of: **pH/Rx, FREE CHLORINE, TEMPERATURE, 2 INPUT FOR LEVEL PROBE FOR CHEMICAL PRODUCTS**
- **HIGH RESOLUTION MEASURE**
- **IP65 ENCLOSURE BOX**
- **3 RELAY WITH POWER SUPPLY FOR DOSING PUMP**
- **2 RELAY DRY CONTACT FOR ALARM STATUS**
- **2 4÷20 mA CURRENT OUTPUT**
- **2 FREQUENCY CHANNEL "OPEN COLLECTOR"**
- **SERIAL PORT RS485 WITH MODBUS RTU STANDARD**
- **ALPHANUMERIC DISPLAY WITH 4 LINE AND 20 LETTERS**

CARATTERISTICHE TECNICHE TECHNICAL FEATURES

RANGE	pH - 0÷14,00
	RX - ±1500 mV
	CD - 1÷200 - 10÷2000 - 100÷20000 - 200÷50000 µS
	CL (amperometric-potentiostatic) / CL DIOXIDE (potentiostatic probe)
	0÷0,50 - 0÷1,00 - 0÷2,00 - 0÷5,00 - 0÷10,0 - 0÷20,0 - 0÷200,0 ppm
	TEMPERATURE - 0÷100 °C with PT100
VERSIONE MONPARAMETRO SINGLE PARAMETER VERSION	CLORO CHLORINE
VERSIONE DOPPIO PARAMETRO DOUBLE PARAMETER VERSION	PH-CLORO PH-CHLORINE
ALIMENTAZIONE POWER SUPPLY	100÷240 VAC 50/60 Hz

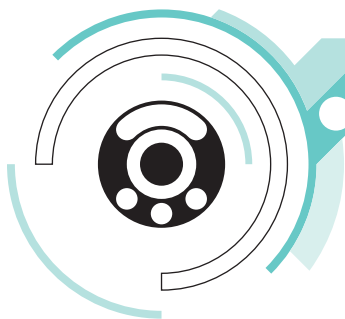

SETUP SETTING MENU

```

3A PH DOSING
3A1 RELAY ON/OFF
3A2 FWM (FREQUENCY OUTPUT)
3A3 OUTMA (mA CURRENT OUTPUT) ↓
3A4 ALARM
    
```



```

3A1 REALY PH
>ON/OFF
TIMED (TIMED DOSING)
PWM (PROPORTIONAL DOSING)
    
```

- DAL MENÙ RELÉ É POSSIBILE PILOTARE LA POMPA DOSATRICE ANALOGICA
- IN QUESTO ESEMPIO LA POMPA DOSA IN MODALITÀ COSTANTE

- BY RELAY MENU IT IS POSSIBLE TO DRIVE THE ANALOGICAL DOSING PUMP
- IN THIS EXAMPLE THE PUMP DOSSES IN CONTANT MODE

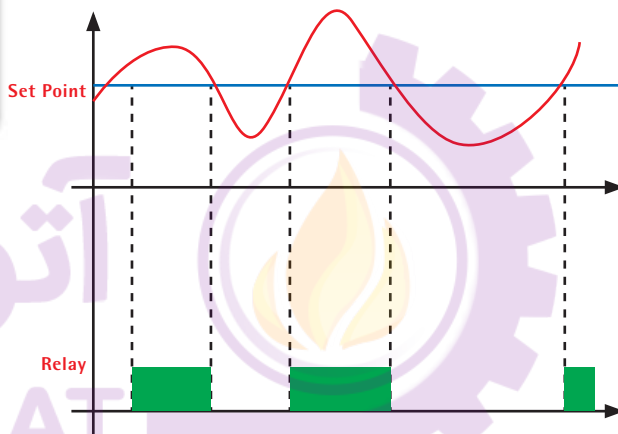

ON/OFF DOSING BY RELAY

ITEM	DEFAUL VALUE	RANGE
Set Point	7,20 pH	0÷14 pH
Time Dosing	Acid	Acid/Alka
Hysteresis	Off	0.10÷3 pH
Hysteresis Time	Off	1÷900 Sec
Delay Start	Off	1÷900 Sec
Delay End	Off	1÷900 Sec



WATER TREATMENT DIVISION DI.MPO SERIES

MISURATORI DI PORTATA A INDUZIONE MAGNETICA
MAGNETIC INDUCTION FLOW METER



CARATTERISTICHE GENERALI - GENERAL FEATURES

- IL CAMPO DI ECCITAZIONE MAGNETICA E' DEL TIPO AD ONDA RETTANGOLARE A BASSA FREQUENZA. IN TAL MODO VIENE INCREMENTATA LA STABILITA' DELLA MISURA DI PORTATA E SI HA UN BASSO CONSUMO ELETTRICO
- THE MAGNETIC FIELD EXCITATION IS A PROGRAMMABLE RECTANGULAR WAVE WITH LOW FREQUENCY. IT INCREASES THE STABILITY OF FLOW MEASUREMENT AND HAS LOW CONSUMPTION



- Dotato di un veloce **MICROPROCESSORE A 16 BIT DI ELEVATA PRECISIONE**
- **FUNZIONE DI MISURA IN ENTRAMBE LE DIREZIONI** sono visualizzabili sia la portata in direzione diretta che inversa.
- **3 TOTALIZZATORI INTERNI** sono in grado di visualizzare i volumi in direzione diretta, inversa e la loro differenza
- Il trasmettitore multifunzione è dotato di **FUNZIONE DI AUTO-TEST E DI AUTODIAGNOSI**
- Le impostazioni dei parametri e i valori dei totalizzatori sono salvate su **MEMORIA EEPROM** quando lo strumento viene spento
- **TENSIONE ISOLAMENTO DI 500 V**
- It uses **16 BIT MICROPROCESSOR**, fast processing and high accuracy
- **DUAL DIRECTION MEASUREMENT FUNCTION** it can display forward direction flow-rate and reverse direction flow rate
- **3 INSIDE COUNTERS** can respectively display forward direction volume, reverse direction volume and the different volume of both directions
- Multifunction intelligent transmitter has **SELF-TEST AND SELF-DIAGNOSIS FUNCTION**
- **EEPROM MEMORY** can save the setting and the counters when power off
- **THE ISOLATING VOLTAGE IS MORE THAN 500 V**



MODELLI E CARATTERISTICHE TECNICHE - MODELS AND TECHNICAL FEATURES



DI.MPO 01

CONDIZIONI AMBIENTALI / AMBIENT CONDITIONS	-25°C ÷ +55°C temperatura ambiente / ambient temperature 5% ÷ 100% umidità relativa / relative humidity 86 ÷ 106 bar pressione ambiente / ambient pressure
CONDIZIONI DI FUNZIONAMENTO / OPERATING CONDITIONS	conduttività fluido / fluid conductivity >5µS/cm pressioni / pressures 4,0 Mpa (DN15÷DN150) 1,6 Mpa (DN100÷DN450) 1,0 Mpa (DN200÷DN1.000) 0,6 Mpa (DN1.200÷DN1.600) temperatura / temperature Remote Vers. <80°C (rivestimento in gomma / rubber coating) <150°C (180°C max PTFE) Compact Vers. <70°C
ALIMENTAZIONE / POWER SUPPLY	85 ÷ 265 VAC, 24 VAC / consumo / consumption <20W
DN TUBO / DN PIPE	DN15 ÷ DN1.600
RANGE VELOCITÀ / VELOCITY RANGE	0m/s ÷ 10m/s
MATERIALE TUBO / PIPE MATERIAL	SS 321
MATERIALE ELETTRODI / ELECTRODES MATERIAL	SS 316 TI, Hastelloy B, Hastelloy C, Titanium, Tantalum
MATERIALE FLANGE / FLANGED MATERIAL	UNI 2223 in Carbon Steel, SS316
PROTEZIONE / PROTECTION DEGREE	Remote Vers. IP67/IP68 (optional) - Compact Vers. IP67
ACCURATEZZA / ACCURACY	±0,5% del valore misurato / of the measured value (optional ±0,2%, ±0,3%)
RIPETIBILITÀ / REPEATABILITY	0,17% del valore misurato nel range di velocità 0,5÷10 m/s per accuratezza ±0,5% 0,17% of the measured value for accuracy ±0,5%
USCITA CORRENTE / ANALOG OUTPUT	4÷20 mA (0÷10 mV optional) resistenza di carico / load resistance 0÷1,5 Kohm x 0÷10 mV, 0÷750 Kohm x 4÷20 mA errore / basic error ±10µA del valore misurato / measured value plus basic error
USCITA IN FREQUENZA O IMPULSO / FREQUENCY OR PULSE OUTPUT	frequenza impostabile 1÷5.000 Hz per entrambe le direzioni di misura impulso fino a 15.000 imp./min per entrambe le direzioni di misura, durata d'impulso fino a 25 ms frequency can be set between 1÷5.000 Hz for forward direction and reserve direction pulse can be up to 15.000 imp./min for forward and reserve direction. The pulse width is up to 25 ms
USCITE ALLARMI / ALARM OUTPUTS	n°2 sull'uscita del transistor in configurazione open collector con isolamento galvanico n°2 are the open collector transistor output with galvanic isolation
USCITA SERIAL / SERIAL OUTPUT (optional)	RS485 optoisolata / opto isolated
DAMPING	2÷100s (90%) velocità adeguamento misura istantanea / speed of adjustment measure instantaneous
CUT-OFF DI PORTATA / FLOW CUT-OFF	regolabile 0,0÷9,9 % della Qmax. al di sotto del valore impostato la visualizzazione del flusso istantaneo e gli output sono forzati a zero adjustable 0,0÷9,9 %. The value for flow cut off is stated as a percentage that relates to the upper range value of the flowrate



MODELLI E CARATTERISTICHE TECNICHE - MODELS AND TECHNICAL FEATURES



DI.MPO 02

CONDIZIONI AMBIENTALI / AMBIENT CONDITIONS	-20°C ÷ +75°C temperatura ambiente / ambient temperature 0% ÷ 100RH, 65°C umidità relativa / relative humidity 86 ÷ 106 bar pressione ambiente / ambient pressure
CONDIZIONI DI FUNZIONAMENTO / OPERATING CONDITIONS	conduttività fluido / fluid conductivity >5µS/cm pressioni / pressures 4,0 Mpa (DN15÷DN150) 1,6 Mpa (DN100÷DN450) 1,0 Mpa (DN200÷DN1.000) temperatura / temperature Remote Vers. <80°C (rivestimento in gomma / rubber coating) Compact Vers. -20 ÷ +70°C
ALIMENTAZIONE / POWER SUPPLY	85 ÷ 265 VAC, 24 VAC / consumo / consumption 6W, 8W max
DN TUBO / DN PIPE	DN10 ÷ DN1.000
RANGE VELOCITÀ / SPEED RANGE	0m/s ÷ 10m/s
MATERIALE TUBO / PIPE MATERIAL	SS 321
RIVESTIMENTO / COATING TYPE	gomma / rubber PTFE
MATERIALE ELETTRODI / ELECTRODES MATERIAL	SS 316 , Hastelloy C
MATERIALE FLANGE / FLANGED MATERIAL	UNI 2223 in Carbon Steel
PROTEZIONE / PROTECTION DEGREE	Remote Vers. IP67/IP68 (optional) - Compact Vers. IP67
ACCURATEZZA / ACCURACY	±0,5% del valore misurato / of the measured value (optional ±0,2%, ±0,3%)
RIPETIBILITÀ / REPEATABILITY	0,1% del valore misurato per accuratezza / of the measured value for accuracy
USCITA CORRENTE / ANALOG OUTPUT	4÷20 mA, 0,5÷10 m/s
USCITA IN FREQUENZA O IMPULSO / FREQUENCY OR PULSE OUTPUT	frequenza / impostabile 1÷5.000 Hz per entrambe le direzioni di misura impulso / possibilità di impostare la larghezza d'impulso per lo stato uscita H o L frequency can be set between 1÷5.000 Hz for forward direction and reserve direction pulse width can be for the output state H or L
USCITA SERIAL / SERIAL OUTPUT (optional)	RS485 con protocollo / with protocol MODBUS
DAMPING	0,1÷99 sec.
CUT-OFF DI PORTATA / FLOW CUT-OFF	regolabile 0,0÷9,9 % della Qmax. al di sotto del valore impostato la visualizzazione del flusso istantaneo e gli output sono forzati a zero adjustable 0,0÷9,9 %. The value for flow cut off is stated as a percentage that relates to the upper range value of the flowrate



DI.MPO 03

CONDIZIONI AMBIENTALI / AMBIENT CONDITIONS	-40°C ÷ +75°C temperatura ambiente / ambient temperature 0% ÷ 100RH, 65°C umidità relativa / relative humidity 86 ÷ 106 bar pressione ambiente / ambient pressure
CONDIZIONI DI FUNZIONAMENTO / OPERATING CONDITIONS	conduttività fluido / fluid conductivity >5µS/cm pressioni / pressures 1,6 Mpa (DN10÷DN150) temperatura / temperature Remote Vers. <120°C (PTFE) Compact Vers. -40 ÷ +75°C
ALIMENTAZIONE / POWER SUPPLY	90 ÷ 250 VAC, 24 VAC or 18 ÷ 36 VAC / consumo / consumption 10W
DN TUBO / DN PIPE	DN10 ÷ DN150
RANGE VELOCITÀ / SPEED RANGE	0,2m/s ÷ 10m/s
MATERIALE TUBO / PIPE MATERIAL	SS 321
RIVESTIMENTO / COATING TYPE	PTFE, PFA
MATERIALE ELETTRODI / ELECTRODES MATERIAL	SS 316 Ti, Hastelloy B, Hastelloy C, Titanium, Tantalum
MATERIALE FLANGE / FLANGED MATERIAL	girella swivel DIN 11851 / DIN CLAMP in SS
PROTEZIONE / PROTECTION DEGREE	Remote Vers. IP67/IP68 (optional) - Compact Vers. IP67
ACCURATEZZA / ACCURACY	±0,5% del valore misurato nel range di velocità / of the measured value for velocity 0,5÷10 m/s)
RIPETIBILITÀ / REPEATABILITY	0,1% del valore misurato per accuratezza / of the measured value for accuracy
USCITA CORRENTE / ANALOG OUTPUT	4÷20 mA, 0÷1.000 ohm
USCITA IN FREQUENZA O IMPULSO / FREQUENCY OR PULSE OUTPUT	frequenza / impostabile 1÷10.000 Hz per entrambe le direzioni di misura impulso / possibilità di impostare la larghezza d'impulso per lo stato uscita H o L frequency can be set between 1÷10.000 Hz for forward direction and reserve direction pulse width can be for the output state H or L
USCITA SERIAL / SERIAL OUTPUT (optional)	RS485 con protocollo / with protocol MODBUS
DAMPING	0,1÷99 sec.
CUT-OFF DI PORTATA / FLOW CUT-OFF	regolabile 0,0÷9,9 % della Qmax. al di sotto del valore impostato la visualizzazione del flusso istantaneo e gli output sono forzati a zero adjustable 0,0÷9,9 %. The value for flow cut off is stated as a percentage that relates to the upper range value of the flowrate



INSTRUMENT PRODUCTS

ABACO PER LA SELEZIONE OTTIMALE DEL TUBO DI MISURA - ABACUS FOR THE OPTIMAL SELECTION OF THE MESURING TUBE

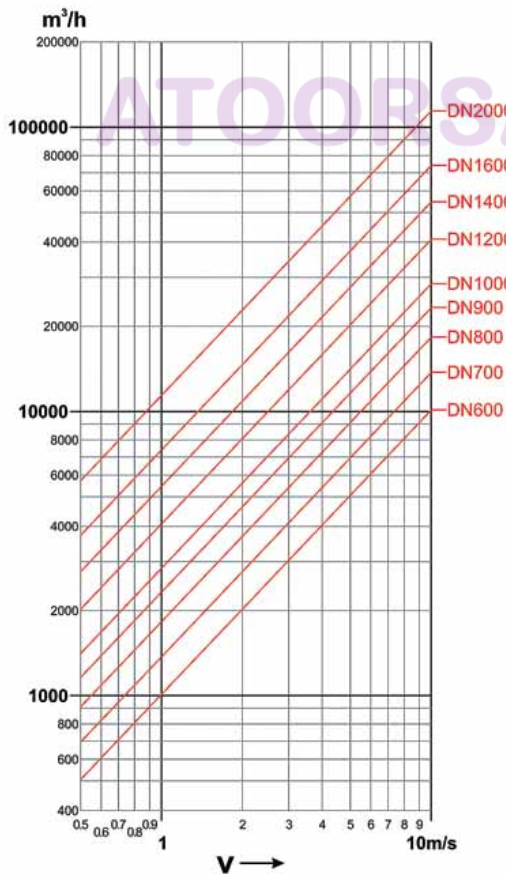
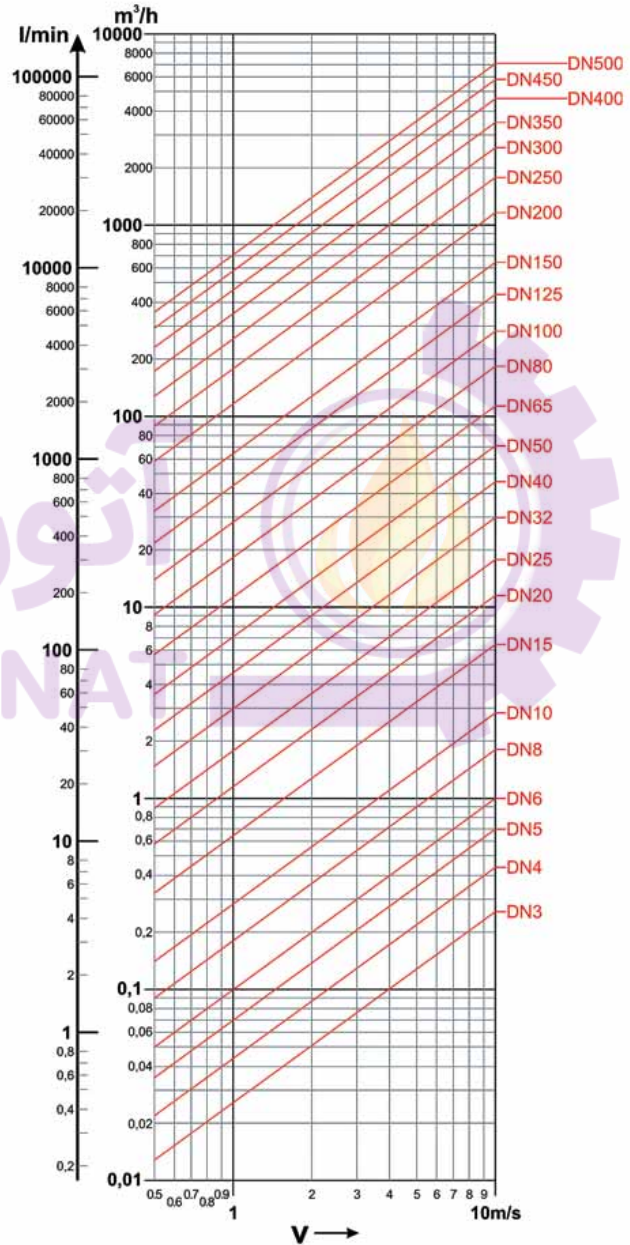
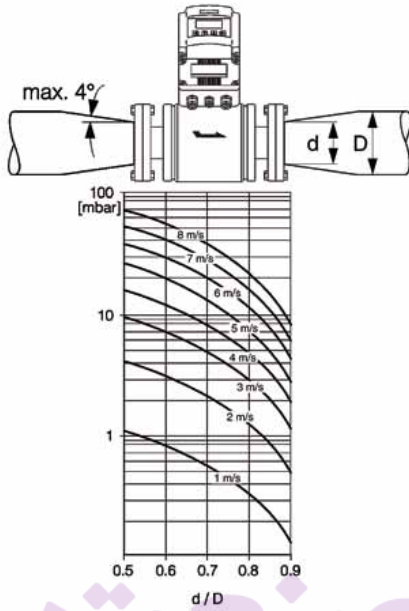



WATER TREATMENT DIVISION DLMPU SERIES

MISURATORI DI PORTATA A "TEMPO TRANSITO"
"TRANSIT TIME" FLOW METER



CARATTERISTICHE GENERALI - GENERAL FEATURES

- LA TECNOLOGIA DSP (DIGITAL SIGNAL PROCESSING), GARANTISCE UNA BASSA SENSIBILITA' DEL SISTEMA VERSO EVENTUALI POTENZIALI FATTORI DI DISTURBO. LE DIMENSIONI DEL TUBO POSSONO VARIARE 20 ÷ 4000 mm (UTILIZZANDO DIVERSI TRASDUTTORI). POICHÉ I TRASDUTTORI SONO APPLICATI ESTERNAMENTE AL TUBO, NON SONO A CONTATTO CON IL LIQUIDO E NON HANNO PARTI MOBILI, IL TRASMETTITORE NON SUBISCE DANNI DA USURA, DA INCROSTAZIONI O DA PRESSIONE.

- THE DSP TECHNOLOGY (DIGITAL SIGNAL PROCESSING) ENSURE A LOW SENSIBILITY OF THE INSTRUMENT AGAINST POTENTIAL TRANSIENT FACTORS. THE SIZE OF THE PIPE MAY VARY 20 ÷ 4000 MM (USING DIFFERENT TRANSDUCERS). SINCE THE TRANSDUCERS ARE APPLIED EXTERNALLY TO THE TUBE, NOT IN CONTACT WITH THE LIQUID AND HAVE NO MOVING PARTS, THE TRANSMITTER WILL NOT BE DAMAGED BY WEAR, BY FOULING OR PRESSURE



- Tutti i **VALORI DI CONFIGURAZIONE** inseriti dall'utente vengono salvati nella **EE PROM**, protetta da password

- Il Trasmettitore è **DOTATO DI UN OROLOGIO PER LA MEMORIZZAZIONE DELLA DATA E DELL'ORA DEL RILEVAMENTO DELLA MISURA**, e funziona a batteria. **IN CASO DI INTERRUZIONE DELL'ALIMENTAZIONE** sarà necessario **RE-IMPOSTARE I VALORI (TEMPORALI)** andati persi. **IN CASO DI ERRATA IMPOSTAZIONE DEL TOTALIZZATORE, LE ALTRE FUNZIONI NON VENGONO COMPROMESSE**

- Composto da un **CONVERTITORE DIGITALE E 2 TRASDUTTORI AD ULTRASUONI CLAMP-ON O AD INSERZIONE**

- All **CONFIGURATION USER-ENTERED VALUES** are saved in **EE PROM**, PW protected

- The Transmitter is **EQUIPPED WITH A CLOCK TO STORE THE MEASURE DETECTION DATE AND TIME** operated by battery

- **IN CASE OF POWER FAILURE** will be necessary **TO RE-SET THE LOST. IN CASE OF INCORRECT SETTING OF THE TOTALIZER, THE OTHER FUNCTIONS ARE NOT COMPROMISED**

- Is composed by a **DIGITAL CONVERTER AND 2 CLAMP-ON OR INSERTION ULTRASONIC TRANSDUCERS**



MODELLI E CARATTERISTICHE TECNICHE - MODELS AND TECHNICAL FEATURES



DI.MPU 01

DN TUBE DN PIPE	DN20 ÷ DN4.000
MATERIALE TUBO PIPE MATERIAL	Acciaio, Acciaio INOX, Ghisa, Rame, PVC, Alluminio, Vetroresina (Cemento con trasduttori ad inserzione) Steel, Stainless Steel, Cast Iron, Copper, PVC, Aluminium, Fiberglass (Cement with insertion trasnducers)
TOTALIZZATORE TOTALIZER	7 digit per portata differenziale diretta o inversa for differential direct and reverse flow
RANGE VELOCITÀ SPEED RANGE	±32 m/s
LINEARITÀ LINEARITY	0,5% ripetibilità repeatability - 0,2% accuratezza totale total accuracy ±1%
TEMPO DI RISPOSTA RESPONSE TIME	1÷999 sec. programmabile programmable
DISPLAY	2x2016 caratteri alfanumerico alphanumeric characters
TASTIERA KEYPAD	4 pulsanti a membrana membrane keys
DATI VISUALIZZATI DATA SHOWN	port. istantanea, tot. della portata, altro instant flow rate, total flow, other
TOTALIZZATORI VOLUMI INTERNI	totalizzatore, contatore per portate dirette, contatore per portate inverse a 7 digit
TOTALIZERS INTERNAL VOLUME	7 digit totalizer, direct and reverse flow
SICUREZZA SECURITY	settaggio e modifica impostazioni protette da password setting and changing password protected
DATA LOGGER	memoria automatica del flusso totale degli ultimi 64 giorni, 64 mesi, 5 anni automatic memory: total flow of the last 64 days, 64 months, 5 years
INPUT	fino a 5 ingressi 4÷20 mA up to five 4÷20 mA inputs
OUTPUT	selezione selectable 4÷20 mA / 0÷20 mA
USCITA IN FREQUENZA FREQUENCY OUTPUT	programmabile programmable 10÷9999 Hz
RELÉ USCITA OUTPUT RELAY	per totalizzatori impulsi o allarmi pulse or alarm totalizer
UMIDITÀ MAX MAX HUMIDITY	85% RH non condensante (40°C), temperatura di processo sensore 0÷150°C
	85% RH not condensing (40°C) process temperature sensor 0÷150°C
UMIDITÀ SENSORE SENSOR HUMIDITY	98% RH non condensante not condensing (40°C)
ALIMENTAZIONE POWER SUPPLY	230 VAC / 24 VDC
CUSTODIA CASING	alluminio, montaggio a parete aluminum, wall mounting



DI.MPU 02 PORTATILE PORTABLE

DN TUBE DN PIPE	DN20 ÷ DN4.000
MATERIALE TUBO PIPE MATERIAL	Acciaio, Acciaio INOX, Ghisa, Rame, PVC, Alluminio, Vetroresina (Cemento con trasduttori ad inserzione) Steel, Stainless Steel, Cast Iron, Copper, PVC, Aluminium, Fiberglass (Cement with insertion trasnducers)
TOTALIZZATORE TOTALIZER	7 digit per portata differenziale diretta o inversa for differential direct and reverse flow
RANGE VELOCITÀ SPEED RANGE	±32 m/s
LINEARITÀ LINEARITY	0,5% ripetibilità repeatability - 0,2% accuratezza totale total accuracy ±1%
TEMPO DI RISPOSTA RESPONSE TIME	1÷999 sec. programmabile programmable
DISPLAY	4 righe, 16 caratteri alfanumerico 4 digits, 16 alphanumeric characters
TASTIERA KEYPAD	16+2 pulsanti a membrana membrane keys
DATI VISUALIZZATI DATA SHOWN	port. istantanea, tot. della portata, altro instant flow rate, total flow, other
TOTALIZZATORI VOLUMI INTERNI	totalizzatore, contatore per portate dirette, contatore per portate inverse a 7 digit
TOTALIZERS INTERNAL VOLUME	7 digit totalizer, direct and reverse flow
SICUREZZA SECURITY	settaggio e modifica impostazioni protette da password setting and changing password protected
DATA LOGGER	capacità di memorizzazione 2.000 records storage capacity of 2.000 records
INPUT	fino a 5 ingressi 4÷20 mA up to five 4÷20 mA inputs
OUTPUT	selezione selectable 4÷20 mA / 0÷20 mA
USCITA IN FREQUENZA FREQUENCY OUTPUT	programmabile programmable 10÷9999 Hz
INTERFACCIA INTERFACE	RS-232C (optional)
CUSTODIA CASING	ABS
ALIMENTAZIONE POWER SUPPLY	per mezzo di alimentazione esterno 100÷253 VAC o tramite 3 BATTERIE AAA Ni-mH integrate, ricaricabili e completamente cariche durano circa 10 ore external power supply 100÷253 VAC or 3 AAA Ni-mH integrated rechargeable batteries that last about 10 hours fully charged



WATER TREATMENT DIVISION DI.MPU SERIES

MISURATORI DI PORTATA CON SENSORE AD ULTRASUONI
FLOW METER WITH ULTRASONIC SENSOR



MODELLI E CARATTERISTICHE TECNICHE - MODELS AND TECHNICAL FEATURES



DI.MPU 03

RANGE	portata flow rate 0÷9999 mc/h livello level 0,30÷5.00 mt temperatura temperature 0÷100 bar
PRECISIONE PRECISION DISPOSITIVI (esponenti per il calcolo della portata PDM) DEVICES (representatives for calculating flow PMD)	±0,2% F.S. RETTANG (stramazzo rettangolare rectangular weir) TRAPEZ (stramazzo Cipolletti Cipolletti weir) VENTURI (canale Venturi Venturi weir) PARSHALL (canale Parshall Parshall flume) L LEOPOLD (canale Leopold Lago Leopold Lago flume) STRAM. V (stramazzo a "V" "V" notch) ALTRO OTHER (esponente liberamente programmazione, tabella con 20 punti per libera programmazione exponent freely programmable, table with 20 points for free programming)
TOTALIZZATORE TOTALIZER	assoluto a 9 digit salvato su flash EE PROM non azzerabile parziale a 9 digit azzerabile 1 x absolute 9 digit not resettable saved on flash EE PROM 1 x partial 9 digit resettable
HARDWARE	LCD STN Grafico 128x64 retroilluminato visualizzazione contemporanea di: portata istantanea, volume totalizzato, temperatura, stato delle uscite digitali, eventi in allarme in scrolling: livello, stato delle uscite analogiche, totalizzatore azzerabile Graphic LCD STN 128x64 back lighted simultaneous display of: level/flow and temperature, measurement, digital outputs status, recording status and malfunctioning, pump hours of functioning. Last 6 alarms event keyboard (4 digit) for programming
CONTROLLI CONTROLS	6 tasti 6 keys
DATA LOGGER	interno con flash 4 MB Internal flash 4 MB
USCITA SERIALE SERIAL OUTPUT	n.1 RS485 separata galvanicamente isolated
USCITE ANALOGICHE ANALOG OUTPUT	n°2 SEPARATE GALVANICAMENTE PROGRAMMABILI n°2 ISOLATED AND PROGRAMMABLE
USCITA RELÉ RELAY OUTPUT	n°5 per soglie/ripetizione totalizzatore n°1 per allarme (carico max. 1A a 230 VAC resistivo) n°5 per set-point/totalizer repeat n°1 per alarm (max load 1A a 230 VAC resistive)
INGRESSI DIGITALI DIGITAL INPUTS	n°5 programmabili n°5 programmable
ALIMENTAZIONE POWER SUPPLY	90÷260 VAC 50/60 HZ - (optional 24 VAC) isolamento trasformatore transformer isolation 4 KV
CONSUMO MEDIO POWER CONSUPTION	< 12W
CONTENITORE ENCLOSURE	ABS per montaggio parete, IP65, 230x185x120 mm, peso 1,0 Kg ABS wall mounting, IP65, 230x185x120 mm, weight 1,0 Kg



ULTRASONIC SENSOR

ACCURATEZZA ACCURACY	±0,5% V.L.
INSTALLAZIONE MECCANICA PROCESS CONNECTION	1" G.M.
RISOLUZIONE RESOLUTION	0,2 mm
TEMPERATURA LAVORO WORKING TEMPERATURE	-30 ÷ +80 °C
PROTEZIONE/CONNESSIONE ELETTRICA PROTECTION/ELECTRICAL CONNECTION	IP68 con cavo uscente 3 mt IP68 with 3 mt shielded cable
PRESSIONE PRESSURE	0,5 ÷ 1,5 bar
ALIMENTAZIONE POWER SUPPLY	24 VAC, consumo consumption 1W
VISUALIZZAZIONE VISUALIZATION	LED rosso (power-on), LED giallo (eco) LED red (power-on), yellow LED (eco signal)
MATERIALE MATERIAL	PP

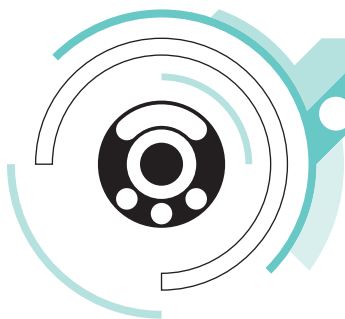

REGISTRAZIONI MISURE - MEASUREMENT RECORDING

INTERVALLO REGISTRAZIONI RECORDING STEPS	portata flow rate 1, 2, 5, 1, 15, 20, 30, 60 min volume totalizzato total volume circolare/riempimento f.i.f.o. or filling
TIPO TYPE	portata flow rate circolare/riempimento f.i.f.o. or filling volume totalizzato total volume circolare/riempimento f.i.f.o. or filling
VISUALIZZAZIONE SHOWING	portata flow rate grafica: valori minimi/massimi e medi del periodo e funzione di zoom volume totalizzato total volume tabellare tabular

USCITE ANALOGICHE - ANALOG OUTPUTS

GRANDEZZA SIZE	portata flow rate portata/temperatura flow/temperature volume totalizzato total volume portata/livello/temperatura flow/level/temperature
TIPOLOGIA TYPOLOGY	programmazione limite: inferiore/superiore limit programming: lower/upper
RANGE	0,00÷20,00 mA / 4,00÷20,00 mA
MASSIMO CARICO MAXIMUM LOAD	500 ohm
USCITA ALLARME ALARM OUTPUT	2,4 mA (range 4÷20 mA)

USCITE ANALOGICHE - ANALOG OUTPUTS

FUNZIONE/PROGRAMMAZIONE FUNCTION/PROGRAMMING	set-point ON/OFF con isteresi with hysteresis impulso pulse demoltiplicatore scaler 1, 10, 100 mc/h durata duration 250, 500, 1.000, 2.000 sec.
--	--

ALLARME ALARM

FUNZIONE FUNCTION	soglie allarme di perdita eco alarm thresholds echo loss
PROGRAMMAZIONE PROGRAMMING	time out (tempo di mancanza eco - echo loss time) 00:00 ÷ 24:00 h

CONDIZIONI DI FUNZIONAMENTO - OPERATING CONDITION

TEMPERATURA, STOCCAGGIO, TRASPORTO TEMPERATURE, STORAGE, TRANSPORT	0÷50°C, -25÷65°C
UMIDITÀ HUMIDITY	10-95% non condensata not condensating
PROTEZIONE PROTECTION DEGREE	chiuso IP65 EN60529, con pannello trasparente aperto IP54 closed IP65 EN60529, with clear open lid IP54
EMI /RFI	CEI-EN55011 - 05/99

CANALE VENTURI - VENTURI CHANNEL

MODELLI MODELS	PORTATE FLOW RATES	
	Qmin	Qmax
CV.150	1 m ³ /h - 0,28 lt/s	50m ³ /h - 13,8 lt/s
CV.200	2 m ³ /h - 0,55 lt/s	55m ³ /h - 17,27 lt/s
CV.300	3 m ³ /h - 0,83 lt/s	150m ³ /h - 41,6 lt/s
CV.400	10 m ³ /h - 2,7 lt/s	310 m ³ /h - 86,1 lt/s
CV.500	20 m ³ /h - 5,5 lt/s	500m ³ /h - 138,8 lt/s
CV.600	25 m ³ /h - 7,5 lt/s	850 m ³ /h - 236 lt/s
CV.800	50 m ³ /h - 13,9 lt/s	1.400m ³ /h - 389 lt/s
CV.1000	60 m ³ /h - 16,6 lt/s	2.250 m ³ /h - 625 lt/s



WATER TREATMENT DIVISION
WM SERIES
CONTATORI PER ACQUA WATER METERS



MODELLI E CARATTERISTICHE TECNICHE MODELS AND TECHNICAL FEATURES

WM.R

- **CONTATORE FILETTATO PER ACQUA FREDDA E CALDA** con emettitore d'Impulsi tipo REED e Lettura di Portata
- **QUADRANTE ASCIUTTO** • **LETTURA A RULLI** • 4 o 1 IMPULSO/LITRO • PER ACQUA FREDDA FINO A 30°C • PER ACQUA CALDA FINO A 90°C • **CONNESSIONI 1/2"÷2" (13mm ÷ 50mm)**

- **THREADED METER FOR COLD/HOT WATER**, Reed Type Pulse Emitter and Flow Rate Reading
- **DRY DIAL** • **ROLLER READING** • 4 or 1 PULSE/LITER • **COLD WATER UP TO 30°C** • **HOT WATER UP TO 90°C** • **1/2"÷2" (13mm ÷ 50mm) CONNECTIONS**

WM.RS

- **CONTATORE FILETTATO PER ACQUA FREDDA** senza Emettitore d'Impulsi, con Lettura di Portata
- **QUADRANTE ASCIUTTO/BAGNATO** • **LETTURA A RULLI** • 4 o 1 IMPULSO/LITRO • PER ACQUA FREDDA FINO A 30°C • PER ACQUA CALDA FINO A 90°C • **CONNESSIONI 1/2"÷2" (13mm ÷ 50mm)**

- **THREADED METER FOR COLD/HOT WATER** without Pulse Emitter, with Flow Rate Reading
- **DRY OR WET DIAL** • **ROLLER READING** • 4 or 1 PULSE/LITER • **COLD WATER UP TO 30°C** • **1/2"÷2" (13mm ÷ 50mm) CONNECTIONS**

WM.F

- **CONTATORE FLANGIATO PER ACQUA FREDDA** con emettitore d'Impulsi e Lettura di Portata, Alta Capacità (fino a 300 m³/h), serie Woltmann
- **QUADRANTE BAGNATO** • **PER ACQUA FREDDA FINO A 50°C** • **CONNESSIONI 2"÷6" (DN50 ÷ DN150)**

- **FLANGED METER FOR COLD WATER** with Pulse Emitter and Flow Rate Reading, High Capacity (up to 300 m³/h), Woltmann Series
- **DRY DIAL** • **COLD WATER UP TO 50°C** • **2"÷6" (DN50 ÷ DN150) CONNECTIONS**



CARATTERISTICHE TECNICHE TECHNICAL FEATURES

WM.RH/WM.RS

Ø POLLICI Ø INCH	Ø mm	PORTATE MAX MAX FLOW RATE	PORTATE NOMINALI NOMINAL FLOW RATES	PORTATE MINIME (ACCURATEZZA ±5%) MINIMUM FLOW RATES (±5% ACCURACY)	PORTATE TRANSIZIONE (ACCURATEZZA ±5%) TRANSITION FLOW RATES (±5% ACCURACY)	FONDO SCALA QUAD. LETTURA MAXIMUM READING
		Q max m³/h	m³/h Qn	Q min lt/h	Q t lt/h	m³
1/2"	13	3	1,5	30	120	10.000
3/4"	20	5	2,5	50	200	10.000
1"	25	7	3,5	70	280	100.000
1" 1/4	30	10	5	100	400	100.000
1" 1/2	40	20	10	200	800	100.000
2"	50	30	15	450	3.000	100.000

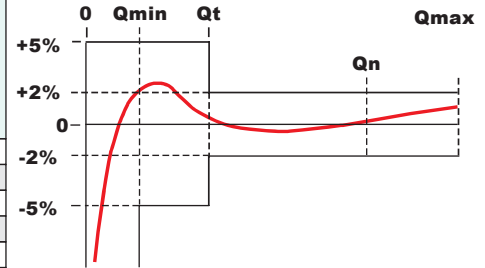

Ø POLLICI Ø INCH	Ø mm	LUNGHEZZA SENZA RACCORDI LENGTH WITHOUT CONNECTIONS	LARGHEZZA WIDTH	ALTEZZA HEIGHT	FONDO SCALA QUAD. LETTURA MAXIMUM READING
		mm	mm	mm	m³
1/2"	13	110	80	90	10.000
3/4"	20	130	80	90	10.000
1"	25	160	100	120	100.000
1" 1/4	30	160	100	120	100.000
1" 1/2	40	200	110	130	100.000
2"	50	300	152	200	100.000



آتور صنعت
ATOORSANAT

WM.F

Ø POLLICI Ø INCH	Ø mm	PORTATE MAX MAX FLOW RATE	PORTATE CON 1m DI PERDITA DI CARICO FLOW RATE WITH 1m LOSS CHARGE	PORTATE NOMINALI NOMINAL FLOW RATES	PORTATE MINIME (ACCURATEZZA ±5%) MINIMUM FLOW RATES (±5% ACCURACY)	PORTATE TRANSIZIONE (ACCURATEZZA ±5%) TRANSITION FLOW RATES (±5% ACCURACY)
		Q max m³/h	m³/h Qn	Qn m³/h	Q min m³/h	Qt m³/h
2"	50	30	20	15	1,2	1,5
2" 1/2	65	50	55	25	3	7,5
3"	80	80	65	40	3,2	12
4"	100	120	120	60	4,8	18
6"	150	300	300	150	12	45

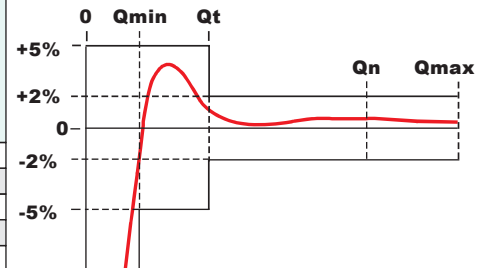

Ø POLLICI Ø INCH	DN	LUNGHEZZA LENGTH	LARGHEZZA WIDTH	ALTEZZA HEIGHT	FONDO SCALA QUAD. LETTURA MAXIMUM READING
		mm	mm	mm	Ø mm N° mm
2"	50	200	165	247	18 4 125
2" 1/2	65	200	185	258	18 4 15
3"	80	200	200	265	18 4 160
4"	100	250	220	272	18 8 180
6"	150	300	285	302	22 8 240



CARATTERISTICHE GENERALI GENERAL FEATURES

VELOCI FAST

- **ADATTI PER LIQUIDI CON VISCOSITÀ MOLTO BASSA, SU SERBATOI O BACINI DI CAPACITÀ MEDIA, PER LA MISCELAZIONE DI REATTIVI CHIMICI O PER LA PREPARAZIONE DI SOLUZIONI**
- **GEOMETRIA DELL'ELICA**
 - Migliore Miscelazione - Potenza Richiesta Inferiore - Aspirazione dell'Additivo Miscelato dal fondo del Serbatoi con Minori Vibrazioni
- **CONNESSIONE DEL MOTORE**
 - L'Albero è Maggiormente Bilanciato (Riduzione Delle Vibrazioni) - I Modelli in PVC sono rivestiti di Resina Epossidica per una migliore Resistenza Chimica e con un minor numero di Componenti in Rotazione (Riduzione dell'Usura)
- **SUITABLE FOR LIQUID WITH VERY LOW VISCOSITY, ON TANK OR BASINS OF MEDIUM CAPACITY, FOR THE MIXING OF CHEMICAL REAGENTS OR FOR THE PREPARATION OF SOLUTIONS**
- **GEOMETRY OF THE PROPELLER**
 - Better Mixing - Less Power Required - Aspiration of the Mixed Additive done directly on the Botton of the Tank with Smaller Vibration
- **CONNECTION OF THE MOTOR**
 - Shaft is better Balanced (Reduction of the Vibrations) - The PVC Models are coated with Epoxy Resin for a better Chemical Resistance, and with a smaller Number of the Components in Rotation (Reduction of the Usury)

LENTI SLOW

- **ADATTI NEL SETTORE DEL TRATTAMENTO ACQUE PER FLOCCULAZIONE E PREPARAZIONE DI POLIELETTROLITI**
- **GEOMETRIA DELL'ELICA**
 - Pale dell'Elica in PVC Intercambiabili - Possibilità di aggiungere altre Pale sull'Elica per Applicazioni Speciali (vendute separatamente in Kit di Montaggio) - Possibilità di aggiungere una seconda Elica sull'Albero per una Migliore Agitazione con i Solidi in Sospensione (vendute separatamente in Kit di Montaggio)
- **CONNESSIONE DEL MOTORE**
 - La Velocità degli Agitatori Lenti cambia da 70 giri/min (Optional) a 200 giri/min (Standard) - I Motori Elettrici sono del tutto Intercambiabili su tutta la Gamma (0,12÷0,37 Kw)
- **SUITABLE FOR THE SECTOR OF THE WATER TREATMENT FOR FLOCCULANTS AND FOR THE PREPARATION OF POLYELECTROLYTE**
- **GEOMETRY OF THE PROPELLER**
 - Blades of the Helix in PVC (replaceable) - Possibility to add Other Blades on the Propeller for Special Applications (sold separately in Assembly Kit) - Possibility to add a second Propeller on the Shaft for a Better Mixing of the Suspended Solids (sold separately in Assembly Kit)
- **CONNECTION OF THE MOTOR**
 - The Speed of the Electrical Motors changes from 70 turns/min (Optional) to 200 turns/min (Standard) - The Motors are completely Interchangeable (0,12÷0,37 Kws)



CARATTERISTICHE GENERALI - GENERAL FEATURES



MX.V VELOCI FAST

- MOTORE MONOFASE/TRIFASE, IP65, 0,12 kW - 4 POLI (altre potenze disponibili su richiesta)
- ALBERO IN PVC / AISI316L, LUNGHEZZE 600, 800, 900, 1100 mm (altre lunghezze disponibili su richiesta)
- ELICA IN PVC / AISI316L, 2 PALE, DIAMETRO 90 mm (altri diametri disponibili su richiesta)
- SINGLEPHASE/THREEPHASE MOTOR, IP65, 0,12kW-4 POLES (other power supplies available upon request)
- PVC/SS316L SHAFT, LENGTH 600, 800, 900, 1100 mm (other lengths available upon request)
- PVC/SS316L PROPELLER, 2 BLADES, DIAMETER 90 mm (other lengths diameters upon request)

آتور صنعت
ATOORSANAT



MX.L LENTI SLOW

- MOTORE+RIDUTTORE MONOFASE/TRIFASE, IP65, 0,12 kW - 4 POLI (altre potenze disponibili su richiesta), RAPPORTO DI RIDUZIONE 1:7-200 rpm (Standard), 1:20-70 rpm (Optional)
- ALBERO IN PVC / AISI316L, LUNGHEZZE 600, 800, 900, 1100 mm (altre lunghezze disponibili su richiesta)
- ELICA IN PVC / AISI316L, 2, 3, 6 PALE (piane o forate), DIAMETRO 90, 150, 220 mm (altri diametri disponibili su richiesta)
- SINGLEPHASE / THREEPHASE MOTOR + REDUCER, IP65, 0,12kW-4 POLES (other power supplies available upon request), REDUCER RATIO 1:7-200 rpm (Standard), 1:20-70 rpm (Optional)
- PVC/SS316L SHAFT, LENGTH 600, 800, 900, 1100 mm (other lengths available upon request)
- PVC/SS316L PROPELLER, 2, 3, 6 BLADES (flat or with holes), DIAMETER 90, 150, 220 mm (other lengths diameters upon request)



SELEZIONE DEL MASSIMO VOLUME IN VASCA SELECTION OF THE MAXIMUM VOLUME IN THE TANKS

	VELOCI FAST	LENTI SLOW
MISCELATORE SEMPLICE SIMPLE MIXING	5 m ³	70 m ³
PREPARAZIONE REAGENTI REAGENT PREPARATION	3 m ³	30 m ³
NEUTRALIZZAZIONE NEUTRALIZATION	2 m ³	20 m ³
SOSPENSIONE FANGHI SLUDGES SUSPENSION (50÷80 g/l)	1,7 m ³	15 m ³
LATTE DI CALCE LIME MILK (50÷80 g/l)	1,7 m ³	15 m ³
(100÷200 g/l)	-	15 m ³
POLIELETTROLITA POLYELETTROLYTE (50÷80 g/l)	-	15 m ³

POSIZIONAMENTO AGITATORE INSTALLATION OF THE MIXER

G>100 - VELOCI FAST / G>100 - LENTI SLOW

N.B. in caso di montaggio centrale occorre predisporre 3 pale antirotazione a 120° per gli agitatori veloci e 4 pale per agitatori lenti

P.N. in case of central installation is necessary to have 3 anti-spin blades at 120° for the fast mixers and 4 blades for the slow mixers

- A - altezza liquido liquid height
- B - diametro serbatoio tank diameter
- C - distanza dell'elica dal fondo distance of the propeller from the bottom
- D - distanza tra le 2 eliche distance between the 2 propellers
- E - diametro elica propeller diameter
- per for $0,5 < A/B < 1,1$ 1 elica propeller $C = 0,5 \div 2 \times E$
- per for $1,1 < A/B < 1,6$ 2 eliche propellers $D = 5 \div E$ (VELOCI FAST)
 $D = 2 \div E$ (LENTI SLOW)

SCELTA DEL DIAMETRO DELL'ELICA IN FUNZIONE DEL SERBATOIO
SELECTION OF THE DIAMETER OF THE PROPELLER ACCORDING TO THE TANK

$E = B \div 0,2$ (VELOCI FAST) $E = B \div 0,3$ (LENTI SLOW)

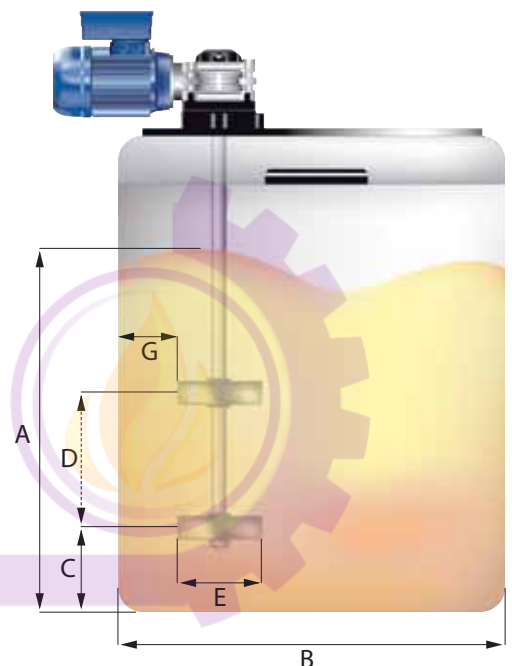

VERIFICA DELLA POTENZA DEL MOTORE VERIFICATION OF THE POWER OF THE MOTOR

gli agitatori sono forniti di un motore adeguatamente dimensionato. Per il calcolo della potenza necessaria occorre moltiplicare
the mixers are supplied with an appropriate motor. For the calculation of the needed power it is necessary to multiply:

- $P_{reale\ real} = P_{usata\ used} \times \text{densità liquido density of the liquid} \times \text{coefficiente di viscosità coefficient of viscosity}$ ($P_{reale\ real} = \text{potenza in acqua power in water}$)
è necessario verificare che la potenza del motore sia it is necessary to verify that the power of the motor is:
- $= P_{reale\ real} + 5\%$ (VELOCI FAST) ● $= P_{reale\ real} + 25\%$ (LENTI SLOW)

occorre tenere presente che it is necessary to keep in mind that:

- aumentando del 50% la velocità occorre aumentare la potenza di ~ 3 volte increasing of 50% of the speed means that you have to increase the power of ~ 3 times
- aumentando del 50% il diametro dell'elica occorre aumentare la potenza di 7 ~ volte increasing of 50% of the diameter of the propeller means that you have to increase the power of 7 times

ESEMPIO EXAMPLE:

950 rpm occorre con elica Ø120 e motore 0,25 kW 950 rpm is necessary to use 0,25 KW motor

- per andare a 1400 rpm occorre scegliere un motore da 1 kW to go to 1400 rpm it is necessary to use 1 kW motor
- per usare un'elica da 180 occorre scegliere un motore da 1,5 kW to use a propeller of 180 it is necessary to use 1,5 kW motor



ACCESSORY PRODUCTS

AC.LA SERIES

LANCE DI ASPIRAZIONE CON FILTRO DI FONDO SUCTION LANCES WITH FOOT FILTER

- Disponibili versioni con sonda di livello • Tenute in FPM (EPDM su richiesta) • Realizzate in PVC/PP con tubo di aspirazione in PVC Crystal • Tutte le lance sono dotate di valvola di fondo

- Available with level probe • FPM seals (EPDM upon request) • Made of PVC/PP with PVC Crystal suction tube • All the suction lances are equipped with foot valves

MODELLI MODELS	DIMENSIONI DIMENSIONS	TUBI TUBES	per SERBATOI for TANKS
AC.LA 05	450x22mm	4x6	50 lt
	450x34mm	8x12	50 lt
AC.LA 1	650x22mm	4x6	100 lt
	650x34mm	8x12	100 lt
AC.LA 2	900x22mm	4x6	250 lt
	900x34mm	8x12	250 lt
AC.LA 3	1050x22mm	4x6	300 lt
	1050x34mm	8x12	300 lt
AC.LA 5/10	1250x22mm	4x6	500/1000 lt
	1250x34mm	8x12	500/1000 lt

AC.SE SERIES

SERBATOI IN POLIETILENE POLYETHYLENE TANKS

- Studiati per l'assemblaggio di gruppi di dosaggio con agitatori, pompe dosatrici elettromeccaniche ed elettromagnetiche. Garantiscono un'elevata resistenza meccanica ottenuta per centrifugazione. Sono compatibili a tutti i prodotti chimici utilizzati per gli impianti di dosaggio

- Suggested for the assembling of dosing groups with mixers, electromechanic and electromagnetic dosing pumps. They grant a high mechanical resistance obtained through centrifugal. Force compatible with all chemicals used in the dosing groups

MODELLI MODELS	CAPACITÀ CAPACITY	ALTEZZE HEIGHTS	DIAMETRI DIAMETERS
AC.LA 05	50 lt	455 mm	40 cm
AC.LA 1	100 lt	640 mm	45 cm
AC.LA 2	250 lt	870 mm	60 cm
AC.LA 3	300 lt	950 mm	67 cm
AC.LA 5	500 lt	1185 mm	76 cm
AC.LA 10	1000 lt	122 mm	108,5 cm

AC.VA SERIES

- Vasche di contenimento a cielo aperto in polietilene progettate esclusivamente per l'utilizzo dei nostri serbatoi

- Polyethylene uncovered tanks, designed to contain our tank

MODELLI MODELS	CAPACITÀ CAPACITY	ALTEZZE HEIGHTS	DIAMETRI DIAMETER
AC.VA 1	150 lt	755 mm	510 mm
AC.VA 2	300 lt	875 mm	670 mm
AC.VA 3	400 lt	990 mm	720 mm
AC.VA 5	800 lt	1200 mm	900 mm
AC.VA 10	1500 lt	1340 mm	1220 mm

AC.SU SERIES

- Piastre di supporto in PVC progettate e dimensionate per montaggio agitatori e pompe dosatrici su serbatoi

- Re-inforced PVC tanks to be used for installing mixers and motor driven or solenoid dosing pumps

MODELLI MODELS	per SERBATOI for TANKS	ALTEZZE HEIGHTS
AC.SU 1	AC.SE 1	20 mm
AC.SU 2	AC.SE 2	20 mm
AC.SU 3	AC.SE 3	20 mm
AC.SU 5	AC.SE 5	20 mm
AC.SU 10	AC.SE 10	20 mm

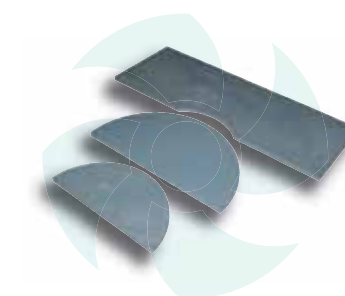



READING & MEASUREMENT

SENSORI, SONDE E CELLE SENSORS, PROBE AND CELLS



E.pH/Rx

MODELLI MODELS	RANGE	CONNESSIONI CONNECTIONS	TEMPERATURA TEMPERATURE	MATERIALE MATERIAL	PRESSIONE MAX MAX PRESSURE
E.PH	0 ÷ 14 pH	cavo cable 1,5m+BNC	60°C	epoxy	7 bar
E.PH 1	0 ÷ 14 pH	cavo cable 6m+BNC	60°C	epoxy	7 bar
E.RX	±1000 mV	cavo cable 1,5m+BNC	60°C	epoxy	7 bar
E.RX 1	±1000 mV	cavo cable 6m+BNC	60°C	epoxy	7 bar
E.PH V	0 ÷ 14 pH	attacco a vite screw connections S7	90°C	vetro glass	7 bar
E.RX V	±1000 mV	attacco a vite screw connections S7	90°C	vetro glass	7 bar
E.PH HT	0 ÷ 14 pH	attacco a vite screw connections S7	130°C	vetro glass	7 bar
E.RX HT	±1000 mV	attacco a vite screw connections S7	130°C	vetro glass	7 bar

<http://goo.gl/Z9JZOb>

E.CD CONDUCIBILITÀ CONDUCTIVITY

MODELLI MODELS	RANGE	ELETTRODI ELECTRODES	CONNESSIONI CONNECTIONS	TEMPERATURA TEMPERATURE	MATERIALE MATERIAL
E.CD K1	1 ÷ 5000 μS	SS316	cavo cable 5m 1/2"	80°C	PP
E.CD K5	0,1 ÷ 1000 μS	SS316	cavo cable 5m 1/2"	80°C	PP
E.CD K10	0,01 ÷ 500 μS	SS316	cavo cable 5m 1/2"	80°C	PP
E.CD K1 GR	0 ÷ 20000 μS	Grafite	cavo cable 5m 1/2"	80°C	PP
E.CT K1 GR	0 ÷ 20000 μS	Grafite+T°	cavo cable 5m 1/2"	80°C	PP
E.CT K1 SS	0 ÷ 20000 μS	SS316+PTFE	cavo cable 5m 1"	80°C	PP
E.CT K1 GR	5 ÷ 20000 μS	Grafite	cavo cable 5m 1"	50°C	Pvc
E.CD K1 PT	0 ÷ 20000 μS	Platinum	Ø 12mm cable 6m	130°C	Glass

CTK.1 CONDUCIBILITÀ+TEMPERATURA CONDUCTIVITY+TEMPERATURE

RANGE	COSTANTE CONSTANT	TEMPERATURA TEMPERATURE	PRESSIONE PRESSURE	ELETTRODI ELECTRODES	MATERIALE MATERIAL	MONTAGGIO MOUNTING	PROTEZIONE PROTECTION DEGREE
5 ÷ 5000 μS	C=1 cm ⁻¹ K=1 cm	100°C	6 bar	SS316L	PP	3/4" GAS M	IP65

CTK.5 CONDUCIBILITÀ+TEMPERATURA CONDUCTIVITY+TEMPERATURE

RANGE	COSTANTE CONSTANT	TEMPERATURA TEMPERATURE	PRESSIONE PRESSURE	ELETTRODI ELECTRODES	MATERIALE MATERIAL	MONTAGGIO MOUNTING	PROTEZIONE PROTECTION DEGREE
0,5 ÷ 5000 μS	C=0,2 cm ⁻¹ K=5 cm	100°C	6 bar	SS316L	PP	3/4" GAS M	IP65



ACCESSORY PRODUCTS

CTK.10 CONDUCTIBILITÀ+TEMPERATURA CONDUCTIVITY+TEMPERATURE

RANGE	COSTANTE CONSTANT	TEMPERATURA TEMPERATURE	PRESSIONE PRESSURE	ELETTRODI ELECTRODES	MATERIALE MATERIAL	MONTAGGIO MOUNTING	PROTEZIONE PROTECTION DEGREE
0,01÷500 μ S	C=0,1 cm ⁻¹ K=10 cm	100°C	6 bar	SS316L	PP	3/4" GAS M	IP65

CAVO PER SENSORE CONDUCTIBILITÀ CABLE FOR CONDUCTIVITY SENSOR

TIPO TYPE	LUNGHEZZE LENGTHS	N° POLI N° POLES	VERSIONE VERSION
cavo 5 poli (3 PT100, 2 sensori) con schermo e guaina completa in PVC con connettore femmina	5/10/15 mt	4	standard

E.OX OSSIGENO OXYGEN

RANGE TEMPERATURA TEMPERATURE RANGE	-10÷60°C con acqua contenuta nel portasonda -10÷60°C with water contained in a probe holder
TEMPERATURA LAVORO WORKING TEMPERATURE	0÷60°C
PRESSIONE PRESSURE	0÷4 bar inserita in condotta - 0,5 bar totalmente immersa 0÷4 bar inserted in pipe - 0,5 bar totally submerged
ELETTROLITA ELECTROLYTE	soluzione Alcalina Alkaline solution
MATERIALE MATERIAL	Argento-Platino Silver-Platinum
PORTATA FLOW	0,03 m/sec minimum
MONTAGGIO MOUNTING	PG 13,5 mm
CAVO CABLE	5 mt

E.PT TEMPERATURA TEMPERATURE

MODELLI MODELS	PRESSIONE PRESSURE	MATERIALE MATERIAL	CONNESSIONI CONNECTIONS	CAVO CABLE
E.PT 100 V	-	Pyrex	standard Ø12	5m - 3 wire
E.PT 100 NUT	-	PVC	1/2" GAS	1m - 2 wire

MODELLI MODELS	PRESSIONE PRESSURE	MATERIALE MATERIAL	CORPO BODY	CAVO CABLE
E.PT NTC	7 bar	SS304	12x100 mm (Ø-L)	3 m

MODELLI
MODELS

E.PT RNC Soppressore disturbi elettrici, consente l'eliminazione di Correnti Passive, AISI304 - Ø12 mm
Electrical Surge Suppressor, allows the elimination of eddy currents, AISI304 - Ø12 mm



E.FLOW

• **SENSORE PER IL RILIEVO FLUSSO IDRAULICO CON ALTA PRESSIONE DI CONTEGGIO**

• **SENSOR FOR HIGH PRECISION AND MEASUREMENT OF HYDRAULIC FLOW**

MATERIALE MATERIAL	VELOCITÀ FLUIDO FLOW SPEED	PRESSIONE PRESSURE	CONNESSIONI CONNECTIONS
PVC / SS316L	0,15÷8 m/s	10bar 25°C (PVC), 25bar 120° (SS316L)	DN15÷DN100 / DN150÷DN200



staffa portasonda in PVC
Ø DN50÷DN500
PVC probe holder bracket
Ø DN50÷DN500



raccordo a "T" in PVC
Ø DN15÷DN40
"T" PVC connection
Ø DN15÷DN40

EL.FLOW

• **SENSORE ELETTROMAGNETICO**

• **ELECTROMAGNETIC SENSOR**

MATERIALE MATERIAL	VELOCITÀ FLUIDO FLOW SPEED	PRESSIONE PRESSURE	CONNESSIONI CONNECTIONS
SS316L	0,15÷5 m/s	16bar 25°C	DN15÷DN100 / DN150÷DN200



staffa portasonda in PVC Ø DN50÷DN200
PVC probe holder bracket Ø DN50÷DN200

EL.FLOWCHECK SENSORE DI FLUSSO FLOW SENSOR

• **MODULO IDRAULICO CON SENSORE REED**, grazie ad un galleggiante magnetico di colore rosso è possibile chiudere il Reed quando il flusso d'acqua non è presente e la pompa dosatrice si bloccherà

• **HYDRAULIC FLOW CHECK DEVICE WITH REED SENSOR**, through a magnetic red flow rate is not present and the dosing pump will be stopped





ACCESSORY PRODUCTS

DCL.04 SERIES

PORTASONDA PROBE-HOLDERS

pH, Redox



- 1 misuratore di portata
- 1 o 2 portasonda \varnothing 12mm (pH/Redox)
- IN 8x12 mm
- OUT 8x12 mm
- rubinetto
- 139x180x55 mm
- 1,0 Kg
- 1 Flow meter
- 1 or 2 \varnothing 12mm (pH/Redox) probe-holders
- IN 8x12 mm
- OUT 8x12 mm
- Valve
- 139x180x55 mm
- 1,0 Kg

Altri modelli disponibili: solo pH
Other available models: pH only

pH, Redox, CL Amperometrico



- 1 misuratore di portata
- 1 portasonda \varnothing 12mm (pH/Redox)
- 1 portasonda Cloro Amperometrico
- IN 8x12 mm
- OUT 8x12 mm
- rubinetto
- 139x180x55 mm
- 1,2 Kg
- 1 Flow meter
- 1 \varnothing 12mm (pH/Redox) probe-holder
- 1 Amperometric Chlorine probe-holder
- IN 8x12 mm
- OUT 8x12 mm
- Valve
- 139x180x55 mm
- 1,2 Kg

Altri modelli disponibili: solo Cl Amperometrico, pH e Cl Amperometrico,
pH e Cl Potenzistatico

Other available models: Amperometric Chlorine only, pH and Amperometric Chlorine

pH, Redox, CL Potenzistatico



- 1 misuratore di portata
- 2 portasonda \varnothing 12mm (pH/Redox)
- 1 portasonda \varnothing 24mm (pH/Redox)
- IN 8x12 mm
- OUT 8x12 mm
- rubinetto
- 139x230x55 mm
- 1,2 Kg
- 1 Flow meter
- 2 \varnothing 12mm (pH/Redox) probe-holder
- 1 \varnothing 24mm (pH/Redox) probe-holder
- IN 8x12 mm
- OUT 8x12 mm
- Valve
- 139x230x55 mm
- 1,2 Kg

Altri modelli disponibili: solo Cl Potenzistatico, pH/Rx Cl Amperometrico,
CL1 Amperometrico CL2 Potenzistatico

Other available models: Potentiostatic Chlorine only, pH/Rx and Amperometric Chlorine,
CL1 Amperometric CL2 Potentiostatic



READING & MEASUREMENT

SENSORI, SONDE E CELLE SENSORS, PROBE AND CELLS



CARATTERISTICHE GENERALI GENERAL FEATURES

D.CLP CLORO CHLORINE

- **SENSORE POTENZIOSTATICO** per la misura del **CLORO LIBERO O TOTALE**
- **POTENTIOSTATIC SENSOR** for the measure of **FREE OR TOTAL CHLORINE**



آتور صنعت
ATOORSANAT



CARATTERISTICHE TECNICHE TECHNICAL FEATURES

MODELLI MODELS	D.CLP 01 I cloro libero inorganico free inorganic chlorine	D.CLP 02 O cloro libero organico free organic chlorine	D.CLP 03 I cloro libero inorganico free inorganic chlorine	D.CLP 04 I cloro libero inorganico free inorganic chlorine	D.CLP 05 I cloro libero inorganico free inorganic chlorine	D.CLP 06 I cloro libero inorganico free inorganic chlorine	D.CLP 07 I cloro libero inorganico free inorganic chlorine	D.CLP 08 I cloro libero inorganico free inorganic chlorine	D.CLP 09 I cloro libero inorganico free inorganic chlorine	D.CTO I cloro totale total chlorine	D.BC 01 biossido di cloro chlorine dioxide
RANGE (ppm)	0÷10	0÷10	0÷10	0÷200	0÷2	0÷1	0÷5	0÷1	0÷5	0÷10	0÷10
RANGE pH	4÷8	4÷12	4÷11	4÷8	4÷8	5÷9	5÷9	5÷9	5÷9	0÷14	0÷14
RISOLUZIONE RESOLUTION (ppm)	±0,01	±0,01	±0,01	±0,01	±0,01	±0,01	±0,01	±0,01	±0,01	±0,01	±0,01
TEMPERATURA TEMPERATURE	45°C	45°C	45°C	45°C	45°C	50°C	50°C	70°C	70°C	70°C	45°C
PRESSIONE PRESSURE	1 bar	0,5 bar	0,5 bar	0,5 bar	0,5 bar	5 bar	5 bar	8 bar	8 bar	0,5 bar	0,5 bar
MEMBRANE DIAPHRAGMS	M.01	M.02	M.03	M.03	M.03	M.03	M.03	M.03	M.03	M.CTO	M.BC
ELETTROLITI ELECTROLYTES	E.CLI 01	E.CLI 02	E.CLI 03	E.CLI 03	E.CLI 03	E.CLI 03	E.CLI 03	E.CLI 03	E.CLI 03	E.CTO	E.BC
TENSIONE VOLTAGE	12÷30 VAC										
PORTATA FLOW RATE	≥30 lt/h (tempo stabilizzazione in media 15 min, massimo 1 ora stabilization time average 15 min, max 1 hour)										
USCITA SEGNALE SIGNAL OUTPUTS	4÷20 mA (uscita segnale corente proporzionale alla misura output of current signal proportional to the measurement)										
CAVO CABLE	max 15 m										
MATERIALE MATERIAL	PVC										
DIMENSIONI DIMENSIONS	225 x 25 mm (HxD)										



DESCRIZIONE E CARATTERISTICHE FEATURES AND SPECS

La serie di sensori induttivi CD IND è stata ingegnerizzata e sviluppata per produrre un elettrodo che fosse molto performante, ma allo stesso tempo competitivo. Il risultato è stato ottenuto mediante lo stampaggio del sensore in propilene caricato con fibra di vetro.

Questo sensore offre tutti i vantaggi del metodo di misura della conducibilità induttiva, incluso quello dell'assenza di passivazione dei convenzionali elettrodi di conducibilità. Tutti i sensori della serie CD IND sono compensati in temperatura e sono inoltre progettati per l'installazione in linea, ad immersione o sui serbatoi.

The CD IND series of inductive sensors has been engineered and developed to produce an electrode that is very powerful but at the same time very competitive. The result has been obtained by moulding the sensor made using polypropylene reinforced with fiberglass.

This sensor offers all the advantages of the inductive cond. measurement method, including the absence of passivation of the conventional conductivity electrodes. All the sensors in the CD IND range are temperature-compensated, and are also designed for inline, submersion

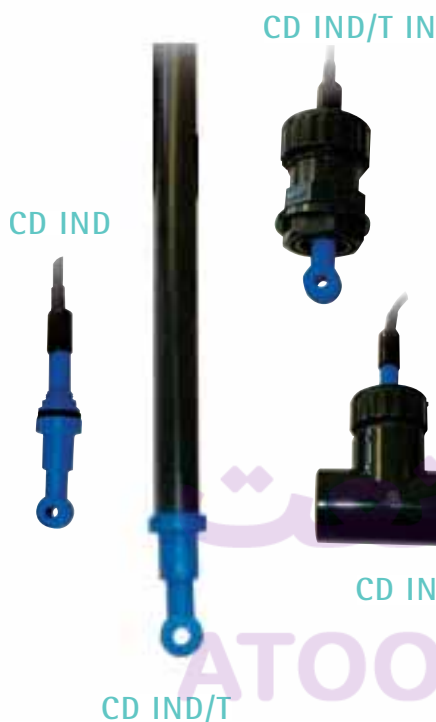

CARATTERISTICHE TECNICHE TECHNICAL FEATURES

TEMPERATURA TEMPERATURE	-5 a 60 °C (senza congelamento)	-5 to 60°C (without freezing)
MATERIALE A CONTATTO CONTACT MATERIAL	polipropilene rinforzato con vetro	Glass-reinforced polypropylene
COMPENSAZIONE TEMPERATURA TEMP. COMPENSATION	fili PT1000	PT1000 wires
CAVO CABLE	Standard 5 metri	Standard 5 metres
CONNESSIONE CONNECTION	1/2" BSP maschio	1/2" BSP male
GRADO DI PROTEZIONE PROTECTION RATING	IP67	IP67
MATERIALE MATERIALS	PVC con guarnizioni in Viton	PVC with Viton gaskets
TEMPERATURA DI ESERCIZIO OPERATING TEMP	-5 a 60 °C (senza congelamento)	-5 TO 60°C (without freezing)
LUNGHEZZA IMMERSIONE SUBMERSION LENGHT	600 o 1200 mm	600 or 1200 mm
MONTAGGIO ASSEMBLY	staffa standard o flangia opzionale	Standard bracket or optional flange
PRESSIONE DI ESERCIZIO OPERATING PRESSURE	da vuoto a 6.5 bar (100 psi)	From vacuum to 6.5 bar (100 psi)
SCALA DI CONDUCIBILITA' CONDUCTIVITY RANGE	1000 µS a 1 Simens	1000 µS to 1 Simens
RISOLUZIONE RESOLUTION	100 µS a 1000 µS	100 µS to 1000 µS



READING & MEASUREMENT

SENSORI, SONDE E CELLE SENSORS, PROBE AND CELLS



CARATTERISTICHE GENERALI GENERAL FEATURES

EC.T S TORBIDITÀ TURBIDITY

- **SENSORE** per la misura ottica di **TORBIDITÀ IN ACQUE PURE E DI PROCESSO** fino a 4000 NTU (SOLIDI SOSPESI)
- Solo per **NEXUS.TBSERIES**
- Applicazioni **ACQUE DI SCARICO, ACQUE PRIMARIE, ACQUE INDUSTRIALI, ACQUE DI RICIRCOLO**
- Elevata affidabilità della misura grazie all'utilizzo della **TECNOLOGIA OTTICA ALL'INFRAROSSO (880 mm)**
- **METODO DELLO SCATTERING A 90° PER LA TORBIDITÀ**
- **ASSENZA DI PARTI MECCANICHE IN MOVIMENTO**
- **MISURA PRE-PROCESSATA NEL SENSORE** che fornisce alta sensibilità nella trasmissione in basso segnale
- **SENSOR** is used for **OPTICAL TURBIDITY IN PURE AND PROCESS WATER** up to 4000 NTU (SUSPENDED SOLIDS)
- Only for **NEXUS.TBSERIES**
- Applications: **WASTEWATER, PRIMARY WATER, INDUSTRIAL WATER, RECIRCULATING WATER**
- Reliable concentration measurement using **OPTICAL MEASURING PROCESS (880 mm)**
- **90° SCATTERING LIGHT METHOD**
- **NO MECHANICALLY MOVING PARTS**
- **MEASURED VALUE PRE-PROCESSING IN SENSOR** resulting in low signal transmission sensitivity

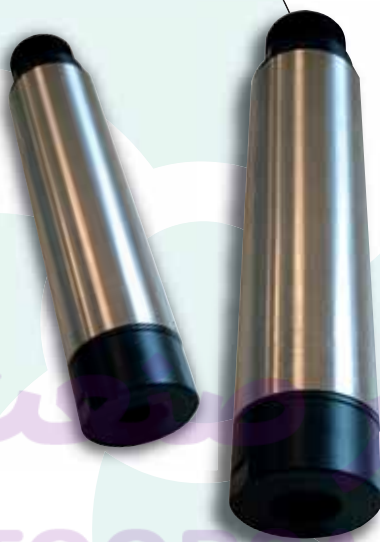

CARATTERISTICHE TECNICHE TECHNICAL FEATURES

RANGE	0÷4/0÷40/0÷400/0÷4000 NTU
FILETTATURA THREAD	1" GAS
ACCURATEZZA ACCURACY	±3% F.S.
RIPETIBILITÀ REPEATABILITY	98%
CALIBRAZIONE CALIBRATION	per punti points
TEMPERATURA TEMPERATURE	0÷60 °C
PRESSIONE MAX MAX PRESSURE	4 bar
MATERIALE MATERIAL	AISI316, Ottica in Vetro Speciale o in Viton SS316, Special Optical Glass or Viton
PROTEZIONE PROTECTION DEGREE	IP68 (cavo incluso included cable)
LUNGHEZZA CAVO CABLE LENGHT	10 m
USCITA OUTPUT	RS485
DIMENSIONI DIMENSIONS	Ø 42x230 mm



CARATTERISTICHE GENERALI - GENERAL FEATURES

E.CT 1/ 2 TORBIDITÀ TURBIDITY

- CELLE di misura **TORBIDIMETRICHE A DEFLUSSO** • Solo per **NEXUS.TBSERIES**
 - Applicazioni **IMPIANTI DI POTABILIZZAZIONE** (all'uscita dalle sezioni di filtrazione e decantazione), **IMPIANTI DI AFFINAMENTO DEI REFLUI PER RIUTILIZZO AGRICOLO O INDUSTRIALE, INDUSTRIA ALIMENTARE** (bevande), **PISCINA**
 - Il principio di misura è quello della **DEVIAZIONE DI LUCE PRODOTTA DALLE PARTICELLE IN SOSPENSIONE** presenti nel liquido
 - Grazie al sistema a **DOPPIO SENSORE** è possibile effettuare misure di **TORBIDITÀ A BASSE CONCENTRAZIONI** con elevata precisione e ripetibilità
 - Le celle sono **INSTALLABILI DIRETTAMENTE IN LINEA** o **SU TUBAZIONE DI BY-PASS**
 - **LA VELOCITÀ DEL FLUSSO NON INTERFERISCE SULLA MISURA**
- **OUTFLOW TURBIDITY MEASUREMENT CELLS** • Only for **NEXUS.TBSERIES**
 - Applications: **WATER TREATMENT PLANT** (downstream of filtration and decantation process section), **AGING FACILITIES OF WASTEWATER REUSE FOR AGRICULTURAL OR INDUSTRIAL PURPOSES, FOOD INDUSTRY** (beverages), **SWIMMING POOL**
 - The principle of measurement is the **DEVIATION OF LIGHT PRODUCED BY SUSPENDED PARTICLES** in the liquid
 - Thanks to the **DUAL SENSOR** is possible to make measurement of **TURBIDITY AT LOW CONCENTRATIONS** with high accuracy and repeatability
 - The cells is **INSTALLED DIRECTLY IN LINE, PIPE or BY-PASS**
 - **THE FLOW VELOCITY DOES NOT AFFECT THE MEASUREMENT**



آتور صنعت
ATOORSANAT

CARATTERISTICHE TECNICHE - TECHNICAL FEATURES

	E.CT 1 (AISI SS)	E.CT 2 (PVC)
RANGE	0,01 ÷ 100 FTU	0,01 ÷ 100 FTU
PRESSIONE MAX - MAX PRESSURE	6 bar	6 bar
TEMPERATURA MAX - MAX TEMPERATURE	90°C	45°C
MATERIALE - MATERIAL	AISI316L, attacchi filettati 2"1/2" M, rivestimento interno in PTFE nero, Oblò in vetro temperato SS316L, 2"1/2 M threaded connections, Black PTFE internal coating, Tempered glass door	PVC nero, attacchi filettati 2"1/2" F Oblò in PVC trasparente Black PVC, 2"1/2 F threaded connections Transparent PVC door



WATER TREATMENT DIVISION PSD4 SERIES

PORTASONDA A DEFLUSSO
HOUSING PROBE HOLDER BYPASS CONNECTION



CARATTERISTICHE GENERALI GENERAL FEATURES



La serie di portasonda PSD4 è un alloggiamento avanzato per connessioni idrauliche a deflusso.

L'elettrodo sempre in contatto con il fluido garantisce la migliore affidabilità della misurazione.

Grazie alla presenza di 4 modelli diversi, ogni bisogno viene soddisfatto

The PSD4 probe holder Series is an advanced housing for by-pass hydraulic connection. Electrode always in contact with the fluid, assures the best accuracy in readings. All needs satisfied with 4 different models.

ALLOGGIAMENTI SONDE HOUSING FOR PROBES

- pH (12mm)
- ORP (Redox) (12mm)
- Conduttività (12mm)
- Cloro (24mm)
- Ossigeno (35mm)
- Torbidità (42mm)

- pH (12mm)
- ORP (Redox) (12mm)
- Conductivity (12mm)
- Chlorine (24mm)
- Oxygen (35mm)
- Turbidity (42mm)

APPLICAZIONI APPLICATIONS

- Acque reflue
- Acque potabili
- Torri raffreddamento
- Osmosi inversa
- Irrigazione
- Piscine

- Waste water
- Drinking water
- Cooling Towers
- Reverse Osmosis
- Irrigation
- Swimming pool

CARATTERISTICHE FEATURES

- Portasonda a deflusso fino a 5 bar
Temperature di esercizio fino a 50°C
- Connessione idraulica rapida attraverso dado di tenuta
- Controllo del flusso attraverso sensore Reed ad apertura alla pressione minima di 0,5 bar
- Versione montabile a parete attraverso piastra inclusa

- Housing By-Pass probe holder pressure up to 5 bar
Temperature up to 50°C
- Hydraulic connection via fast connection with clamping nut
- Flow Check by Reed sensor at 0,5 bar minimum opening pressure
- Wall mounting version via built-in bracket



WATER TREATMENT DIVISION

PSD4 SERIES

PORTASONDA A DEFLUSSO

HOUSING PROBE HOLDER BYPASS CONNECTION

PSD4.B

- Portasonda per 3 sonde di diametro 12 mm
- Temperatura 40°C
- Pressione 2 bar
- Black glass
- Alta acidità Ph 2,7

- Housing probe holder for 3 probes diameter 12 mm
- Temperature 40°C
- Pressure 2 bar
- Black glass
- High acidity PH 2,7

PSD4.BS

- Portasonda per 1 sonda di diametro 35 o 42mm
- Temperatura 40°C
- Pressione 2 bar
- Black glass
- Alta acidità Ph 2,7

- Housing probe holder for 1 probe diameter 35 or 42 mm
- Temperature 40°C
- Pressure 2 bar
- Black glass
- High acidity PH 2,7

PSD4.T

- Portasonda per 3 sonde di diametro 12 mm
- Temperatura 40°C
- Pressione 2 bar

- Housing probe holder for 3 probes diameter 12 mm
- Temperature 40°C
- Pressure 2 bar

PSD4.TS

- Portasonda per 1 sonda di diametro 24 mm
- Temperatura 40°C
- Pressione 2 bar

- Housing probe holder for 1 probe diameter 24 mm
- Temperature 40°C
- Pressure 2 bar



STEP.UP

- Grazie alla Tecnologia Switching presente sull'Alimentatore STEP.UP è possibile installare Strumenti o Sistemi di Dosaggio in tutte quelle applicazioni dove non è possibile avere un'alimentazione tradizionale
- Ingresso 12÷24 Vdc
- Uscita 100 Vdc
- Assorbimento massimo 10 W
- Dimensioni 42x116x28 mm

- Due to changing to STEP.UP circuit technology, it is possible to install Controller Instruments a Dosing Pumps where a traditional power supply is not present. Below is a list of example for possible installation
- 12÷24 Vdc Voltage Input
- 100 Vdc Output
- 10 W Consumption
- 42x116x28 mm Dimensions



SWIMMING POOL DIVISION

ATHENA.PR SERIES

POMPE DOSATRICI ELETTROMAGNETICHE ELECTROMAGNETIC DOSING PUMPS

CARATTERISTICHE GENERALI GENERAL FEATURES



• DIGITALE A PORTATA PROPORZIONALE CON STRUMENTO pH/Rx

- range di misura pH 0÷14 - Rx -999÷+999 mV
- compensazione automatica/manuale della temperatura (pH)
- uscita 4÷20 mA su tutta la scala per registrazione
- Calibrazione automatica/manuale con indicazione efficienza della sonda

• DIGITAL PROPORTIONAL FLOW WITH pH/Rx INSTRUMENTS

- pH 0÷14 - Rx -999÷+999 mV measuring range
- manual/automatic temperature compensation (pH)
- 4÷20 mA output on all the recording scale
- manual/automatic calibration with probe efficiency evaluation

• FUNZIONE DI COMANDO "TIMER RITARDO DOSAGGIO DELLA POMPA"

- Alcune volte, all'accensione della pompa dosatrice, è necessario attendere la stabilità di misura chimica per effettuare un corretto dosaggio. Per facilitare il lavoro dell'installatore è disponibile un Timer nel Menù Impostazioni per ritardare il dosaggio all'accensione della pompa

• SOFTWARE FUNCTION "TO SET DELAY TIME DOSING ABOUT PUMP"

- Sometimes when switching the dosing pump on, we need to wait for the chemical measure stability in order to make a proper dosage. To make the installer work easy, it is available a Timer into Pump Menu in order to delay dosing action when switching the dosing pump on.

MODELLI CARATTERISTICHE TECNICHE MODELS AND TECHNICAL FEATURES

ATHENA 2

PORTATE FLOW RATES	PRESSIONI PRESSURES	CC/IMP. CC/STROKE	CONNESSIONI CONNECTIONS	IMP./MIN STROKES/MIN.	ASSORBIMENTO CONSUPTION
3 l/h	12 bar	0,31	4x6	160	14 Watt
4 l/h	10 bar	0,42	4x6	160	14 Watt
5 l/h	8 bar	0,52	4x6	160	14 Watt
8 l/h	2 bar	0,83	4x6	160	14 Watt

ATHENA 3

PORTATE FLOW RATES	PRESSIONI PRESSURES	CC/IMP. CC/STROKE	CONNESSIONI CONNECTIONS	IMP./MIN STROKES/MIN.	ASSORBIMENTO CONSUPTION
7 l/h	16 bar	0,39	4x6	300	28 Watt
10 l/h	10 bar	0,55	4x6	300	28 Watt
14 l/h	6 bar	0,78	4x6	300	28 Watt
16 l/h	2 bar	0,89	4x6	300	28 Watt

ATHENA 4

PORTATE FLOW RATES	PRESSIONI PRESSURES	CC/IMP. CC/STROKE	CONNESSIONI CONNECTIONS	IMP./MIN STROKES/MIN.	ASSORBIMENTO CONSUPTION
20 l/h	5 bar	1,11	8x12	300	28 Watt
22 l/h	4 bar	1,22	8x12	300	28 Watt
35 l/h	2 bar	1,94	8x12	300	28 Watt
50 l/h	0,1 bar	2,78	8x12	300	28 Watt



ELECTROMAGNETIC PRODUCTS OLIMPIA SERIES

POMPE DOSATRICI ELETTRICHE ELECTROMAGNETIC DOSING PUMPS

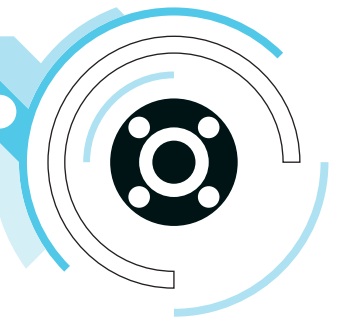

CARATTERISTICHE GENERALI - GENERAL FEATURES



آتور صنعت
ATOORSANAT

- ANALOGICA A PORTATA COSTANTE
- TESTA IN PVDF adatta per prodotti chimici usati nelle applicazioni industriali, nel trattamento acqua e nella potabilizzazione
- CASSA IN POLIPROPILENE IGNIFUGA E ANTI-ACIDO
- REGOLAZIONE MANUALE DELLA PORTATA 0÷100%
- VALVOLA DI ADESCAMENTO MANUALE
- ALIMENTAZIONE ED INGRESSO SONDA DI LIVELLO con Attacco Rapido
- LED CON STATO DI FUNZIONAMENTO
- PROTEZIONE IP65

- ANALOGIC WITH COSTANT FLOW
- PVDF PUMP HEAD suitable for chemical used in the Industrial, Waste Water Treatment and Potable Water applications
- FIREPROOF AND ANTI-ACID POLYPROPYLENE BOX
- FLOW RATE MANUALLY ADJUSTABLE 0÷100%
- MANUAL PRIMING VALVE
- POWER SUPPLY AND LEVEL PROBE INLET with Quick Connection
- WORKING STATE LED
- IP65 PROTECTION DEGREE

MODELLI E CARATTERISTICHE TECNICHE - MODELS AND TECHNICAL FEATURES

OL.BP

PORTATE FLOW RATES	PRESSIONI PRESSURES	CC/IMP. CC/STROKE	CONNESSIONI CONNECTIONS	IMP./MIN STROKES/MIN.	ASSORBIMENTO CONSUPTION	ALIMENTAZIONE POWER SUPPLY
5 l/h	5 bar	0,52	4x6	140	14 Watt	100÷240 VAC 50/60 HZ 24÷48 VAC
2 l/h	7 bar	0,33	4x6	100	14 Watt	100÷240 VAC 50/60 HZ 24÷48 VAC



SWIMMING POOL DIVISION

NIKE.TEMP SERIES

POMPA PERISTALTICA DIGITALE DIGITAL PERISTALTIC PUMP

CARATTERISTICHE GENERALI GENERAL FEATURES

- TRATTAMENTO PISCINE SPA, DOCCE, LAVAPIEDI ED ESSENZE
- DOSAGGIO TEMPORIZZATO E FUNZIONE BATCH (1 min.)
- SPA SWIMMING POOL, SHOWER AND ESSENCES TREATMENT
- TEMPORISED DOSING AND BATCH FUNCTION (1 min.)

CARATTERISTICHE TECNICHE TECHNICAL FEATURES

PORTATE FLOW RATES	PRESSIONI PRESSURES	ALIMENTAZIONE POWER SUPPLY
2 lt/h	1,5 bar	100÷240 Vac



BIO.TEMP SERIES

SISTEMA DI DOSAGGIO TEMPORIZZATO TEMPORISED DOSING SYSTEM

CARATTERISTICHE GENERALI GENERAL FEATURES

- DOSAGGIO FLOCCULANTE ED ESSENZE • DOSAGGIO CON OROLOGIO SETTIMANALE • CONTROLLO LIVELLO SERBATOIO • INTERRUTTORE ON/OFF/ADESCAMENTO • INGRESSO IN TENSIONE 240VAC "Segnale Elettrico dalla Pompa di Ricircolo" • ALLARME REMOTO VIA RELÉ (Contatto Pulito) • SETTAGGIO DEI PARAMETRI VIA MENU • DISPLAY 16x2 (Blue/Bianco)

- FLOCCULENT AND ESSENCES DOSING • DOSING WITH WEEKLY TIMER • TANK LEVEL CONTROL • ON/OFF/SWITCH PRIMING • 240 VAC TENSION INPUT "Electrical Signal from Circulating Pumps" • REMOTE ALARM THROUGH RELAYS (Dry Contact) • SETTING OF THE PARAMETER VIA MENU • 16x2 DISPLAY (Blue/White)

CARATTERISTICHE TECNICHE TECHNICAL FEATURES

PORTATE FLOW RATES	PRESSIONI PRESSURES	ALIMENTAZIONE POWER SUPPLY	ASSORBIMENTO CONSUPTION
2,5÷25 ml/h	1,5 bar	100÷240 Vac	8 W
15,1÷151 ml/h	1,5 bar	100÷240 Vac	8 W
151,2÷1512 ml/h	1,5 bar	100÷240 Vac	8 W
540÷5400 ml/h	1,5 bar	100÷240 Vac	8 W
975÷9750 ml/h	1,5 bar	100÷240 Vac	8 W





SYSTEM PRODUCTS ELITE SERIES

SISTEMI DI DOSAGGIO DOSING SYSTEMS

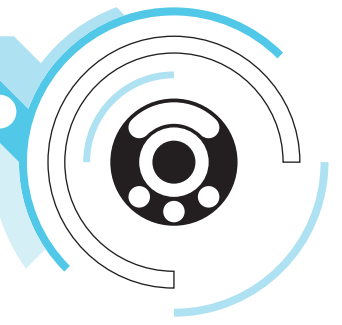

CARATTERISTICHE GENERALI - GENERAL FEATURES



ELITE.pH/.Rx

- SISTEMA DIGITALE PER IL CONTROLLO DI pH/Rx CON POMPA PERISTALTICA
- 12x2 DISPLAY (Blue/Bianco)
- 240 VAC TENSION INPUT
- DIGITAL SYSTEM FOR pH/Rx CONTROL WITH PERISTALTIC PUMP
- 16x2 DISPLAY (Blue/White)
- 240 VAC TENSION INPUT

CARATTERISTICHE TECNICHE - TECHNICAL FEATURES

RANGE	PORTATA FLOW RATE	PRESSIONE PRESSURE	ALIMENTAZIONE POWER SUPPLY
6,2÷8,0 pH	1,5÷5 lt/h	1,5 bar	100÷240 Vac
480÷750 mV 660÷930 mV	1,5÷5 lt/h	1,5 bar	100÷240 Vac

آتور صنعت
ATOORSANAT

CARATTERISTICHE GENERALI - GENERAL FEATURES



ELITE.PR

- SISTEMA DIGITALE PER IL CONTROLLO DI pH/Rx CON 2 POMPE PERISTALTICHE
- 12x2 DISPLAY (Blue/Bianco)
- 240 VAC TENSION INPUT
- DIGITAL SYSTEM FOR pH/Rx CONTROL WITH 2 PERISTALTIC PUMPS
- 16x2 DISPLAY (Blue/white)
- 240 VAC TENSION INPUT

CARATTERISTICHE TECNICHE - TECHNICAL FEATURES

RANGE	PORTATA FLOW RATE	PRESSIONE PRESSURE	ALIMENTAZIONE POWER SUPPLY
0÷14,00 pH	1,5÷5 lt/h	1,5 bar	100÷240 Vac
0÷1000 mV	1,5÷5 lt/h	1,5 bar	100÷240 Vac



SYSTEM PRODUCTS

ELITE.PRC SERIES

SISTEMI DI DOSAGGIO DOSING SYSTEMS

CARATTERISTICHE GENERALI GENERAL FEATURES



ELITE.PRC

- SISTEMA DIGITALE PER IL CONTROLLO DI Cl pH/Rx CON 2 POMPE PERISTALTICHE
- MISURA CL LIBERO CON SONDA AMPEROMETRICA
- 12x2 DISPLAY (Blue/Bianco)
- 240 VAC TENSION INPUT

- DIGITAL SYSTEM FOR Cl pH/Rx CONTROL WITH 2 PERISTALTIC PUMPS
- FREE CHLORINE MEASURE WITH AMPEROMETRIC PROBE
- 16x2 DISPLAY (Blue/white)
- 240 VAC TENSION INPUT

CARATTERISTICHE TECNICHE TECHNICAL FEATURES

RANGE	PORTATA FLOW RATE	PRESSIONE PRESSURE	ALIMENTAZIONE POWER SUPPLY
6,2÷8,0 pH	1,5÷5 lt/h	1,5 bar	100÷240 Vac
480÷750 mV 660÷930 mV			
0-5 PPM Cl	1,5÷5 lt/h	1,5 bar	

CARATTERISTICHE GENERALI GENERAL FEATURES



ELITE.SP PRC

- SISTEMA DIGITALE PER IL CONTROLLO DI Cl pH/Rx CON 2 POMPE ELETTROMAGNETICHE
- MISURA CL LIBERO CON SONDA AMPEROMETRICA
- 12x2 DISPLAY (Blue/Bianco)
- 240 VAC TENSION INPUT

- DIGITAL SYSTEM FOR Cl pH/Rx CONTROL WITH 2 ELECTROMAGNETIC PUMPS
- FREE CHLORINE MEASURE WITH AMPEROMETRIC PROBE
- 16x2 DISPLAY (Blue/white)
- 240 VAC TENSION INPUT

CARATTERISTICHE TECNICHE TECHNICAL FEATURES

RANGE	PORTATA FLOW RATE	PRESSIONE PRESSURE	ALIMENTAZIONE POWER SUPPLY
0÷14,00 pH	5 lt/h	5 bar	100÷240 Vac 50/60Hz 12/18W
0÷1000 mV			
0-5 PPM Cl	5 lt/h	5 bar	



SWIMMING POOL DIVISION
ELITE.PLUS SERIES
SISTEMI DI DOSAGGIO DOSING SYSTEMS



CARATTERISTICHE GENERALI - GENERAL FEATURES



ELITE pH⁻ pH⁺ / pH Flocculant

- SISTEMA DI DOSAGGIO PER L'ANALISI E DOSAGGIO DI pH⁺ e pH⁻
- SISTEMA DI DOSAGGIO PER L'ANALISI E DOSAGGIO DI pH E DOSAGGIO TEMPORIZZATO PER FLOCCULANTE
- DOSING SYSTEM TO ANALYSE AND ADJUST pH⁺ and pH⁻
- DOSIGN SYSTEM TO ANALYSE AND ADJUST pH AND TIME DOSING METHOD FOR FLOCCULANT

CARATTERISTICHE TECNICHE - TECHNICAL FEATURES

RANGE	PORTATA FLOW RATE	PRESSIONE PRESSURE	ALIMENTAZIONE POWER SUPPLY
0÷14,00 pH	1,5÷5 lt/h	1,5 bar	100÷240 Vac
0÷1000 mV	1,5÷5 lt/h	1,5 bar	100÷240 Vac

CARATTERISTICHE GENERALI - GENERAL FEATURES



ELITE.PHP pH HYDROGEN PEROXIDE

- SISTEMA DI DOSAGGIO PER L'ANALISI E DOSAGGIO DI pH
- DOSAGGIO TEMPORIZZATO DI PEROSSIDO DI IDROGENO (H₂O₂) CON COMPENSAZIONE DELLA TEMPERATURA
- DOSING SYSTEM TO ANALYSE AND ADJUST pH
- HYDROGEN PEROXIDE (H₂O₂) DOSAGE IN TIME MODE WITH TEMPERATURE COMPENSATION

CARATTERISTICHE TECNICHE - TECHNICAL FEATURES

RANGE	PORTATA FLOW RATE	PRESSIONE PRESSURE	ALIMENTAZIONE POWER SUPPLY
0÷14,00 pH	1,5÷5 lt/h	1,5 bar	100÷240 Vac
0÷1000 mV	1,5÷5 lt/h	1,5 bar	100÷240 Vac



CARATTERISTICHE GENERALI - GENERAL FEATURES



ELITE pH⁻ pH⁺ RX / pH⁺ pH⁻ Flocculant

- SISTEMA DI DOSAGGIO PER L'ANALISI E DOSAGGIO DI pH⁺, pH⁻ e REDOX
- SISTEMA DI DOSAGGIO PER L'ANALISI E DOSAGGIO DI pH⁺, pH⁻ e DOSAGGIO TEMPORIZZATO PER FLOCCULANTE

- DOSING SYSTEM TO ANALYSE AND ADJUST pH⁺, pH⁻ AND REDOX
- DOSIGN SYSTEM TO ANALYSE AND ADJUST pH⁺, pH⁻ AND TIMED DOSING FOR FLOCCULANT

CARATTERISTICHE TECNICHE - TECHNICAL FEATURES

RANGE	PORTATA FLOW RATE	PRESSIONE PRESSURE	ALIMENTAZIONE POWER SUPPLY
0÷14,00 pH	1,5÷5 lt/h	1,5 bar	100÷240 Vac
0÷1000 mV	1,5÷5 lt/h	1,5 bar	100÷240 Vac

CARATTERISTICHE GENERALI - GENERAL FEATURES



ELITE.PHP ACTIVATION POOL

- SISTEMA DI DOSAGGIO PER L'ANALISI E IL CONTROLLO DI pH e REDOX
- TIMER SETTIMANALE DI ATTIVAZIONE SCAMBIATORE DI CALORE E CONTATTO DI FLUSSO POMPA DI RECIRCOLO

- DOSING SYSTEM TO ANALYSE AND CONTROL pH AND REDOX
- WEEKLY TIMER TO ACTIVATE HEAT EXANGER AND CIRCULATION PUMP

CARATTERISTICHE TECNICHE - TECHNICAL FEATURES

RANGE	PORTATA FLOW RATE	PRESSIONE PRESSURE	ALIMENTAZIONE POWER SUPPLY
0÷14,00 pH	1,5÷5 lt/h	1,5 bar	100÷240 Vac
0÷1000 mV	1,5÷5 lt/h	1,5 bar	100÷240 Vac



SWIMMING POOL DIVISION ELITE.PLUS SERIES

SISTEMI DI DOSAGGIO DOSING SYSTEMS



CARATTERISTICHE GENERALI - GENERAL FEATURES



ELITE.PRF ACTIVATION POOL

- SISTEMA DI DOSAGGIO PER L'ANALISI E IL CONTROLLO DI pH, REDOX E DOSAGGIO TEMPORIZZATO PER FLOCCULANTE
- TIMER SETTIMANALE DI ATTIVAZIONE SCAMBIATORE DI CALORE E CONTATTO DI FLUSSO POMPA DI RECIRCOLO
- DOSING SYSTEM TO ANALYSE AND CONTROL pH, REDOX AND TIMED DOSING METHOD FOR FLOCCULANT
- WEEKLY TIMER TO ACTIVATE HEAT EXANGER AND CIRCULATION PUMP

CARATTERISTICHE TECNICHE - TECHNICAL FEATURES

RANGE	PORTATA FLOW RATE	PRESSIONE PRESSURE	ALIMENTAZIONE POWER SUPPLY
0÷14,00 pH	1,5÷5 lt/h	1,5 bar	100÷240 Vac
0÷1000 mV	1,5÷5 lt/h	1,5 bar	100÷240 Vac

CARATTERISTICHE GENERALI - GENERAL FEATURES



ELITE.SP PR

- SISTEMA DI DOSAGGIO PROPORZIONALE COMPOSTO DA 1 STRUMENTO CON DOPPIA MISURA E 2 POMPE DOSATRICI ELETTROMAGNETICHE
- ALLARME REMOTO TRAMITE UN RELÉ SPECIFICO
- CALIBRAZIONE AUTOMATICA DELLE SONDE
- DISPONIBILE VERSIONE A SINGOLA POMPA
- PROPORTIONAL DOSING SYSTEM COMPOSED OF A CONTROL INSTRUMENT WITH DOUBLE MEASUREMENT AND 2 SOLENOID PUMPS
- RELAY OUTPUT FOR REMOTE ALARM
- AUTOMATIC CALIBRATION PROBES
- SINGLE PUMP VERSION AVAILABLE

CARATTERISTICHE TECNICHE - TECHNICAL FEATURES

RANGE	PORTATA FLOW RATE	PRESSIONE PRESSURE	VISUALIZZAZIONE VISUALIZATION	ACCURATEZZA ACCURACY	ALIMENTAZIONE POWER SUPPLY
0÷14,00 pH	5 lt/h	5 bar	±0,1	±0,02	100÷240 Vac 50/60Hz 12/18W
0÷1000 mV	5 lt/h	5 bar	±10 mV	±3 mV	100÷240 Vac 50/60Hz 12/18W



SYSTEMPRODUCTS

HELIOS SERIES

SISTEMI AUTOMATICI DI CONTROLLO AUTOMATIC CONTROL SYSTEMS

CARATTERISTICHE GENERALI GENERAL FEATURES



HELIOS.01

- PANNELLO DIGITALE COMPOSTO DA:
 - POMPE ELETTROMAGNETICHE DIGITALI CON STRUMENTO pH/Rx INCORPORATO (ATHENA.PR.SERIES)
 - SONDA pH, SONDA Rx, E SONDA DI BASSO LIVELLO
 - PORTASONDA A DEFLUSSO CON SENSORE DI FLUSSO IN PLEXIGLASS
 - FILTRO
 - PANNELLO IN PVC 40x60 cm
 - SOLUZIONI TAMPONE (pH-Redox)
 - IL TUTTO MONTATO E CABLATO
-
- DIGITAL PANEL SUPPLIED WITH:
 - DIGITAL ELECTROMAGNETIC PUMPS WITH BUILT-IN pH/REDOX (ATHENA.PR.SERIES)
 - pH PROBE, REDOX PROBE AND LOW LEVEL PROBE
 - BATH TYPE PROBE HOLDER WITH PLEXIGLASS FLOW SENSOR
 - FILTER
 - PVC PANEL 40x60 cm
 - BUFFER SOLUTION (pH-REDOX)
 - ALL ASSEMBLED AND CABLED READY TO BE INSTALLED

آتور صنعت
ATOORSANAT



CARATTERISTICHE GENERALI - GENERAL FEATURES



HELIOS.05

- **PANNELLO DIGITALE COMPOSTO DA:**
 - POMPE ELETTROMAGNETICHE ANALOGICHE MULTIFUNZIONE (ATHENA.AMSERIES) • CENTRALINA MULTIPARAMETRICA (NEXUS.7000SERIES) • SONDA pH, SONDA DI CLORO CON SENSORE DI FLUSSO REGOLABILE, RUBINETTO PRELIEVO CAMPIONE, FILTRO DEGASAGGIO • SONDE DI BASSO LIVELLO • PANNELLO IN PVC 80x60 cm • SOLUZIONI TAMPONE (pH-Redox) • IL TUTTO MONTATO E CABLATO
- **DISPONIBILE LA VERSIONE CLORO POTENZIOSTATICO**
- **DIGITAL PANEL SUPPLIED WITH:**
 - ANALOGIC MULTIFUNCTION DOSING PUMPS (ATHENA.AMSERIES) • MULTIPARAMETER SWITCH BOARD (NEXUS.7000SERIES) • pH PROBE, CHLORINE PROBE WITH REGULABLE FLOW SENSOR, SAMPLE WATER FAUCET, DEGASSING FILTER • PVC PANEL 40x60 cm • BUFFER SOLUTION (pH-REDOX) • ALL ASSEMBLED AND CABLED READY TO BE INSTALLED
- **AVAILABLE POTENTIOSTATIC CHLORINE VERSION**

آتور صنعت

Modelli disponibili available models

HELIOS.05 CL con with AT.AM 02 100÷240 Vac
HELIOS.05 CL solo lettura without pumps 100÷240 Vac
HELIOS.05 PC con with AT.AM 02 100÷240 Vac
HELIOS.05 PC con with AT.AM 04 100÷240 Vac
HELIOS.05 PH-CL solo lettura without pumps 100÷240 Vac
HELIOS.05 PH-Potentiostatic con with AT.AM 02 100÷240 Vac
HELIOS.05 PH-Redox con with AT.AM 02 100÷240 Vac
HELIOS.05 PH-Redox-Cl solo lettura without pumps 100÷240 Vac
HELIOS.05 Cl Potentiostatic solo lettura without pumps
HELIOS.05 PH-Cl Potentiostatic solo lettura without pumps
HELIOS.05 PH-Cl Potentiostatic-RX solo lettura without pumps
HELIOS.05 PH-Cl FREE-CL TOT - T° solo lettura without pumps



SOFTWARE

- **SOFTWARE DI TRASMISSIONE DATI** tramite Porta Seriale RS485 con protocollo Modbus RTU realizza una Gestione Remota su tutti i modelli HELIOS.05
- È possibile registrare i Dati di Misura in tempo reale di **CLORO, pH, REDOX e TEMP**
- **LA RETE DI TRASMISSIONE** prevede la Gestione Simultanea di 99 Pannelli HELIOS.05. Con un unico cavo a 3 fili e tramite un adattatore Hardware Seriale RS485/USB2.0 si ha la possibilità di collegare il tutto al PC e gestire tutti i parametri del Sistema con un unico Software
- **IL SOFTWARE DI GESTIONE** permette di gestire un modem GPRS esterno (Funzione Opzionale) collegato al PC per inviare via SMS gli allarmi che dovessero verificarsi per richiedere un rapido intervento
- **SOFTWARE FOR REMOTE CONTROL COMMUNICATIONE** thanks with Serial Port and MODBUS RTU Protocol to make a Network Communication with all HELIOS.05 SERIES
- It is possible to have Data Logger in real time for **CHLORINE, pH, REDOX and TEMP** measures
- **NETWORK COMMUNICATION** assures to Control 99 HELIOS.05 Panels contemporarily. This can be done through 3 wires into 1 cable linked to an Adapter Bridge RS485/USB Port. It is possible to connect every unit to PC and operate by 1 Software to set all Parameters System
- **THE RCC SOFTWARE ADMINISTRATOR** sends an SMS alarm by a GPRS external modem (Optional Unit), it is connected to PC

CARATTERISTICHE TECNICHE TECHNICAL FEATURES



- Il Software consente di gestire in simultanea 99 pannelli tramite una pratica console.
- Aggiornamento Misure impostabile dall'Utente (tempo minimo 30 sec)
- The Software Administrator displays by easy Layout Windows the values measured simultaneously in 99 Control Panels
- The End-User can change the Timing Measures (the minimum value is 30 sec)

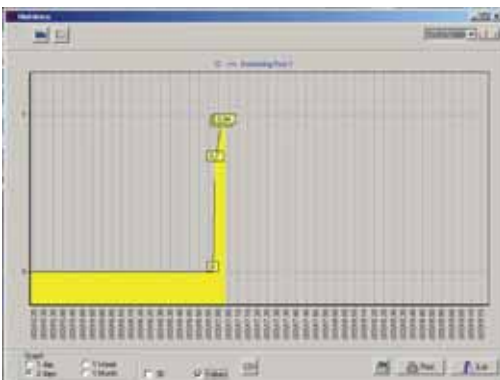

- Selezionando la voce "Graphic" sulla misura è possibile visualizzare i grafici registrati giorno per giorno ed analizzare l'andamento registrato
- By choosing the Measures it is possible to have a Graphic Line to record data day by day and analyze the status of measures



SWIMMING POOL DIVISION STERIL SERIES

STERILIZZATORE A SALE SALT STERILIZER



CARATTERISTICHE GENERALI GENERAL FEATURES



- **BASATO SUL PRINCIPIO DELL'ELETTROLISI**
- **IL SALE È TRASFORMATO IN IPOCLORITO DI SODIO**
- **SISTEMA CON DISPOSITIVO DI SICUREZZA**
- **BLOCCO AUTOMATICO DEL SISTEMA IN CASO DI ALLARME**
- **ELETTRODI AUTOPULENTI AD ALTA TECNOLOGIA IN TITANIO**
- **MONITORAGGIO E FACILITÀ DI LETTURA** con sistema di parametraggio su un grande schermo LCD retro illuminato
- **BASED THE PRINCIPLE OF THE ELECTROLYSIS**
- **SALT IS TURNED INTO SODIUM HYPOCHLORITE**
- **AUTOMATIC SAFETY SYSTEM**
- **AUTOMATIC STOP SYSTEM**
- **HIGH TECHNOLOGY TITANIUM SELF-CLEANING ELECTRODES**
- **EASY TO READ AND CONTROL** thank to the big backlit LCD display

CARATTERISTICHE TECNICHE TECHNICAL FEATURES

MODELLI MODELS	12-18-35 gr/h
CONTROLLO CONTROL	a microprocessore microprocessor
ALIMENTAZIONE POWER SUPPLY	230Vac/5 -60 Hz / H05RR-F3G (3x1 mm ²)
SISTEMA AUTOPULENTE SELF-CLEANING SYSTEM	cambio Polarità Automatica Programmabile Programmable Automatic Change of Polarity

CARATTERISTICHE TECNICHE TECHNICAL FEATURES



SALINITÀ RACCOMANDATA SALINNESS RECOMMENDED	4,5g NaCl/lit
RANGE SALINITÀ SALINNESS RANGE	4÷6 g/lit
ELETTRODO ELECTRODE	titanio con Ossidi Speciali Titanium with Special oxides
PRESSIONE MAX MAX PRESSURE	1,5 Kg/cm ²
TEMPERATURA MAX MAX TEMPERATURE	40°C / 104°F
PORTAELETTRODO ELECTRODE HOLDER	polimero famiglia del Metacrilato Metacrilate Polymer
ALLACCIAMENTO A TUBATURE PIPES CONNECTION	incollato con adesivo per PVC / Ø63 sticked with Glue for PVC / Ø63
PRODUZIONE DI NaClO NaClO PRODUCTION (25°C=4,5 g/l NaClO)	6 m ³ MAMMET35 / 3 m ³ MAMMET18
N° PLACCHE PER ELETTRODO N° OF PLATES PER ELECTRODE	10+ sensore di flusso flow sensor MAMMET35 6+ sensore di flusso flow sensor MAMMET18
SONDA DI TEMPERATURA TEMPERATURE PROBE	semiconduttore semiconductor
PERDITA DI CARICO FLOW LOSS (20m ³ /h)	0,15 kg/cm ²



CARATTERISTICHE GENERALI - GENERAL FEATURES



STERIL.PANEL 01

- PANNELLO COMPLETO DI STERILIZZATORE SALINO CON ATTIVAZIONE ATTRAVERSO LA LETTURA DEL REDOX
- MISURA pH E DOSAGGIO CON POMPA PERISTALTICA
- PORTASONDA A DEFLUSSO PER SONDE pH/Rx/Temp
- DISPONIBILE CON STERILIZZATORE SALINO 12-18-35 gr/h

- COMPLETE PANEL WITH SALT CHLORINATOR WITH ACTIVATION SYSTEM BY REDOX MEASUREMENT
- pH MEASUREMENT AND DOSAGE WITH PERISTALTIC PUMP
- BATH TYPE PROBE HOLDER FOR pH/RX/Temp PROBES
- AVAILABLE WITH 12-18-35 gr/h SALT CHLORINATOR



STERIL.PANEL 02

- PANNELLO COMPLETO DI STERILIZZATORE SALINO CON ATTIVAZIONE ATTRAVERSO LA LETTURA DEL REDOX
- MISURA pH E DOSAGGIO CON POMPA ELETTROMAGNETICA
- PORTASONDA A DEFLUSSO PER SONDE pH/Rx/Temp
- DISPONIBILE CON STERILIZZATORE SALINO 12-18-35 gr/h

- COMPLETE PANEL WITH SALT CHLORINATOR WITH ACTIVATION SYSTEM BY REDOX MEASUREMENT
- pH MEASUREMENT AND DOSAGE WITH ELECTROMAGNETIC PUMP
- BATH TYPE PROBE HOLDER FOR pH/RX/Temp PROBES
- AVAILABLE WITH 12-18-35 gr/h SALT CHLORINATOR



STERIL.PANEL 03

- PANNELLO COMPLETO DI STERILIZZATORE SALINO CON ATTIVAZIONE ATTRAVERSO LA LETTURA DEL REDOX TRAMITE STRUMENTO DIGITALE
- MISURA pH E DOSAGGIO CON POMPA ELETTROMAGNETICA
- PORTASONDA A DEFLUSSO PER SONDE pH/Rx/Temp
- DISPONIBILE CON STERILIZZATORE SALINO 12-18-35 gr/h

- COMPLETE PANEL WITH SALT CHLORINATOR WITH ACTIVATION SYSTEM BY REDOX READING THROUGH DIGITAL INSTRUMENTS
- pH MEASUREMENT AND DOSAGE WITH ELECTROMAGNETIC PUMP
- BATH TYPE PROBE HOLDER FOR pH/RX/Temp PROBES
- AVAILABLE WITH 12-18-35 gr/h SALT CHLORINATOR



Chlorine.Meter SERIES

COLORIMETRO INDUSTRIALE E MULTIFUNZIONE
MULTIFUNCTION INDUSTRIAL CHLORINE METER



CARATTERISTICHE GENERALI GENERAL FEATURES

DI.FO

- **RELÉ DI USCITA CONFIGURABILI COME SET-POINT, ALLARMI DI MASSIMA, ALLARMI DI MINIMA, PWM** Regolazione Proporzionale nel Tempo, **PFM** Regolazione Proporzionale ad Impulsi, **AUTOPULIZIA**
- **POSSIBILITÀ DI AVERE IN USCITA BASSA TENSIONE 24V** Pilotaggio di piccole Dosatrici o Elettrovalvole senza aggiunta di altri Trasformatori e con Tensione di Sicurezza
- **SEPARAZIONE GALVANICA TRA INGRESSI / MICROPROCESSORE E USCITE IN CORRENTE**
- **INGRESSO OFF** per spegnere i Relé di Regolazione e fermare il ciclo del Colorimetro, Eventuale **INGRESSO FLW** per Controllo Flusso Acqua all'Apparecchiatura, **USCITA "OK"** per segnalare a distanza il corretto Funzionamento
- Visualizzazioni: **ALLARMI ED ERRORI (Diagnostica), DATARIO/ORARIO** presente anche in assenza di alimentazione e con possibilità di **ATTIVARE / DISATTIVARE IL FUNZIONAMENTO DEL COLORIMETRO** in fasce orarie prestabilite
- **SALVATAGGIO DEI DATI DEL PROGRAMMA / TARATURA SU MEMORIA NON VOLATILE**
- **USCITA SERIALE RS232C PER COLLOQUIO / PROGRAMMAZIONE CON PC, PLC** disponibile su Connettore CANNON 9 Pins femmina o in Morsettiera su richiesta
- **OUTPUT RELAY AS SET POINTS, MAXIMUM AND MINIMUM ALARMS, PWM** Proportional Regulating of the Time, **PFM** Proportional Pulse Regulation, **SELF-CLEANING**
- **IT IS POSSIBLE TO HAVE LOW VOLTAGE 24V** enabling the Monitoring of Smaller Doses with Solenoid Valves and without the addition of other Transformer, with a Security Power Supply
- **GALVANIC SEPARATION BETWEEN MICROPROCESSOR / INLETS AND CURRENT OUTLETS**
- **OFF INLET** to switch off the Regulation Relay and to Stop the Colorimeter Cycle, Possible **FLW INPUT** to control the water flow in the instrument, **"OK" OUTPUT** Remotely Controls the Correct Instrumentation Function
- Visualization: **ALARMS / ERRORS (Diagnostic), DATE / HOUR** (always present, also without Power Supply), with the possibility to **START/STOP THE COLORIMETER FUNCTION** pre-set hours (i.e. nighttime)
- **PROGRAMMING & CALIBRATION SAVED IN MEMORY**
- **RS232C SERIAL OUTPUT FOR PC, PLC** Connector Available on CANNON 9 Connection or Terminal Block



CARATTERISTICHE TECNICHE TECHNICAL FEATURES

RANGE	CL 0÷6 ppm CL/pH 0÷6 ppm / 0÷14 pH CL/pH/Rx/T° 0÷6 ppm / 0÷14 pH / 0÷2000 mV / / 0÷100 °C
ALIMENTAZIONE POWER SUPPLY	220/230 VAC 50-60 Hz ±10%



SWIMMING POOL DIVISION

PoolTester SERIES

FOTOMETRO PORTATILE PER USO DOMESTICO
PHOTOMETER DESIGNED FOR RESIDENTIAL USE

CARATTERISTICHE GENERALI GENERAL FEATURES

APPARECCHIATURA DI ANALISI PER PISCINE PRIVATE E VASCHE
IDROMASSAGGIO PER UTENTI ESIGENTI

TEST EQUIPMENT FOR THE RESPONSIBLE PRIVATE POOL AND
WHIRLPOOL OPERATOR



CARATTERISTICHE TECNICHE TECHNICAL FEATURES

DETERMINAZIONE DETERMINATION	RANGE RANGE	RISOLUZIONE RESOLUTION	ACCURATEZZA ACCURACY
CLORO LIBERO FREE CHLORINE	0.05 - 6 mg/l Cl ₂	0.01 mg/l	0 - 1 mg/l ± 0.1 mg/l ; 1 - 2 mg/l ± 0.2 mg/l 2 - 3 mg/l ± 0.4 mg/l ; 3 - 6 mg/l ± 0.5 mg/l
CLORO TOTALE TOTAL CHLORINE	0.05 - 6 mg/l Cl ₂	0.01 mg/l	0 - 1 mg/l ± 0.1 mg/l ; 1 - 2 mg/l ± 0.2 mg/l 2 - 3 mg/l ± 0.4 mg/l ; 3 - 6 mg/l ± 0.5 mg/l
VALORE pH ph VALUE	6.5 - 8.4 pH	0.1 pH	± 0.2 pH
STABILIZZANTE STABILIZER (cyanuric acid)	5 - 8.4 pH	1.0 mg/l	5 - 50 mg/l ± 10 mg/l ; 50 - 160 mg/l ± 20 mg/l
ALCALINITA' ALKALINITY	10 - 300 mg/l CaCO ₃	1.0 mg/l	± 50 mg/l

PO.VF SERIES

FOTOMETRO ELETTRONICO COMPATTO COMPACT ELECTRONIC PHOTOMETER

CARATTERISTICHE TECNICHE TECHNICAL FEATURES

RANGE	pH/CL/Cyn 6,8÷8,4 / 0,05÷6CL ₂ / 2÷160Cn ⁻
	CL 0,1÷5,00 mg/l
	Cyn 0÷200 m/l
ACCURATEZZA ACCURACY	0,01 ppm
POTENZA POWER	9V (600 h)
CALIBRAZIONE CALIBRATION	automatica automatic
TEMPERATURA TEMPERATURE	0÷40 °C





CARATTERISTICHE GENERALI GENERAL FEATURES



- **INGRESSO IN TENSIONE (15÷30 VDC)** per congelare la misura **SISTEMA DI CONTROLLO REMOTO (HOLD)**
- **SCALE DI MISURA SELEZIONABILI** tramite il menu di programmazione è possibile selezionare la scala di misura disponibile, per garantire una versatilità operativa con un unico strumento
- **LO STRUMENTO RICONOSCE LA SOLUZIONE TAMPONE** (pH/Redox) e completa la calibrazione sospendendo il dosaggio (HOLD) ed indicando lo stato di efficienza dell'elettrodo in %
- **MENÙ MULTILINGUA, PROTEZIONE MENÙ, IMPOSTAZIONI TRAMITE PASSWORD, CONTROLLO QUALITÀ DELLA SONDA DI MISURA**

- **VOLTAGE INPUT (15÷30 VDC)** for suspending the measurement via **REMOTE CONTROL SYSTEM (HOLD)**
- **SELECTABLE MEASUREMENT SCALES** using the programming menu, it is possible to select the available measurement scale to ensure operating versatility with a single instrument
- **INSTRUMENT RECOGNISES THE BUFFER SOLUTION** (pH and Redox) and completes the calibration suspending the dosage (HOLD) and showing the electrode's efficiency in %.
- **MULTILINGUAL MENÙ, PASSWORD PROTECTION FOR SETTING MENÙ, QUALITY INDICATION OF MEASURING PROBES**

آتور صنعت
ATOORSANAT

DISPLAY



- **DISPLAY DIGITALE A LED BLU AD ALTA EFFICIENZA**, a 2 linee di 16 caratteri, permette di visualizzare contemporaneamente 2 parametri: chimica e temperatura
- **DIGITAL DISPLAY WITH HIGH EFFICIENCY BLUE LEDS** with 2 lines of 16 digits per line, allows the contemporaneous visualization of 2 parameters: chemical measure and temperature



CARATTERISTICHE TECNICHE / TECHNICAL FEATURES

NX2000SERIES RANGE	pH - 0÷14,00 (accuratezza accuracy 1%)	
	Rx - ±1000 mV (accuratezza accuracy 1%)	
	CD - 10÷20.000 (accuratezza accuracy 1%)	bassa conducibilità low conductivity 0÷200 µS alta conducibilità high conductivity 0÷50.000 µS
	sonda probe K10 - 10÷2,000 (accuratezza accuracy 1%)	
	sonda probe K5 - 20÷4,000 (accuratezza accuracy 1%)	
	sonda probe K1 - 100÷20.000 (accuratezza accuracy 1%)	
	CL Potentiostatic - 0÷2 / 0÷5 / 0÷10 / 0÷20 / 0÷200 ppm	
NX2500SERIES RANGE	PR - 0÷14,00 / ±1500 mV	
	pH/CD - 0÷14,00 / 0÷20 mS	
TEMPERATURA TEMPERATURE USCITA IN CORRENTE CURRENT OUTPUT ALIMENTAZIONE POWER SUPPLY SET POINT	pH/CL - 0÷14,00 / 0÷200 ppm	
	pH/FLOW - 0÷14,00 / 0÷9.999.999 lt/h	
	CD/FLOW - 0÷20 mS / 0÷9.999.999 lt/h	
	0÷100 °C con with PT100 (accuratezza accuracy 1%)	
	0/4÷20 20÷4/0 mA (±2%) isolata galvanicamente galvanic separation	
ALIMENTAZIONE POWER SUPPLY	100÷240 VAC 50/60 Hz	
SET POINT	2 indipendenti attraverso relé di contatto pulito 10A 250V (carico resistivo) 2 independent throught 10A 250V dry contact relay (resistance load)	

MODELLI / MODELS

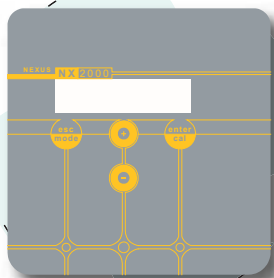

NX.2000 S

- VERSIONE STAGNO
144x144x90 mm
- WATERPROOF VERSION
144x144x90 mm



NX.2000 P

- VERSIONE PANNELLO
96x96x92 mm
- PANEL VERSION
96x96x92 mm



NX.2000 DIN

- VERSIONE BARRA DIN RAIL
6 moduli
- WATERPROOF VERSION
6 modules



NX.2000 Q

- VERSIONE PANNELLO
48x96x100 mm
- PANEL VERSION
48x96x100 mm

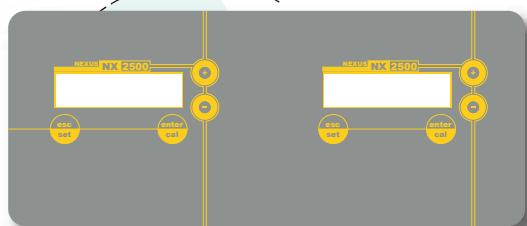

NX.2500 M

- MULTIPARAMETRICO, VERSIONE STAGNO
300x290x143 mm (IP66)
- MULTIPARAMETER, WATERPROOF VERSION
300x290x143 mm (IP66)



CARATTERISTICHE GENERALI GENERAL FEATURES



- REGOLAZIONE DELLA VELOCITÀ DI DOSAGGIO VIA SOFTWARE
- CONTROLLO DEL LIVELLO SERBATOIO
- INTERRUTTORE "ON/OFF/ADESCAMENTO"
- DISPLAY 16x2 (BLU/BIANCO)
- INGRESSO IN TENSIONE 240 Vac "segnale elettrico dalla pompa di ricircolo"
- ALLARME REMOTO VIA RELÉ (Contatto Pulito)
- SETTAGGIO DEI PARAMETRI VIA MENÙ

- DOSING SPEED REGULATION VIA SOFTWARE
- TANK LEVEL CONTROL
- ON/OFF/SWITCH-PRIMING
- 16x2 DISPLAY (BLUE/WHITE)
- TENSION INPUT 240 Vac "electrical signal from circulating pumps"
- REMOTE ALARM THROUGH RELAYS (Dry Contact)
- SETTING OF THE PARAMETERS VIA MENÙ

CARATTERISTICHE TECNICHE TECHNICAL FEATURES

PORTATE FLOW RATES	PRESSIONI PRESSURES	ALIMENTAZIONE POWER SUPPLY
2,5÷25 ml/h	1,5 bar	100÷240 Vac
15,1÷151 ml/h	1,5 bar	100÷240 Vac
180÷1800 ml/h	1,5 bar	100÷240 Vac
396÷3960 ml/h	1,5 bar	100÷240 Vac
900÷9000 ml/h	1,5 bar	100÷240 Vac

MODELLI MODELS

BIO.PROP

● SISTEMA DI DOSAGGIO COSTANTE E PROPORZIONALE

- Applicazioni Trattamento Acque, Acqua Ossigenata per Piscine • Ingresso Segnale in Corrente (0÷20 mA) per Dosaggio Proporzionale • Ingresso in Frequenza (Contatore Lancia-Impulsi) per Dosaggio Proporzionale • Funzione Batch

● COSTANT AND PROPORTIONAL DOSING SYSTEM

- Water Treatment Applications, Peroxide for Swimming Pools • Input mA Signal Current (0÷20 mA) to Control Flow Rate Pump in Proportional Mode • Input Voltage Free (Pulse Signal) to Control Flow Rate Pump in Proportional Mode • Batch Function

BIO.TEMP

● SISTEMA DI DOSAGGIO TEMPORIZZATO

- Dosaggio Flocculante ed Essenze • Dosaggio con Orologio settimanale • Relé Funzione Attivazione "AFTER/BEFORE"

● TEMPORISED DOSING SYSTEM

- Flocculent and Essences Dosing • Dosing with Weekly Timer • Activation Relays "AFTER/BEFORE"



SISTEMI PER TORRI DI RAFFREDDAMENTO
COOLING TOWERS
ELITESERIES
SISTEMI DI DOSAGGIO DOSING SYSTEMS

CARATTERISTICHE GENERALI GENERAL FEATURES



ELITE.SP PR

- SISTEMA DI DOSAGGIO PROPORZIONALE COMPOSTO DA 1 STRUMENTO CON DOPPIA MISURA E 2 POMPE DOSATRICI ELETTROMAGNETICHE
 - ALLARME REMOTO TRAMITE UN RELÉ SPECIFICO
 - CALIBRAZIONE AUTOMATICA DELLE SONDE
 - DISPONIBILE VERSIONE A SINGOLA POMPA
- PROPORTIONAL DOSING SYSTEM COMPOSED OF A CONTROL INSTRUMENT WITH DOUBLE MEASUREMENT AND 2 SOLENOID DOSING
 - RELAY OUTPUT FOR REMOTE ALARM
 - AUTOMATIC CALIBRATION PROBES
 - SINGLE PUMP VERSION AVAILABLE

CARATTERISTICHE TECNICHE TECHNICAL FEATURES

RANGE	PORTATA FLOW RATE	PRESSIONE PRESSURE	VISUALIZZAZIONE VISUALIZATION	ACCURATEZZA ACCURACY	ALIMENTAZIONE POWER SUPPLY
0÷14,00 pH	5 lt/h	5 bar	±0,1	±0,02	100÷240 Vac 50/60Hz 12/18W
0÷1000 mV	5 lt/h	5 bar	±10 mV	±3 mV	100÷240 Vac 50/60Hz 12/18W



SISTEMI PER TORRI DI RAFFREDDAMENTO
COOLING TOWERS
ATHENASERIES

POMPE DOSATRICI ELETTROMAGNETICHE ELECTROMAGNETIC DOSING PUMPS



CARATTERISTICHE GENERALI GENERAL FEATURES



- **TESTA IN PVDF** adatta per prodotti chimici usati nelle applicazioni industriali, nel trattamento acqua e nella potabilizzazione
- **SFERE IN CERAMICA** affidabilità del dosaggio e compatibilità chimica
- **DIAFRAMMA in PTFE** resistenza e compatibilità con tutti i prodotti chimici
- **DOSAGGIO COSTANTE** Alimentazione multi-tensione stabilizzata 100÷240 Vac 50/60 Hz con basso assorbimento
- **CONNESSIONE RAPIDA**
- **VALVOLA DI SPURGO MANUALE**
- **PROTEZIONE IP65**

- **PVDF PUMP HEAD** suitable for chemical used in the Industrial, Waste Water Treatment and Potable Water applications
- **CERAMIC BALL** full chemical compatibility
- **PTFE DIAPHRAGM** unique life expectancy and compatibility with most chemicals
- **STEADY DOSING** Stabilized Multi Power Supply 100÷240 Vac 50/60 Hz with reduced consumption
- **QUICK CONNECTIONS**
- **MANUAL PRIMING VALVE**
- **IP65 PROTECTION**

ANALOGIC VERSION



- **PORTATA REGOLABILE** con Manopola sul Pannello Frontale
- **POWER-ON e LED ALLARME DI LIVELLO**

- **ADJUSTABLE FLOW RATE** a knob on the Front Panel
- **POWER-ON and LEVEL ALARMS LED**

DIGITAL VERSION

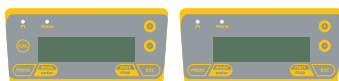

- **DISPLAY LCD RETROILLUMINATO** a 2 Linee di 16 Caratteri
- **PROGRAMMAZIONE E FUNZIONAMENTO** in 5 Lingue Selezionabili
- Possibilità di impostare **PASSWORD DI SICUREZZA**
- Predisposizione per **SENSORE DI FLUSSO**
- **VISUALIZZAZIONE STATISTICHE DI FUNZIONAMENTO**
- **RELÉ DI RIPETIZIONE ALLARME**

- **LCD BACK-LIT DISPLAY** with 2 - 16 Digit Rows
- **PROGRAMMING AND WORKING** in 5 Selectable Languages
- **SECURE PASSWORD AVAILABLE**
- **FLOW SENSOR CONFIGURED**
- **FLASHING OF FUNCTIONING STATISTICS**
- **ALARM REPETITION RELAY**



POSSIBILITÀ DI PERSONALIZZAZIONE SU RICHIESTA
POSSIBILITY CUSTOMIZATION UPON REQUEST



MODELLI E CARATTERISTICHE TECNICHE - MODELS AND TECHNICAL FEATURES

AT.AM

● ANALOGICA A PORTATA PROPORZIONALE

- ad un segnale digitale (contatore lanciimpulsi) con la possibilità di moltiplicare o dividere impulsi ricevuti (4:1 - 1:1 - 10:1 - 1xN)
- ad un segnale analogico (4÷20 mA) con la possibilità di regolare in percentuale la portata massima
- regolazione manuale della portata 0÷100%, funzione costante

● ANALOGIC WITH PROPORTIONAL FLOW

- to a digital signal (water meter) with the possibility multiply or divide the impulses received (4:1-1:1-10:1-1xN)
- to an analogic signal (4÷20 mA) with the possibility to regulate in percentage the maximum flow
- 0÷100% manual flow regulation, constant function

	PORTATE FLOW RATES	PRESSIONI PRESSURES	CC/IMP. CC/STROKE	CONNESSIONI CONNECTIONS	IMP./MIN STROKES/MIN.	ASSORBIMENTO CONSUPTION	PESO WEIGHT
AT.AM Low Flow	0,4 l/h	20 bar	0,06	4x6 / 4x7	120	14 Watt	3 kg
AT.AM 02	5 l/h	8 bar	0,52	4x6	160	14 Watt	3 kg
AT.AM 03	10 l/h	10 bar	0,55	4x6	300	28 Watt	4 kg

AT.MT

● DIGITALE A PORTATA PROPORZIONALE

- ad un segnale analogico 0/4÷20 mA 20÷4 mA selezionabile
- ad un segnale digitale 1:n ; n:1 ; 1:c (batch) oppure direttamente in ppm
- regolazione digitale della portata, con possibilità di impostare la portata max

● DIGITAL WITH PROPORTIONAL FLOW

- to an analogic signal 0/4÷20 mA 20÷4 mA selectable
- to a digital signal 1:n ; n:1 ; 1:c (batch) or directly in ppm
- digital flow regulation, with the possibility to set the max flow

	PORTATE FLOW RATES	PRESSIONI PRESSURES	CC/IMP. CC/STROKE	CONNESSIONI CONNECTIONS	IMP./MIN STROKES/MIN.	ASSORBIMENTO CONSUPTION	PESO WEIGHT
AT.MT Low Flow	0,4 l/h	20 bar	0,06	4x6 / 4x7	120	14 Watt	3 kg
AT.MT 02	5 l/h	8 bar	0,52	4x6	160	14 Watt	3 kg
AT.MT 03	10 l/h	10 bar	0,55	4x6	300	28 Watt	4 kg



SISTEMI PER TORRI DI RAFFREDDAMENTO
COOLING TOWERS
ATHENASERIES



POMPE DOSATRICI ELETTROMAGNETICHE ELECTROMAGNETIC DOSING PUMPS

MODELLI E CARATTERISTICHE TECNICHE - MODELS AND TECHNICAL FEATURES



AT.BT

- **DIGITALE CON TIMER INTEGRATO**
- programmazione Giornaliera e Settimanale
- possibilità di Dosaggio ad Intervalli Programmati
- **DIGITAL WITH BUILT-IN TIMER**
- daily and Weekly Programming
- able to Dose with Timed Intervals

	PORTATE FLOW RATES	PRESSIONI PRESSURES	CC/IMP. CC/STROKE	CONNESSIONI CONNECTIONS	IMP./MIN STROKES/MIN.	ASSORBIMENTO CONSUPTION	PESO WEIGHT
AT.AM Low Flow	0,4 l/h	20 bar	0,06	4x6 / 4x7	120	14 Watt	3 kg
AT.AM 02	5 l/h	8 bar	0,52	4x6	160	14 Watt	3 kg
AT.AM 03	10 l/h	10 bar	0,55	4x6	300	28 Watt	4 kg

MODELLI E CARATTERISTICHE TECNICHE - MODELS AND TECHNICAL FEATURES



AT.PR

- **DIGITALE A PORTATA PROPORZIONALE CON STRUMENTO pH/Rx**
- range di misura pH 0÷14 - Rx -999÷+999 mV
- compensazione automatica/manuale della temperatura (pH)
- uscita 4÷20 mA su tutta la scala per registrazione
- Calibrazione automatica/manuale con indicazione efficienza della sonda
- **DIGITAL PROPORTIONAL FLOW WITH pH/Rx INSTRUMENT**
- pH 0÷14 - Rx -999÷+999 mV measuring range
- manual/automatic temperature compensation (pH)
- 4÷20 mA output on all the recording scale
- manual/automatic calibration with probe efficiency evaluation

● FUNZIONE DI COMANDO "TIMER RITARDO DOSAGGIO DELLA POMPA"

● Alcune volte, all'accensione della pompa dosatrice, è necessario attendere la stabilità di misura chimica per effettuare un corretto dosaggio. Per facilitare il lavoro dell'installatore è disponibile un Timer nel Menù Impostazioni per ritardare il dosaggio all'accensione della pompa

● SOFTWARE FUNCTION "TO SET DELAY TIME DOSING ABOUT PUMP"

● Sometimes when switching the dosing pump on, we need to wait for the chemical measure stability in order to make a proper dosage. To make the installer work easy, it is available a Timer into Pump Menu in order to delay dosing action when switching the dosing pump on.

	PORTATE FLOW RATES	PRESSIONI PRESSURES	CC/IMP. CC/STROKE	CONNESSIONI CONNECTIONS	IMP./MIN STROKES/MIN.	ASSORBIMENTO CONSUPTION	PESO WEIGHT
AT.AM 02	5 l/h	8 bar	0,52	4x6	160	14 Watt	3 kg
AT.AM 03	10 l/h	10 bar	0,55	4x6	300	28 Watt	4 kg



SISTEMI PER TORRI DI RAFFREDDAMENTO
COOLING TOWERS

HELIOS.06CTSERIES

SISTEMI DI CONTROLLO CONTROL SYSTEMS



CARATTERISTICHE PRINCIPALI MAIN FEATURES

STRUMENTO DI CONTROLLO MULTIPARAMETRO

● DISPLAY GRAFICO E TASTIERA

-valori simultanei delle misure, temperatura e stato relays.
-Display a 4 linee con 20 caratteri alfanumerici
-7 Pulsanti di controllo per impostazioni e calibrazioni dello strumento

● SCATOLA DI PROTEZIONE E ALIMENTAZIONE

-scatola per montaggio a muro in materiale plastico ip65

● CONTROLLI MANUALI

-i menù user-friendly rendono l'avvio e il controllo del sistema di dosaggio molto semplice

● RAPPORTO DEI DATI

-memoria flash interna per la memorizzazione dei valori misurati

● PORTA SERIALE RS485

-per la configurazione e l'acquisizione in tempo reale da remoto o per la memorizzazione dei dati su pc o portatile.
protocollo di comunicazione MODBUS RTU

● INPUT DI MISURAZIONE

-alta risoluzione di misurazione con controllo qualità delle sonde per pH e ORP

● USCITE RELE'

-4 relè indipendenti con alimentazione dedicata per pH, Cl, funzione blow down, funzione bisettimanale per prodotti algicidi

MULTIPARAMETER CONTROL INSTRUMENT

● GRAPHIC DISPLAY AND KEYPAD

-Simultaneous value of the measure, temperature and relays status
-4 Lines, 20 characters alphanumeric display
-7 control keys for instrument configuration and calibration

● ENCLOSURE BOX AND POWER SUPPLY

-wall mounting PP plastic material IP56 box
-universal power supply 100÷240 Vac, 50/60 Hz

● MANUAL CONTROLS

-the user-friendly programming step menu makes starting up and checking the control and dosing system easy

● DATA LOGGING

-internal flash memory to load record measures values

● RS485 SERIAL PORT

-for set-up and real time data acquisition from remote or for stored data download on a pc or a laptop.
MODBUS RTU communication protocol-

● MEASURE INPUT

-high measuring resolution with probe quality control for pH and orp probes

● RELAY OUTPUTS

-4 independent relays with dedicated power supplies for: Ph, cl, blow down function, biweekly function for algicide product

آتور صنعت
ATOORSANAT



PREPARATORE AUTOMATICO DI SOLUZIONI POLIELETTROLITICHE
AUTOMATIC CONTINUOUS FLOW POLYELECTROLYTE SOLUTION PREPARER

CARATTERISTICHE GENERALI - GENERAL FEATURES



- **PREPARAZIONE AUTOMATICA A FLUSSO CONTINUO** della Soluzione Polielettrolitica partendo dal Polielettrolita in Polvere e Acqua
- **LA POLVERE DI POLIELETTROLITA** viene estratta dalla Tramoggia mediante un Dosatore a vite con Velocità Variabile, trasferendosi sul cono di acqua dell'ugello miscelatore
- a causa della gravità **LA MISCELA OTTENUTA** cade nella prima vasca di preparazione e successivamente passa, per mezzo dei Sifoni, nelle Vasche di Maturazione e Dosaggio
- Tali **VASCHE DI PREPARAZIONE E MATURAZIONE** sono dotate di Agitatori, altresì presenti come possibile Opzione nelle Vasche di Dosaggio
- **IL VOLUME DEI DEPOSITI E L'AZIONE CONTINUA DEGLI AGITATORI** garantisce l'ottenimento di una Miscela Omogenea nonché un tempo di ritenzione idoneo per la Perfetta Diluizione
- **IL QUADRO ELETTRICO DI CONTROLLO E COMANDO** è finalizzato alla totale Automattizzazione del Sistema, garantendo la corretta Preparazione e il giusto Dosaggio
- **AUTOMATIC CONTINUOUS FLOW PREPARATION** of a Polyelectrolyte Solution, starting from the Polyelectrolyte in Powder Form and Water
- **THE POLYELECTROLYTE POWDER** is extracted from the storage Hopper using a batching screw with Variable Speed, moving to the mixer nozzle water cone
- Because of gravity **THE MIXTURE OBTAINED** falls into the first Preparation Tanks and then passes through the traps into the Maturing and Batching Tanks
- These **PREPARATION AND MATURING TANKS** are equipped with Stirrers, also present as a possible optional in the Batching Tanks
- **THE VOLUME OF THE DEPOSITS AND CONTINUOUS ACTION** of the Stirres ensures that a Homogenous Mixture is obtained and that the retention time is suitable for Perfect Dilution
- **THE ELECTRICAL CONTROL PANEL** ensures total System Automation, guaranteeing correct Preparation and the right Batching



APPLICAZIONI APPLICATIONS

● L'IMPIEGO DI POLIMERI E FLOCCULANTI FAVORISCE IN MODO CONSIDEREVOLE I PROCESSI DI DISTINZIONE TRA LE FASI SOLIDA/LIQUIDA NELLE SEGUENTI APPLICAZIONI:

- Trattamento Acque Potabili e Industriali di Lavorazione
- Depurazione Acque Reflue, in particolare contestualmente a Trattamenti Fisico-Chimici
- Trattamento di Fanghi, al fine di migliorare il rendimento di Centrifughe e Filtri Pressa
- Processi per Industria Cartaria, Chimica, Petrochimica, Trattamento di Minerali, Conserviere, ecc.

● THE USE OF POLYMERS AND FLOCCULANTS CONSIDERABLY FACILITATES THE PROCESSES OF DISTINGUISHING BETWEEN SOLID/LIQUID PHASES IN THE FOLLOWING EXAMPLES APPLICATIONS:

- Treating Drinking and Industrial Processing Water
- Purifying Waste Water, in particular within Physicochemical Treatment
- Treating Sludge, in order to improve the performance of Centrifuges and Filter Presses
- Processes for the Paper, Chemical, Petrochemical, Mineral Processing, Canning Industries etc.

DIMENSIONI E CARATTERISTICHE TECNICHE DIMENSIONS AND TECHNICAL FEATURES

- ➔ INGRESSO ACQUA WATER INLET
- ➔ SVUOTAMENTO EMPTYING
- ➔ ASPIRAZIONE BOMBOLA CYLINDER EXTRACTION
- ➔ TROPPOPIENO OVERFLOW

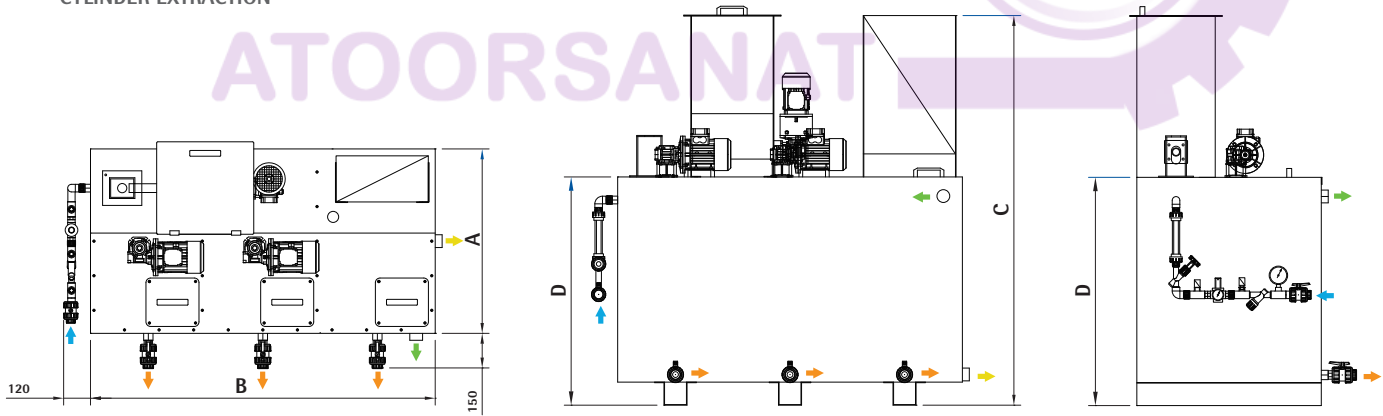

A=Profondità Depth B=Larghezza Width C=Altezza Height D=Diametro Collettore Collector Diameter

MODELLI MODELS	PORTATE FLOW RATES lt	A mm	B mm	C mm	D mm	INGRESSO ACQUA WATER INLET	ASPIRAZIONE BOMBOLA CYLINDER EXTRACTION	SVUOTAMENTO EMPTYING	TROPPOPIENO OVERFLOW
MIX.05	550	800	1000	1690	990	3/4"	1 1/2"	1"	1 1/2"
MIX.08	850	800	1500	1690	990	3/4"	1 1/2"	1"	1 1/2"
MIX.11	1100	800	2000	1690	990	3/4"	1 1/2"	1"	1 1/2"
MIX.15	1500	800	2500	1690	990	3/4"	1 1/2"	1"	1 1/2"
MIX.20	2000	1150	2000	1800	1100	1"	2"	1"	2"
MIX.30	3000	1150	3000	1800	1100	1"	2"	1"	2"



GEMINISERIES

POMPE PNEUMATICHE A DOPPIA MEMBRANA
PNEUMATIC DOUBLE DIAPHRAGM PUMPS



CARATTERISTICHE GENERALI - GENERAL FEATURES

- **IL PROGETTO DELLE NUOVE POMPE A DOPPIA MEMBRANA GEMINISERIES** si è principalmente sviluppato attorno al Sistema di Distribuzione dell'Aria, all'alta tecnologia delle Membrane, alla Geometria delle Camere di Pompaggio e del Sistema Valvole; questo allo scopo di ampliare le funzionalità, nn solo per il Trasferimento ma anche per il Dosaggio. Il risultato ottenuto è un prodotto innovativo con sluzioni di ultima generazione
 - **MATERIALI DI COSTRUZIONE: PP, PVDF, AISI316, ALLUMINIO**
 - **AUTOADESCANTE A SECCO FINO A 6 mt**
 - **FUNZIONAMENTO A SECCO ILLIMITATO**
 - **CIRCUITO PNEUMATICO ANTISTALLO E DI FACILE MANUTENZIONE**
 - **POSSIBILITÀ DI REGOLAZIONE DI: PORTATA, PREVALENZA E VELOCITÀ**
 - **MOLTEPLICI VARIANTI DI INSTALLAZIONI E CONFIGURAZIONI**
 - **CERTIFICAZIONI ATEX PER ZONA 1 E 2 IN TUTTE LE VERSIONI**
 - **COPERCHIO DI SCARICO CON CONNESSIONI PER VARI UTILIZZI**
-
- **THE DRAFT OF THE GEMINISERIES NEW DOUBLE DIAPHRAGM PUMPS**, it is mainly developed around the air distribution system, the diaphragm's high technology, the pumping chambers geometry and the valves system; this in order to extend the functionality, not only for transfer but also for dosing. The result is an innovative product with next-generation solutions.
 - **CONSTRUCTION'S MATERIALS: PP,PVDF, AISI 316, ALUMINIUM**
 - **SELF-PRIMING UP TO 6M**
 - **UNLIMITED DRY RUNNING**
 - **ANTI-STALL PNEUMATIC CIRCUIT , EASY TO MAINTAIN**
 - **POSSIBILITY TO ADJUST: FLOW-RATE, HEAD AND SPEED**
 - **VARIOUS INSTALLATIONS AND CONFIGURATIONS**
 - **ATEX CERTIFICATIONS FOR ZONE 1 AND 2 IN ALL VERSIONS**
 - **AIR-DISCHARGE'S COVER WITH CONNECTIONS FOR VARIOUS USES**

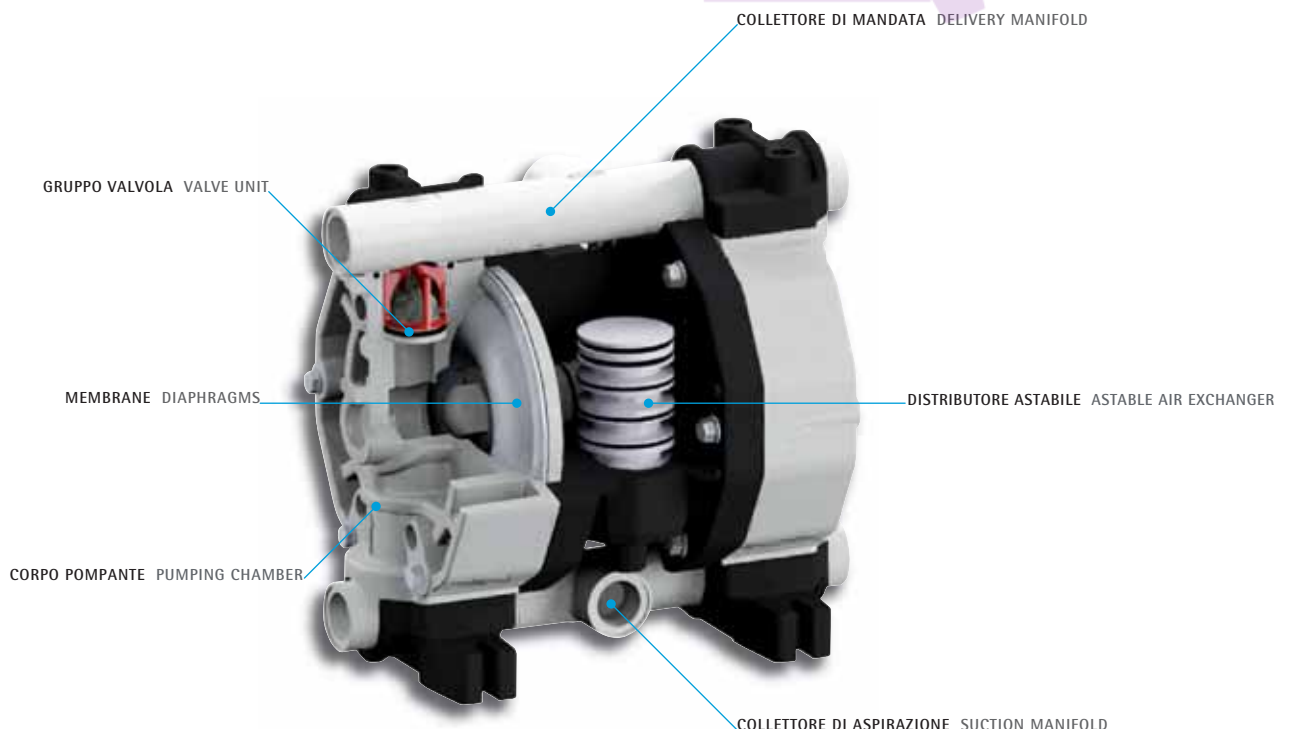



GEMINI.P7SERIES

Antideflagrante Explosion proof

MODELLI E MATERIALI MODELS AND MATERIALS



PVDF+CF



POMc



AISI

CARATTERISTICHE FEATURES

- Compatta
- Prestazioni elevate
- Massima affidabilità
- Vari materiali di costruzione
- disponibile versione antideflagrante

- Compact
- High performances
- Max reliability
- Various construction materials
- ATEX explosion-proof version available

SPECIFICHE SPECIFICATIONS

- Conessioni Liquidi: 1/4" BSP
- Conessioni Aria: 4mm
- Portata massima: 8lt/min
- Pressione massima aria: 8 Bar
- Prevalenza massima: 80 Mt
- Aspirazione massima a secco: 3 mt
- Aspirazione massima carica 9,8 mt
- Passaggio solidi: 2,5 mm
- Rumorosità: 62 dB
- Quantitativo per ciclo: 8cc
- Viscosità max: 6000 cps

- Fluids connections: 1/4" BSP
- Air connection: 4mm
- Max Flow-rate: 8lt/min
- Max air pressure: 8 Bar
- Max delivery head: 80 Mt
- Max suction lift DRY: 3 mt
- Max suction lift WET: 9,8 mt
- Max solid passing: 2,5 mm
- Noise: 62 dB
- Displacement per cycle: 8cc
- Max viscosity: 6000 cps

DIMENSIONI DIMENSIONS

A (mm)	129	129	129
B (mm)	68	68	68
C (mm)	112	112	112
PESO Weight (Kg)	0,9	0,7	0,9
TEMP. MAX MAX TEMP.	65°C	95°C	95°C

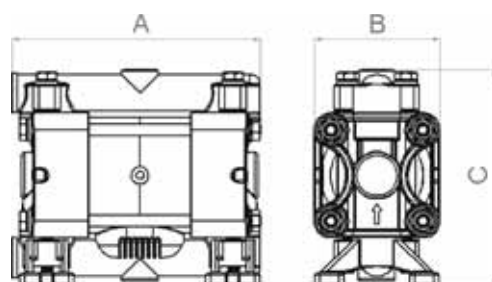



GEMINI.P18SERIES

Antideflagrante Explosion proof

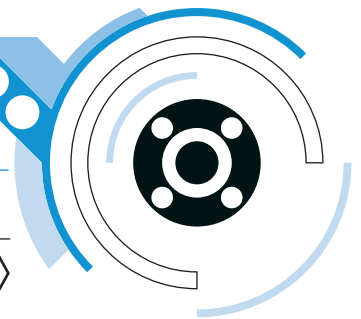

MODELLI E MATERIALI MODELS AND MATERIALS



PVDF+CF



POMc



AISI

CARATTERISTICHE TECNICHE TECHNICAL FEATURES

CONNESSIONI CONNECTIONS	3/8" BSP
PORTATA MAX MAX FLOW RATE	18 lt/min
PREVALENZA MAX MAX HEAD	70 m
PRESSIONE MAX MAX PRESSURE	7 bar
ATTACCO ARIA AIR CONNECTION	6 mm
CAPACITÀ DI ASPIRAZIONE SUCTION HEIGHT	6 m
SOLIDI DI PASSAGGIO PASSING SOLIDS	3 mm

Le curve e le prestazioni sono riferite a pompe con aspirazione immersa e bocca di mandata libera, con acqua a 20°C e variano in funzione dei materiali di composizione

The curves and performance values refer to pumps with submerged suction and a free delivery outlet with water at 20°C, and vary according to the construction material.

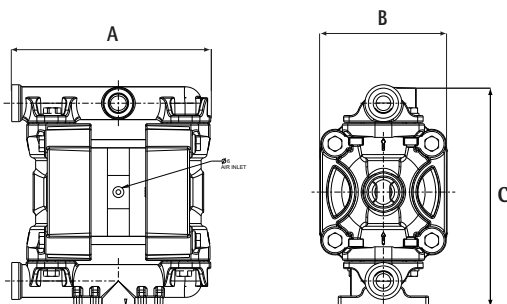
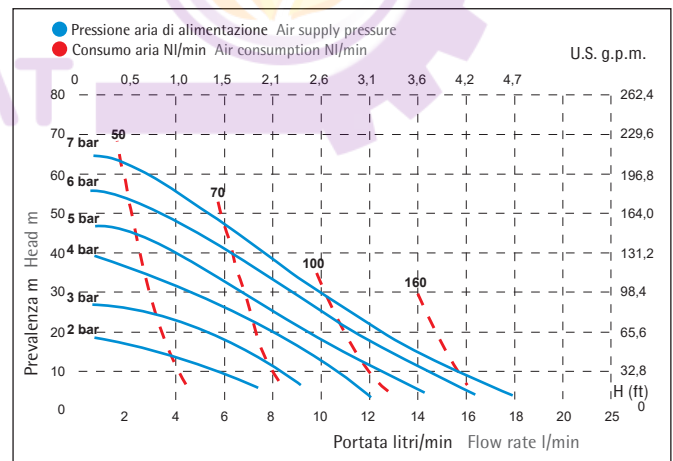

	PP	PVDF	POM	AISI316
A (mm)	145	145	145	145
B (mm)	95	95	95	95
C (mm)	160	160	160	160
PESO WEIGHT (Kg)	2	2,5	2	3
TEMP. MAX MAX TEMP.	65°C	95°C	95°C	95°C

Connessioni flangiate ISO-ANSI disponibili su richiesta
ISO-ANSI flanged connections available upon request



GEMINI.P30 SERIES

Ex Antideflagrante Explosion proof

MODELLI E MATERIALI MODELS AND MATERIALS



PVDF+CF



POMc



AISI

CARATTERISTICHE FEATURES

- Performance elevate
- Massima affidabilità
- Diversi materiali di costruzione
- Fedele alle normative ATEX
- High performances
- Max reliability
- Various construction materials
- ATEX Compliant

SPECIFICHE SPECIFICATIONS

- Conessioni per fluido: 1/2" BSP
- Connessione aria: 6mm
- Portata massima: 35 lt/min
- Pressione massima aria: 8 Bar
- Prevalenza massima: 80 Mt
- Aspirazione massima a secco: 5 mt
- Aspirazione massima in carico: 9,8 mt
- Passaggio solidi : 3,5 mm
- Rumorosità: 65 dB
- Erogazione per ciclo: 50cc
- Viscosità massima: 15.000 cps
- Fluids connections: 1/2" BSP
- Air connection: 6mm
- Max Flow-rate: 35 lt/min
- Max air pressure: 8 Bar
- Max delivery head: 80 Mt
- Max suction lift DRY: 5 mt
- Max suction lift WET: 9,8 mt
- Max solid passing: 3,5 mm
- Noise: 65 dB
- Displacement per cycle: 50cc
- Max viscosity: 15.000 cps

DIMENSIONI DIMENSIONS

	PP	PVDF	POMc	AISI
A (mm)	177	177	177	182
B (mm)	105	105	105	104
C (mm)	183	183	183	190
PESO Weight (Kg)	1,4	1,7	1,4	2,4
TEMP. MAX MAX TEMP.	65°C	95°C	95°C	95°C

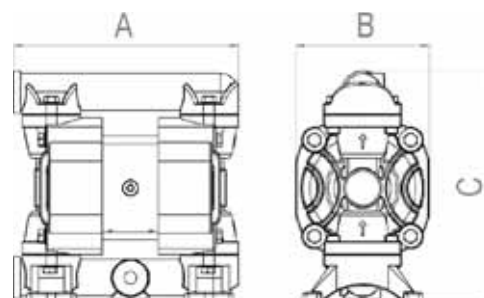



GEMINI.P50 SERIES

Ex Antideflagrante Explosion proof

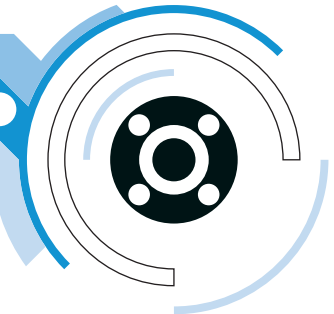

MODELLI E MATERIALI MODELS AND MATERIALS

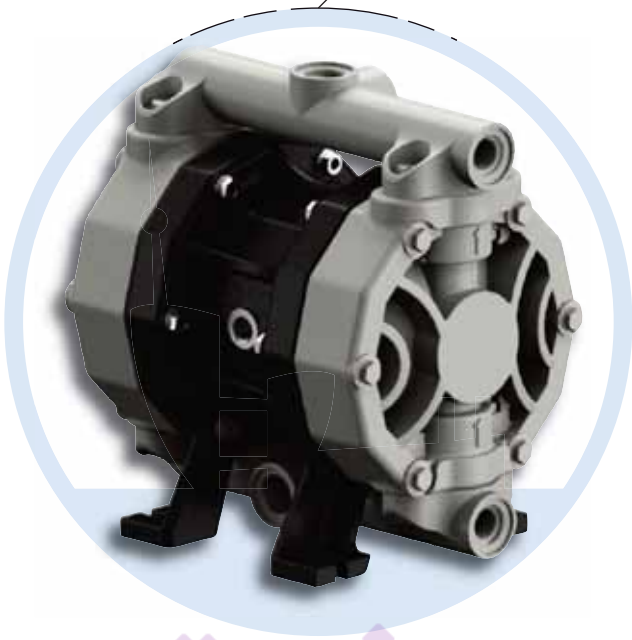

PVDF+CF



Alu



SS316

CARATTERISTICHE TECNICHE TECHNICAL FEATURES

CONNESSIONI CONNECTIONS	1/2" BSP
PORTATA MAX MAX FLOW RATE	50 lt/min
PREVALENZA MAX MAX HEAD	70 m
PRESSIONE MAX MAX PRESSURE	7 bar
ATTACCO ARIA AIR CONNECTION	1/4" BSP
CAPACITÀ DI ASPIRAZIONE SUCTION HEIGHT	6 mm
SOLIDI DI PASSAGGIO PASSING SOLIDS	3 mm

Le curve e le prestazioni sono riferite a pompe con aspirazione immersa e bocca di mandata libera, con acqua a 20°C e variano in funzione dei materiali di composizione

The curves and performance values refer to pumps with submerged suction and a free delivery outlet with water at 20°C, and vary according to the construction material.

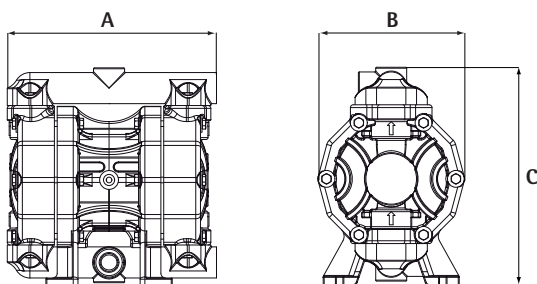
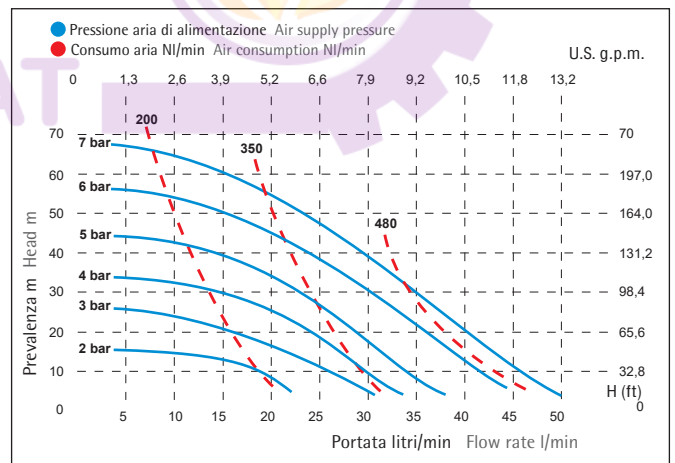

	PP	PVDF	POM	POM
A (mm)	222	222	225	225
B (mm)	156	156	156	156
C (mm)	233	233	230	230
PESO WEIGHT (Kg)	4	4,5	5	6
TEMP. MAX MAX TEMP.	65°C	95°C	95°C	95°C

Connessioni flangiate ISO-ANSI disponibili su richiesta
ISO-ANSI flanged connections available upon request



INDUSTRIAL DIVISION GEMINI.P65 SERIES

Ex Antideflagrante Explosion proof

MODELLI E MATERIALI MODELS AND MATERIALS

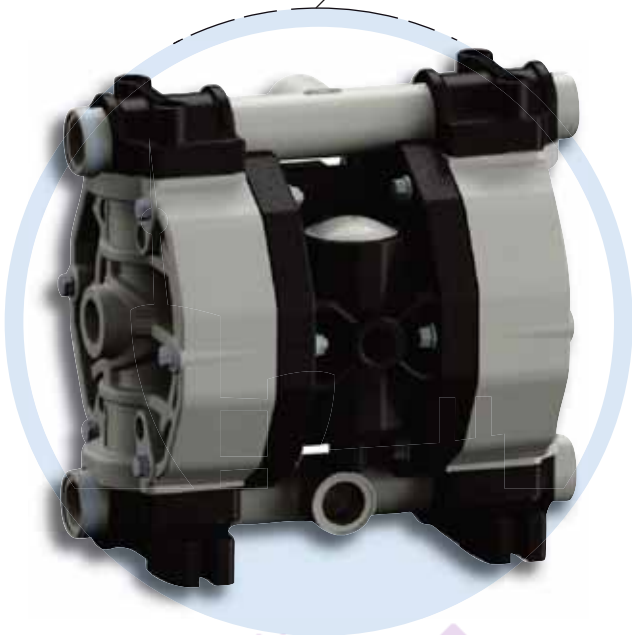

PVDF+CF



Alu



SS316

CARATTERISTICHE TECNICHE TECHNICAL FEATURES

CONNESSIONI CONNECTIONS	1/2" BSP
PORTATA MAX MAX FLOW RATE	65 lt/min
PREVALENZA MAX MAX HEAD	70 m
PRESSIONE MAX MAX PRESSURE	7 bar
ATTACCO ARIA AIR CONNECTION	1/2" BSP
CAPACITÀ DI ASPIRAZIONE SUCTION HEIGHT	6 mm
SOLIDI DI PASSAGGIO PASSING SOLIDS	3,5 mm

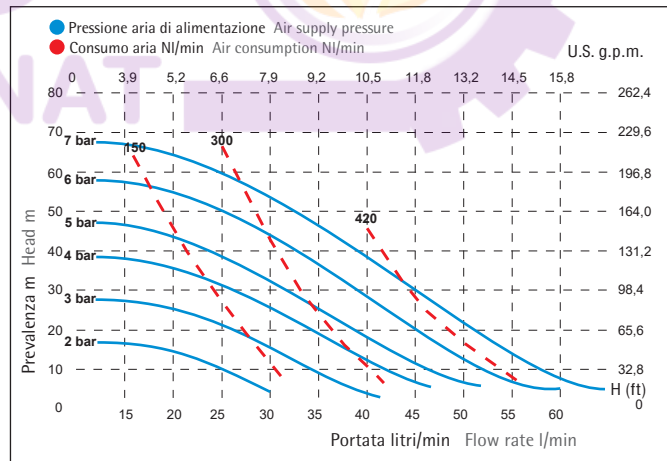

Le curve e le prestazioni sono riferite a pompe con aspirazione immersa e bocca di mandata libera, con acqua a 20°C e variano in funzione dei materiali di composizione

The curves and performance values refer to pumps with submerged suction and a free delivery outlet with water at 20°C, and vary according to the construction material.

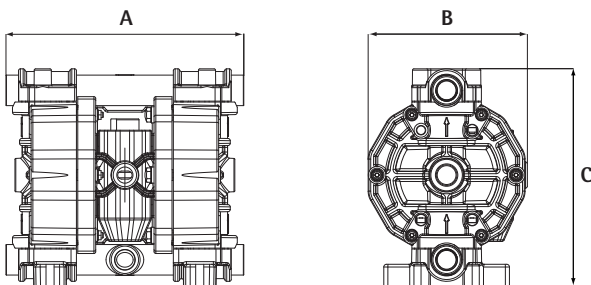

	PP	PVDF	POM	POM
A (mm)	265	265	265	250
B (mm)	175	175	175	175
C (mm)	245	245	245	250
PESO WEIGHT (Kg)	6,5	7	7	7
TEMP. MAX MAX TEMP.	65°C	95°C	95°C	95°C

Connessioni flangiate ISO-ANSI disponibili su richiesta
ISO-ANSI flanged connections available upon request



GEMINI.P100SERIES

Ex Antideflagrante Explosion proof

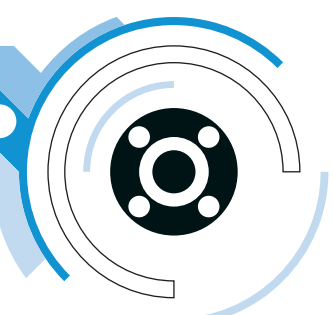

MODELLI E MATERIALI MODELS AND MATERIALS



PVDF+CF



Alu



SS316

CARATTERISTICHE TECNICHE TECHNICAL FEATURES

CONNESSIONI CONNECTIONS	3/4" BSP
PORTATA MAX MAX FLOW RATE	100 lt/min
PREVALENZA MAX MAX HEAD	70 m
PRESSIONE MAX MAX PRESSURE	7 bar
ATTACCO ARIA AIR CONNECTION	1/2" BSP
CAPACITÀ DI ASPIRAZIONE SUCTION HEIGHT	6 mm
SOLIDI DI PASSAGGIO PASSING SOLIDS	3,5 mm

Le curve e le prestazioni sono riferite a pompe con aspirazione immersa e bocca di mandata libera, con acqua a 20°C e variano in funzione dei materiali di composizione.
The curves and performance values refer to pumps with submerged suction and a free delivery outlet with water at 20°C, and vary according to the construction material.

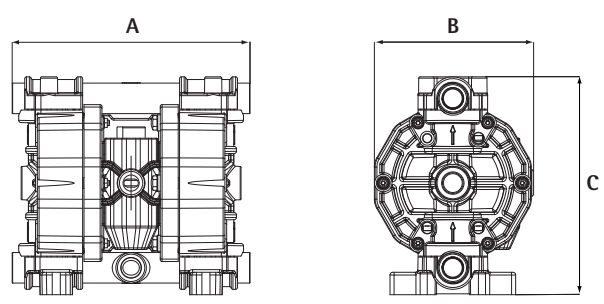
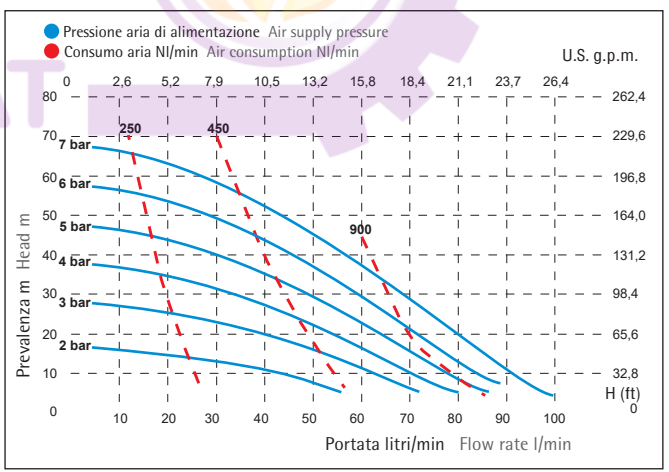

	PP	PVDF	POM	POM
A (mm)	265	265	265	250
B (mm)	175	175	175	175
C (mm)	245	245	245	250
PESO WEIGHT (Kg)	6,5	7	7	9
TEMP. MAX MAX TEMP.	65°C	95°C	95°C	95°C

Connessioni flangiate ISO-ANSI disponibili su richiesta
ISO-ANSI flanged connections available upon request



INDUSTRIAL DIVISION GEMINI.P160 SERIES

Ex Antideflagrante Explosion proof

MODELLI E MATERIALI MODELS AND MATERIALS



PVDF+CF



Alu



SS316

CARATTERISTICHE TECNICHE TECHNICAL FEATURES

CONNESSIONI CONNECTIONS	1" BSP
PORTATA MAX MAX FLOW RATE	160 lt/min
PREVALENZA MAX MAX HEAD	70 m
PRESSIONE MAX MAX PRESSURE	7 bar
ATTACCO ARIA AIR CONNECTION	1/2" BSP
CAPACITÀ DI ASPIRAZIONE SUCTION HEIGHT	6 mm
SOLIDI DI PASSAGGIO PASSING SOLIDS	7,5 mm

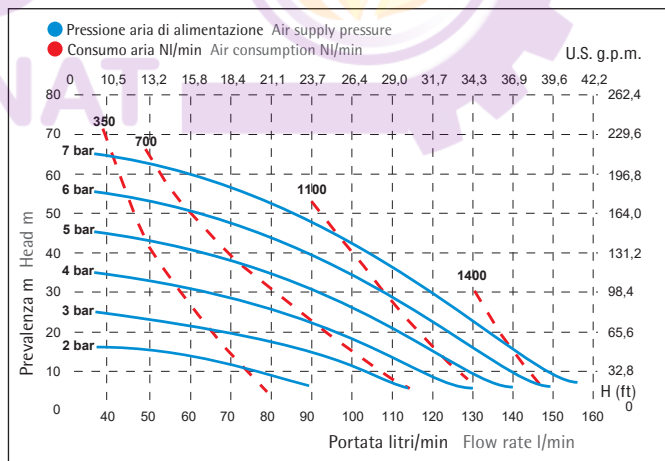

Le curve e le prestazioni sono riferite a pompe con aspirazione immersa e bocca di mandata libera, con acqua a 20°C e variano in funzione dei materiali di composizione

The curves and performance values refer to pumps with submerged suction and a free delivery outlet with water at 20°C, and vary according to the construction material.

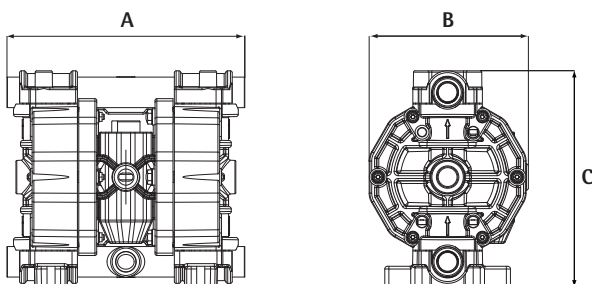

	PP	PVDF	POM	POM
A (mm)	370	370	370	360
B (mm)	220	220	220	220
C (mm)	364	364	364	365
PESO WEIGHT (Kg)	15	16	16	20
TEMP. MAX MAX TEMP.	65°C	95°C	95°C	95°C

Connessioni flangiate ISO-ANSI disponibili su richiesta
ISO-ANSI flanged connections available upon request



GEMINI.P250SERIES

Antideflagrante Explosion proof

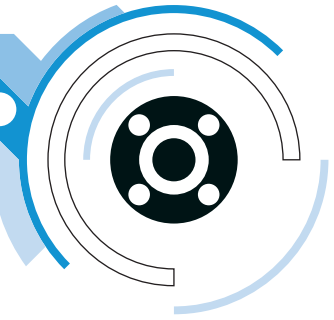

MODELLI E MATERIALI MODELS AND MATERIALS

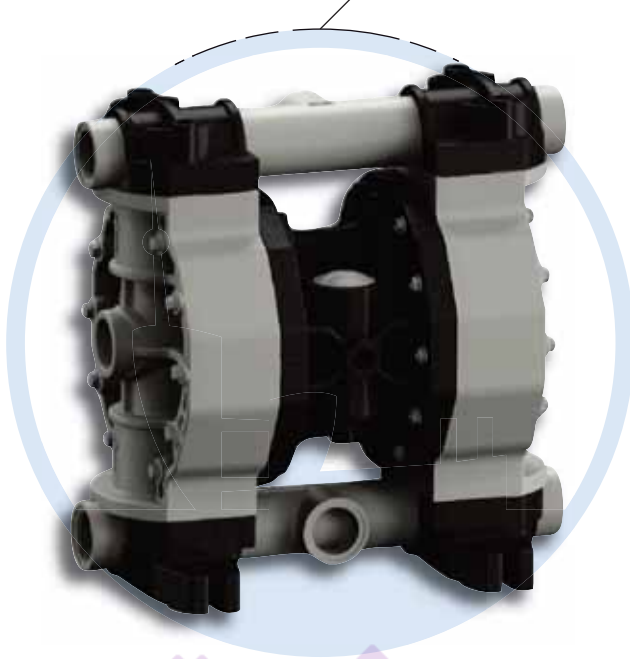

PVDF+CF



Alu



SS316

CARATTERISTICHE TECNICHE TECHNICAL FEATURES

CONNESSIONI CONNECTIONS	1 1/4" BSP
PORTATA MAX MAX FLOW RATE	250 lt/min
PREVALENZA MAX MAX HEAD	70 m
PRESSIONE MAX MAX PRESSURE	7 bar
ATTACCO ARIA AIR CONNECTION	1/2" BSP
CAPACITÀ DI ASPIRAZIONE SUCTION HEIGHT	6 mm
SOLIDI DI PASSAGGIO PASSING SOLIDS	7,5 mm

Le curve e le prestazioni sono riferite a pompe con aspirazione immersa e bocca di mandata libera, con acqua a 20°C e variano in funzione dei materiali di composizione

The curves and performance values refer to pumps with submerged suction and a free delivery outlet with water at 20°C, and vary according to the construction material.

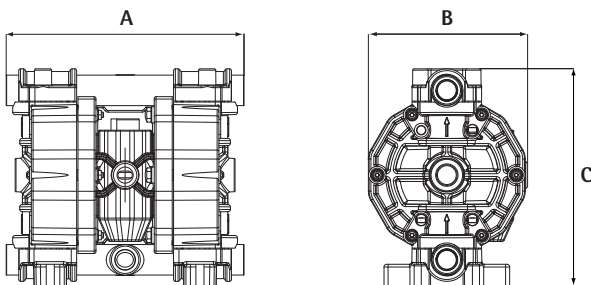
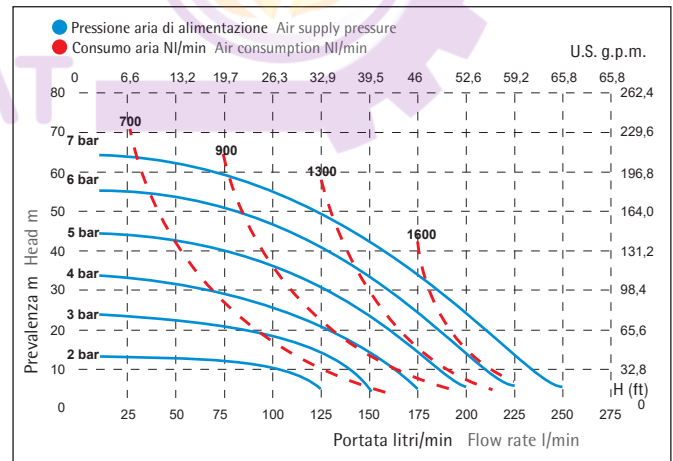

	PP	PVDF	POM	POM
A (mm)	370	370	370	360
B (mm)	220	220	220	220
C (mm)	364	364	364	365
PESO WEIGHT (Kg)	15	16	16	20
TEMP. MAX MAX TEMP.	65°C	95°C	95°C	95°C

Connessioni flangiate ISO-ANSI disponibili su richiesta
ISO-ANSI flanged connections available upon request



INDUSTRIAL DIVISION GEMINI.P500 SERIES

Ex Antideflagrante Explosion proof

MODELLI E MATERIALI MODELS AND MATERIALS



PVDF+CF



Alu



SS316

CARATTERISTICHE TECNICHE TECHNICAL FEATURES

CONNESSIONI CONNECTIONS	DN40 (1 1/2" BSP)*
PORTATA MAX MAX FLOW RATE	500 lt/min
PREVALENZA MAX MAX HEAD	70 m
PRESSIONE MAX MAX PRESSURE	7 bar
ATTACCO ARIA AIR CONNECTION	3/4" BSP
CAPACITÀ DI ASPIRAZIONE SUCTION HEIGHT	6 mm
SOLIDI DI PASSAGGIO PASSING SOLIDS	8,5 mm

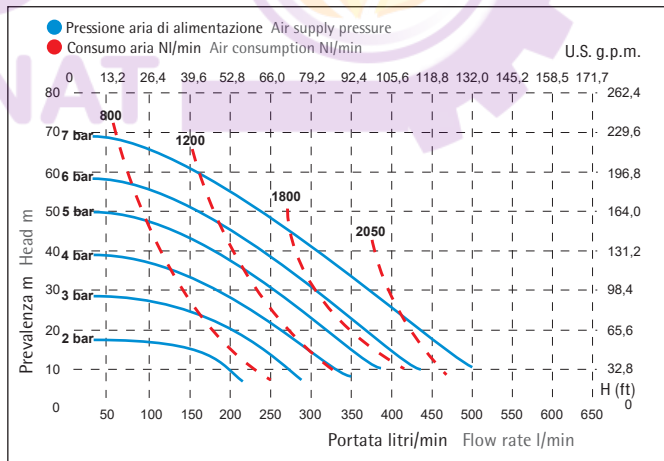

Le curve e le prestazioni sono riferite a pompe con aspirazione immersa e bocca di mandata libera, con acqua a 20°C e variano in funzione dei materiali di composizione

The curves and performance values refer to pumps with submerged suction and a free delivery outlet with water at 20°C, and vary according to the construction material.

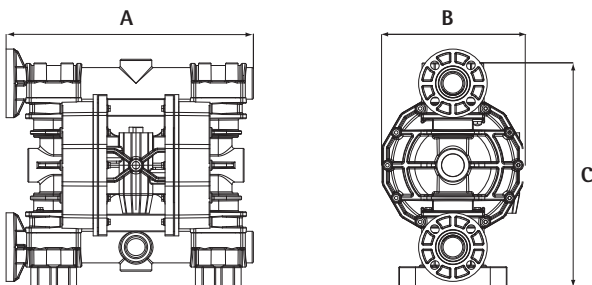

	PP	PVDF	POM	POM
A (mm)	595	595	595	582
B (mm)	340	340	340	345
C (mm)	565	565	245	570
PESO WEIGHT (Kg)	30	30	35	58
TEMP. MAX MAX TEMP.	65°C	95°C	95°C	95°C

(*) Connessioni filettate disponibili su richiesta
(* Threaded connections available upon request)



GEMINI.P700 SERIES

Ex Antideflagrante Explosion proof

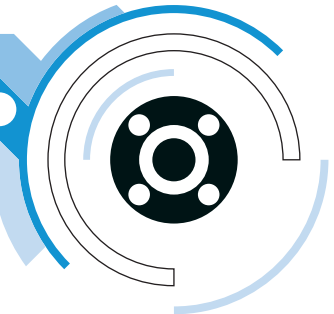

MODELLI E MATERIALI MODELS AND MATERIALS



PVDF+CF



Alu



SS316

CARATTERISTICHE TECNICHE TECHNICAL FEATURES

CONNESSIONI CONNECTIONS	DN50 (2" BSP)*
PORTATA MAX MAX FLOW RATE	680 lt/min
PREVALENZA MAX MAX HEAD	70 m
PRESSIONE MAX MAX PRESSURE	7 bar
ATTACCO ARIA AIR CONNECTION	3/4" BSP
CAPACITÀ DI ASPIRAZIONE SUCTION HEIGHT	6 mm
SOLIDI DI PASSAGGIO PASSING SOLIDS	8,5 mm

Le curve e le prestazioni sono riferite a pompe con aspirazione immersa e bocca di mandata libera, con acqua a 20°C e variano in funzione dei materiali di composizione

The curves and performance values refer to pumps with submerged suction and a free delivery outlet with water at 20°C, and vary according to the construction material.

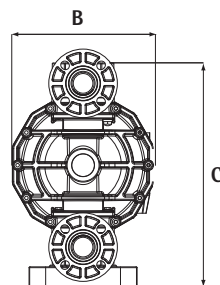
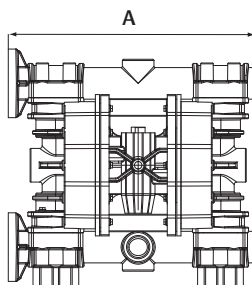
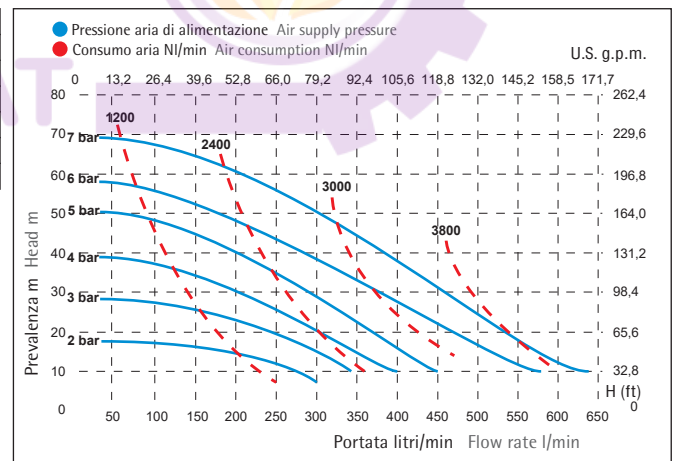

	PP	PVDF	POM	POM
A (mm)	595	595	595	582
B (mm)	340	340	340	345
C (mm)	565	565	245	570
PESO WEIGHT (Kg)	31	36	36	60
TEMP. MAX MAX TEMP.	65°C	95°C	95°C	95°C

(*) Connessioni filettate disponibili su richiesta
(*) Threaded connections available upon request



INDUSTRIAL DIVISION

GEMINI.FOODSERIES

POMPE PNEUMATICHE A DOPPIA MEMBRANA
PNEUMATIC DOUBLE DIAPHRAGM PUMPS

 Antideflagrante Explosion proof

CARATTERISTICHE GENERALI GENERAL FEATURES

- **LE POMPE PNEUMATICHE A DOPPIA MEMBRANA GEMINI.FOODSERIES** grazie alle loro caratteristiche costruttive, possono essere utilizzate per la movimentazione ed il pompaggio di prodotti destinati **ALL'INDUSTRIA ALIMENTARE E COSMETICA**. Realizzate con materiali Costruttivi Certificati FDA.

Le parti a contatto con il fluido, infatti, sono esclusivamente in AISI316 elettrolucidato e PTFE, entrambi certificati per utilizzo alimentare.

Queste pompe, sono in grado di movimentare fluidi con viscosità molto elevate e temperature che possono raggiungere i 95°C

- **MATERIALI DI COSTRUZIONE: AISI316 ELETTRUCIDATO CON RUGOSITÀ MEDIA DI 2,7 μm**
- **AUTODESCANTE A SECCO FINO A 6 mt**
- **FUNZIONAMENTO A SECCO ILLIMITATO**
- **CIRCUITO PNEUMATICO ANTISTALLO E DI FACILE MANUTENZIONE**
- **POSSIBILITÀ DI REGOLAZIONE DI: PORTATA, PREVALENZA E VELOCITÀ**
- **MOLTEPLICI VARIANTI DI INSTALLAZIONI E CONFIGURAZIONI**
- **CERTIFICAZIONI ATEX PER ZONA 1 E 2**
- **COPERCHIO DI SCARICO CON CONNESSIONI PER VARI UTILIZZI**
- **ATTACCO DI ASPIRAZIONE E MANDATA CLAMP**

- **THE AIR-OPERATED DOUBLE DIAPHRAGM PUMPS SERIES GEMINI.FOODSERIES** thanks to their structural characteristics, can be used to pump products used in **FOOD AND COSMETICS INDUSTRY**.

THE GEMINI.FOODSERIES are made with FDA certified construction materials.

The parts in contact with the fluid, in fact, are exclusively electro-polished AISI 316 and PTFE, both certified for food use.

These pumps are able to handling fluids with very high viscosity and temperature up to 95° C.

- **CONSTRUCTION'S MATERIALS: ELECTRO-POLISHED AISI 316, MEDIUM ROUGHNESS IS 2,7 μm**
- **SELF-PRIMING UP TO 6 mt**
- **UNLIMITED DRY RUNNING**
- **ANTI-STALL PNEUMATIC CIRCUIT , EASY TO MAINTAIN**
- **POSSIBILITY TO ADJUST: FLOW-RATE, HEAD AND SPEED**
- **VARIOUS INSTALLATIONS AND CONFIGURATIONS**
- **ATEX CERTIFICATIONS FOR ZONE 1 AND 2 IN ALL VERSIONS**
- **AIR-DISCHARGE'S COVER WITH CONNECTIONS FOR VARIOUS USES**
- **SUCTION AND DELIVERY CONNECTION WITH CLAMP**

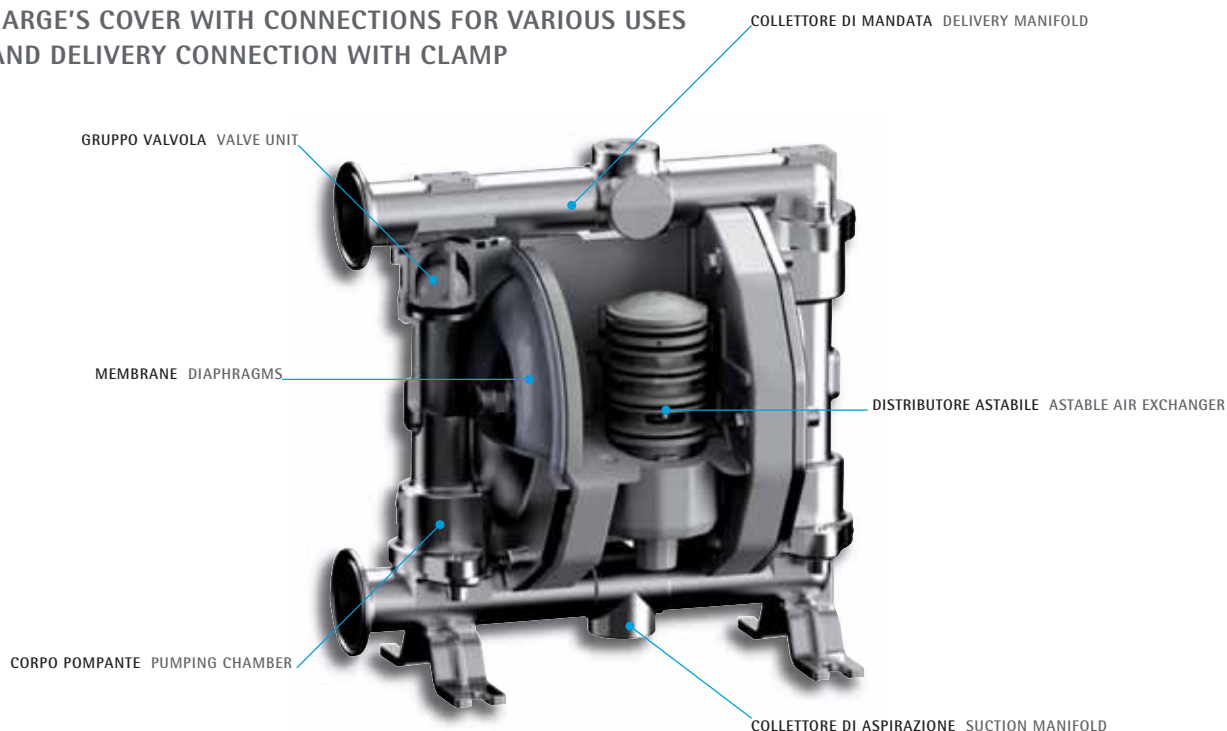



GEMINI.PF50 SERIES

Ex Antideflagrante Explosion proof

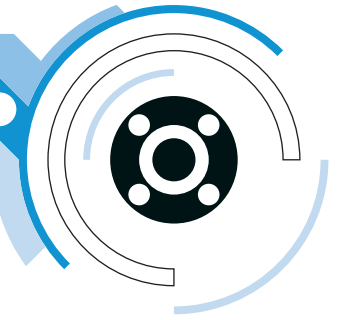

MODELLI MODELS

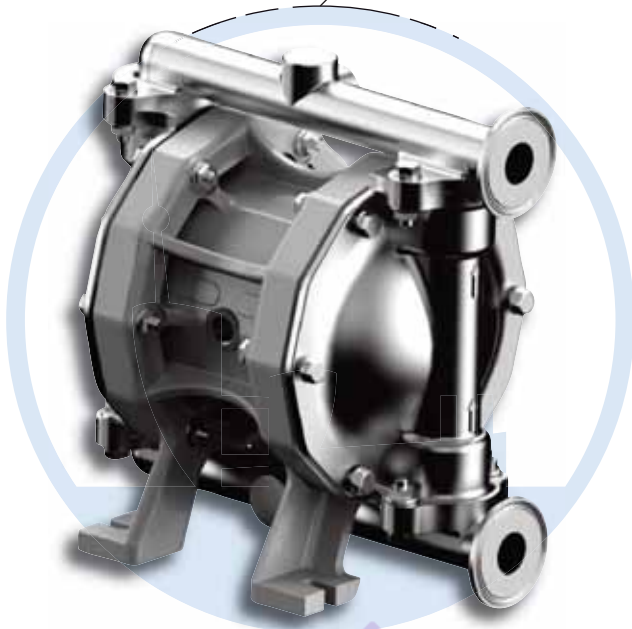

SS316 Elettrolucidato o lucidato meccanicamente

SS316 electropolished or mechanically polished

CARATTERISTICHE TECNICHE TECHNICAL FEATURES

CONNESSIONI CONNECTIONS	CLAMP 1"
PORTATA MAX MAX FLOW RATE	50 lt/min
PREVALENZA MAX MAX HEAD	70 m
PRESSIONE MAX MAX PRESSURE	7 bar
ATTACCO ARIA AIR CONNECTION	1/4" BSP
CAPACITÀ DI ASPIRAZIONE SUCTION HEIGHT	6 mm
SOLIDI DI PASSAGGIO PASSING SOLIDS	3 mm

Le curve e le prestazioni sono riferite a pompe con aspirazione immersa e bocca di mandata libera, con acqua a 20°C e variano in funzione dei materiali di composizione

The curves and performance values refer to pumps with submerged suction and a free delivery outlet with water at 20°C, and vary according to the construction material.

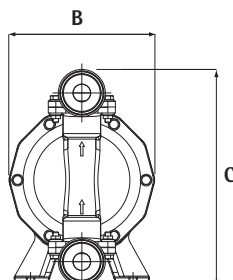
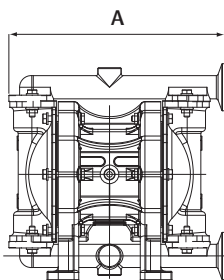
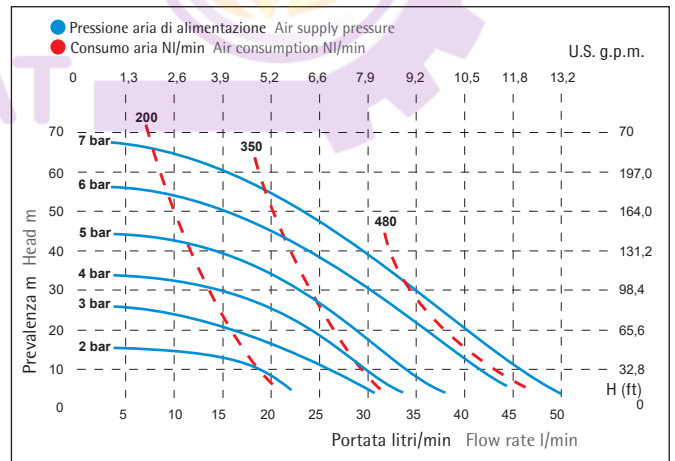

SS316 elettrolucidato	
A (mm)	225
B (mm)	156
C (mm)	230
PESO WEIGHT (Kg)	6
TEMP. MAX MAX TEMP.	95°C

Connezzioni filettate ISO-ANSI disponibili su richiesta
ISO-ANSI threaded connections available upon request



INDUSTRIAL DIVISION GEMINI.PF100 SERIES

Ex Antideflagrante Explosion proof

MODELLI MODELS



SS316 Elettrolucidato o lucidato meccanicamente

SS316 electropolished or mechanically polished

CARATTERISTICHE TECNICHE TECHNICAL FEATURES

CONNESSIONI CONNECTIONS	CLAMP 1"
PORTATA MAX MAX FLOW RATE	100 lt/min
PREVALENZA MAX MAX HEAD	70 m
PRESSIONE MAX MAX PRESSURE	7 bar
ATTACCO ARIA AIR CONNECTION	3/8" BSP
CAPACITÀ DI ASPIRAZIONE SUCTION HEIGHT	6 mm
SOLIDI DI PASSAGGIO PASSING SOLIDS	3,5 mm

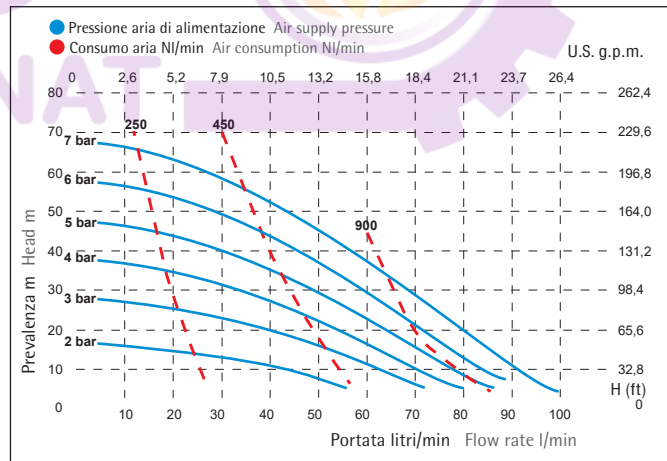

Le curve e le prestazioni sono riferite a pompe con aspirazione immersa e bocca di mandata libera, con acqua a 20°C e variano in funzione dei materiali di composizione

The curves and performance values refer to pumps with submerged suction and a free delivery outlet with water at 20°C, and vary according to the construction material.

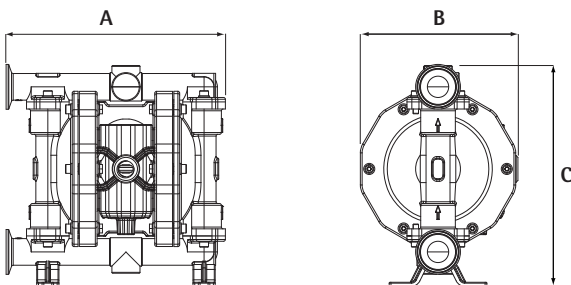

SS316 elettrolucidato	
A (mm)	250
B (mm)	175
C (mm)	250
PESO WEIGHT (Kg)	9
TEMP. MAX MAX TEMP.	95°C

Connessioni flangiate ISO-ANSI disponibili su richiesta
ISO-ANSI flanged connections available upon request



GEMINI.P160SERIES

Ex Antideflagrante Explosion proof

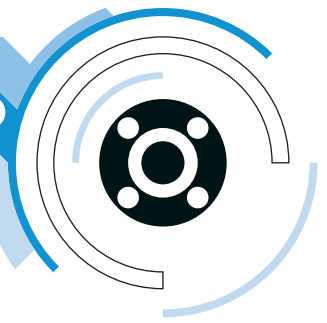

MODELLI MODELS

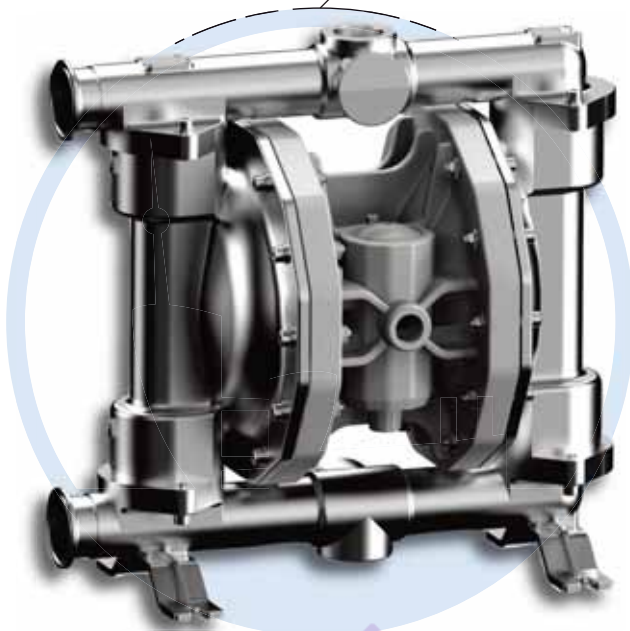

SS316 Elettrolucidato o lucidato meccanicamente

SS316 electropolished or mechanically polished

CARATTERISTICHE TECNICHE TECHNICAL FEATURES

CONNESSIONI CONNECTIONS	CLAMP 1 1/2"
PORTATA MAX MAX FLOW RATE	160 lt/min
PREVALENZA MAX MAX HEAD	70 m
PRESSIONE MAX MAX PRESSURE	7 bar
ATTACCO ARIA AIR CONNECTION	1/2" BSP
CAPACITÀ DI ASPIRAZIONE SUCTION HEIGHT	6 mm
SOLIDI DI PASSAGGIO PASSING SOLIDS	7,5 mm

Le curve e le prestazioni sono riferite a pompe con aspirazione immersa e bocca di mandata libera, con acqua a 20°C e variano in funzione dei materiali di composizione

The curves and performance values refer to pumps with submerged suction and a free delivery outlet with water at 20°C, and vary according to the construction material.

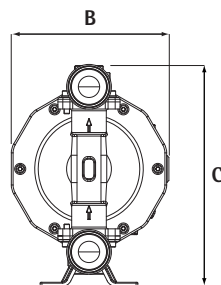
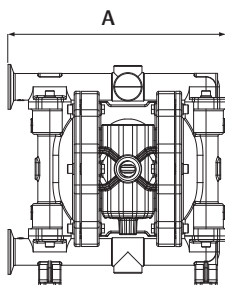
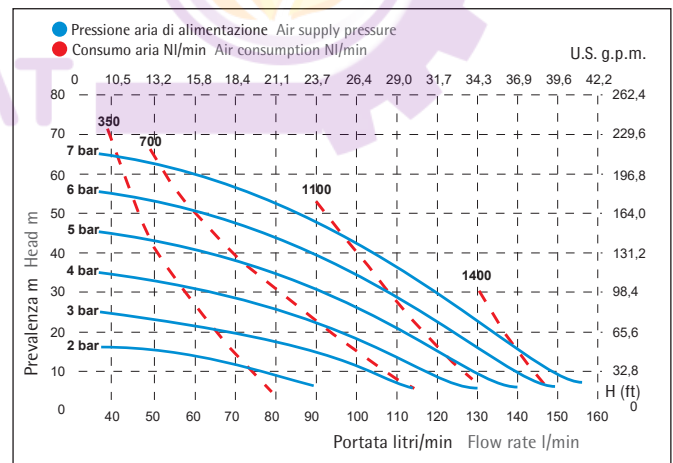

SS316 elettrolucidato	
A (mm)	360
B (mm)	220
C (mm)	365
PESO WEIGHT (Kg)	20
TEMP. MAX MAX TEMP.	95°C

Connessioni flangiate ISO-ANSI disponibili su richiesta
ISO-ANSI flanged connections available upon request



INDUSTRIAL DIVISION

GEMINI.PF500 SERIES

Antideflagrante Explosion proof

MODELLI MODELS

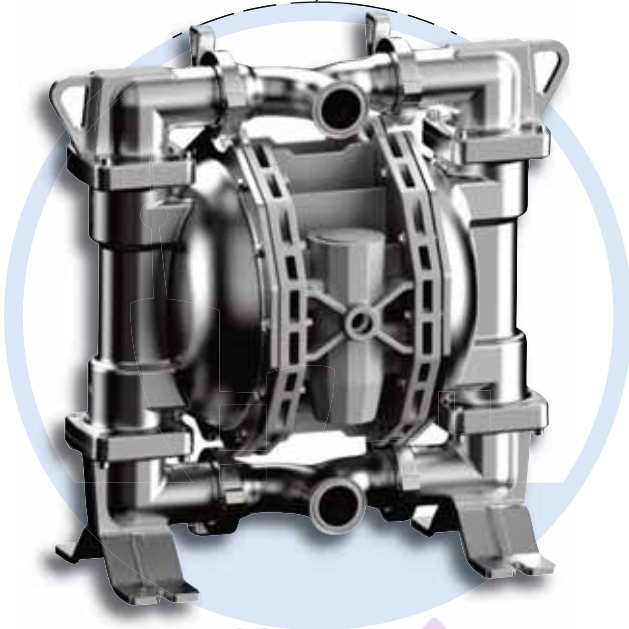

SS316 Elettrolucidato o lucidato meccanicamente

SS316 electropolished or mechanically polished

CARATTERISTICHE TECNICHE TECHNICAL FEATURES

CONNESSIONI CONNECTIONS	CLAMP 2"
PORTATA MAX MAX FLOW RATE	500 lt/min
PREVALENZA MAX MAX HEAD	70 m
PRESSIONE MAX MAX PRESSURE	7 bar
ATTACCO ARIA AIR CONNECTION	3/4" BSP
CAPACITÀ DI ASPIRAZIONE SUCTION HEIGHT	6 mm
SOLIDI DI PASSAGGIO PASSING SOLIDS	8,5 mm

Le curve e le prestazioni sono riferite a pompe con aspirazione immersa e bocca di mandata libera, con acqua a 20°C e variano in funzione dei materiali di composizione

The curves and performance values refer to pumps with submerged suction and a free delivery outlet with water at 20°C, and vary according to the construction material.

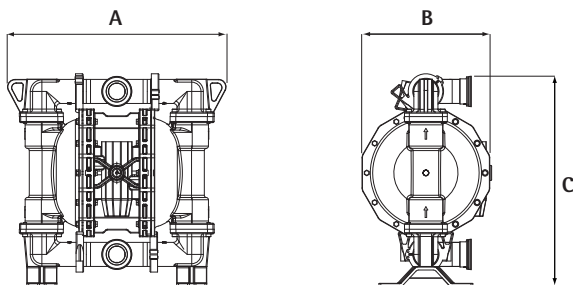
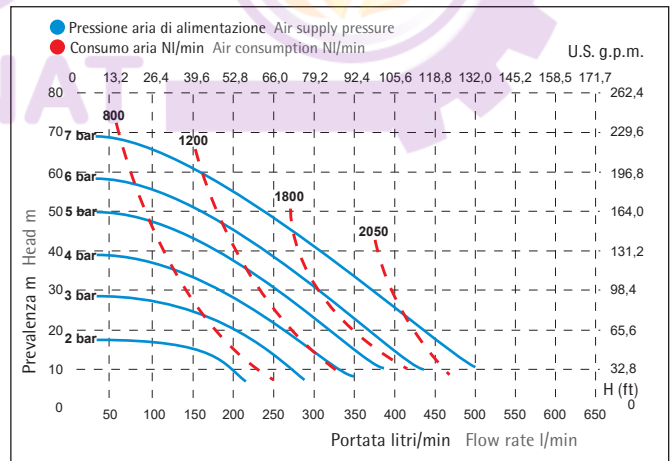

SS316 elettrolucidato	
A (mm)	582
B (mm)	345
C (mm)	570
PESO WEIGHT (Kg)	58
TEMP. MAX MAX TEMP.	95°C

Connessioni filettate ISO-ANSI disponibili su richiesta
ISO-ANSI threaded connections available upon request



GEMINI.P700 SERIES

Antideflagrante Explosion proof

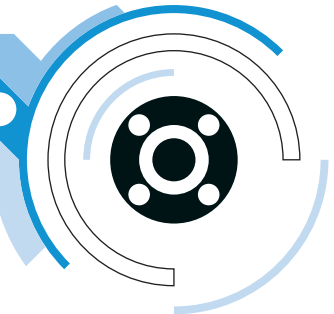

MODELLI MODELS

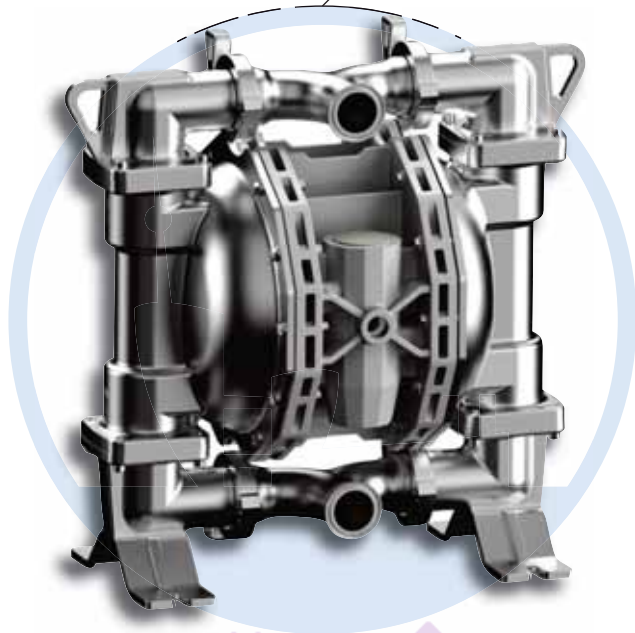

SS316 Elettrolucidato o lucidato meccanicamente

SS316 electropolished or mechanically polished

CARATTERISTICHE TECNICHE TECHNICAL FEATURES

CONNESSIONI CONNECTIONS	CLAMP 2 1/2"
PORTATA MAX MAX FLOW RATE	680 lt/min
PREVALENZA MAX MAX HEAD	70 m
PRESSIONE MAX MAX PRESSURE	7 bar
ATTACCO ARIA AIR CONNECTION	3/4" BSP
CAPACITÀ DI ASPIRAZIONE SUCTION HEIGHT	6 mm
SOLIDI DI PASSAGGIO PASSING SOLIDS	8,5 mm

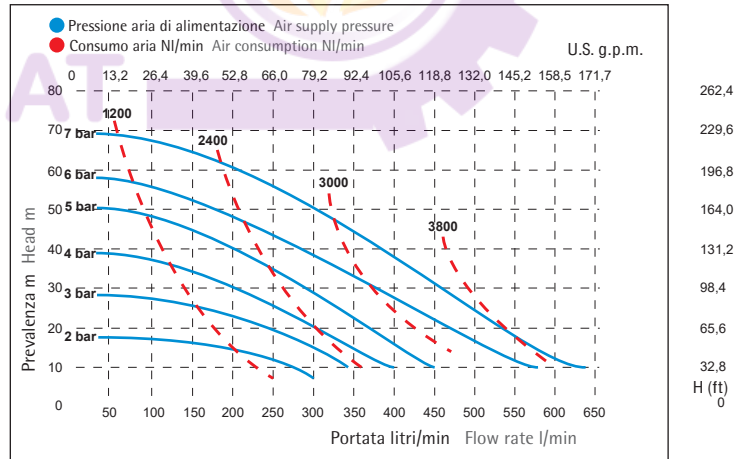

Le curve e le prestazioni sono riferite a pompe con aspirazione immersa e bocca di mandata libera, con acqua a 20°C e variano in funzione dei materiali di composizione

The curves and performance values refer to pumps with submerged suction and a free delivery outlet with water at 20°C, and vary according to the construction material.

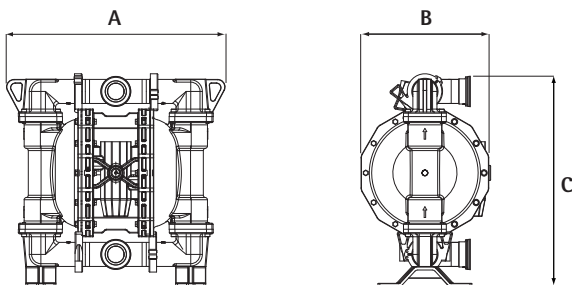

SS316 elettrolucidato	
A (mm)	582
B (mm)	345
C (mm)	570
PESO WEIGHT (Kg)	60
TEMP. MAX MAX TEMP.	95°C

Connessioni filettate ISO-ANSI disponibili su richiesta
ISO-ANSI threaded connections available upon request

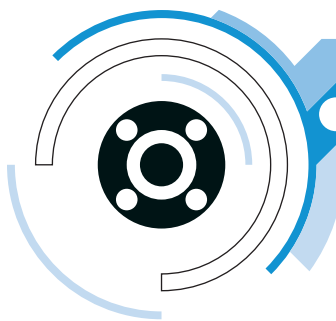

INDUSTRIAL DIVISION

GEMINI CONTROL SERIES

آتور صنعت
ATOORSANAT



CIRCUITO DI CONTROLLO PROPORZIONALE PER POMPE SERIE GEMINI
FUNZIONAMENTO COSTANTE, FREQUENZA (1:n N:1), 4/20MA INGRESSO, SONDA DI LIVELLO

CONTROL CIRCUIT FOR GEMINI SERIES PUMPS
CONSTANT WORKING, FREQUENCY (1:n N:1), 4/20MA INPUT, LEVEL PROBE



adatto a Gemini
dalla P7 alla P700

Suitable for gemini
from P7 to P700

Gemini Control

- Alimentazione 24 vdc
- Display retroilluminato 16 x 20 mm
- Pulsantiera con 4 pulsanti
- Ingresso 4-20ma
- Ingresso segnale reed Ingress sensore effetto Hall
- Ingresso sonda di livello
- Uscita per elettrovalvola
- Protezione da cortocircuito

Solenoid valve

- Alimentazione 24 vdc
- Connessione tubo aria 6x9
- Pressione di esercizio 2.5-10 bar
- T° - 10° + 60°

Gemini Control

24 vdc power supply
Backlight display 16 x 20 mm
Four buttons key pads
4-20ma input
Dry contact water meter input
Electronic water meter input (hall sensor)
Level alarm
Solenoid valve output
Overcurrent protection

Solenoid valve

24 vdc power supply
6x9 tube connection
2.5-10 bar operating air pressure
T° - 10° + 60°

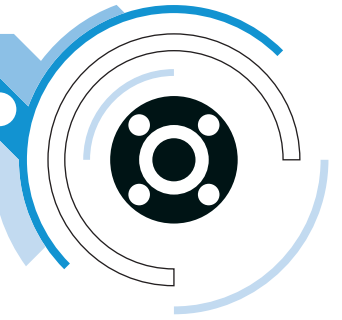

CARATTERISTICHE GENERALI GENERAL FEATURES



DIS.E1

• SOLUZIONE COMPATTA CON TUTTE LE COMPONENTI DI DOSAGGIO PER UN'INSTALLAZIONE PROFESSIONALE

- Da 1 a 3 pompe elettromagnetiche, con o senza sistema brevettato per la regolazione della corsa, per portate fino a 54 l/h e pressioni fino a 20 bar
- Utilizzabili con diversi fluidi, con applicazioni dal trattamento acque all'area industriale, fino all'industria alimentare
- La struttura del sistema di dosaggio include elementi essenziali: punti di calibrazione, valvole di intercettazione, valvole di sicurezza, smorzatori di pulsazioni etc.
- Accessori opzionali: atomizzatori, strumentazioni, connessioni personalizzate, sistemi di riscaldamento

• COMPACT SOLUTION WITH ALL DOSING COMPONENTS FOR A PROFESSIONAL INSTALLATION



DIS.E2

- From 1 to 3 solenoid driven pumps, with or without patented stroke length regulation for flow rates up to 54 l/h and pressures up to 20 bar
- Various working fluids with application from the water treatment to the industrial area, to food industry
- The structure of the dosing systems involves essential elements in the operation: calibration pots, shut off valves, safety valves, pulsation dampers, instrumentation etc
- Optional accessories: atomizers, instrumentation, custom connections, heating systems etc



INDUSTRIAL DIVISION

DI.S SERIES

STAZIONE INTEGRATA DI DOSAGGIO
INTEGRATED DOSING STATION



DIS.M1

• SOLUZIONE COMPATTA CON TUTTE LE COMPONENTI DI DOSAGGIO PER UN'INSTALLAZIONE PROFESSIONALE

- Da 1 a 3 pompe a motore, a pistone o membrana meccanica, con ritorno assistito brevettato, per portate fino a 2000 l/h e pressioni fino a 20 Bar
- Utilizzabili con diversi fluidi, con applicazioni dal trattamento acque all'area industriale, fino all'industria alimentare
- La struttura del sistema di dosaggio include elementi essenziali: punti di calibrazione, valvole di intercettazione, valvole di sicurezza, smorzatori di pulsazioni etc.
- Accessori opzionali: atomizzatori, strumentazioni, connessioni personalizzate, sistemi di riscaldamento

• COMPACT SOLUTION WITH ALL DOSING COMPONENTS FOR A PROFESSIONAL INSTALLATION

- From 1 to 3 motor driven pumps plunger, or mechanical membrane type with patented assisted return, for flow rates up to 2000 l/h and pressures up to 20 bar
- Various working fluids with application from the water treatment to the industrial area, to food industry
- The structure of the dosing systems involves essential elements in the operation: calibration pots, shut off valves, safety valves, pulsation dampers, instrumentation etc
- Optional accessories: atomizers, instrumentation, custom connections, heating systems etc



DIS.M2

CAMPI DI APPLICAZIONE

- Trattamento acque (comuni, trattamento acque reflue)
- Settori industriali (acciaio, ceramica, alimentare, detersivi, cartaria, tessile e farmaceutica)
- Energia (caldaie, desalinatori, torri di raffreddamento, ambiente)

APPLICATION AREAS

- Water treatment (municipalities, wastewater)
- Industrial sectors (steel, ceramics, food & beverages, detergents, paper, textile and pharmaceutical industries)
- Energy (boilers, desalination, cooling towers, environment)

Altri modelli disponibili:

DIS.E3 PLUS: Sistema a 3 pompe elettromagnetiche

DIS.M3 PLUS: Sistema a 3 pompe a motore

Other available models:

DIS.E3 PLUS: 3 electromagnetic pumps system

DIS.M3 PLUS: 3 motor driven pumps system



POMPA A SINGOLA MEMBRANA IDRAULICA CON RITORNO IMPEGNATO
HYDRAULIC SINGLE DIAPHRAGM METERING PUMP

CARATTERISTICHE GENERALI - GENERAL FEATURES



• LA SOLUZIONE IDEALE PER LE APPLICAZIONI CHE RICHIEDONO ELEVATA SICUREZZA OPERATIVA ED AFFIDABILITÀ

• La possibilità di Esecuzione con Materiali diversi consente di offrire una Gamma di Pompe Dosatrici tale da coprire ogni Applicazione di Dosaggio e Miscelazione di Liquidi. Inoltre la completa aderenza alle **normative ATEX** permette l'installazione di queste macchine anche in aree classificate a rischio di esplosione

• **APPLICATIONS** Trattamento delle Acque e Settori Industriali

• Acquedotti, Acque Reflue, Chimico, Alimenti & Bevande, Detergenza, Produzione Energia, Ambiente, Petrochimico, Farmaceutico, Cartario, Tessile

• THE IDEAL SOLUTION FOR APPLICATIONS REQUIRING HIGH LEVELS OF OPERATIONAL SAFETY AND RELIABILITY

• Their possibility of construction with various materials allows these metering pumps to satisfy every liquid dosing and mixing application. Furthermore, their complete compliance with the **ATEX Standards** even allows for these pumps to be installed in hazardous areas

• **APPLICATIONS** Water Treatment and Industrial Sector

• Municipalities, Wastewater, Chemical, Food & Beverages, Detergent, Power Generation, Environment, Petrochemical, Pharmaceutical, Paper, Textile

MECCANISMO - MECHANISM



• LA SOLUZIONE IDEALE PER LE APPLICAZIONI CHE RICHIEDONO ALTI LIVELLI DI SICUREZZA OPERATIVA E AFFIDABILITÀ

• Zero perdite; costruzione ermetica per il dosaggio di sostanze tossiche, corrosive e altri liquidi pericolosi, per i quali l'assenza di perdite è fondamentale

• Protezione contro gli inquinanti esterni che possano contaminare il liquido che viene pompato

• Flessibilità d'uso; il diaframma in PTFE è compatibile con una vasta gamma di liquidi

• **SISTEMA DI RIEMPIMENTO MECCANICO**

• Mantiene un livello costante del fluido, garantendo quindi la massima precisione e la ripetibilità. Tiene inoltre sotto controllo la deformazione del diaframma, prolungandone quindi la durata.

• THE IDEAL SOLUTION FOR APPLICATIONS REQUIRING HIGH LEVELS OF OPERATIONAL SAFETY AND RELIABILITY

• Zero leakage; hermetic construction for dosing toxic, corrosive and other unsafe liquids, for which the absence of leakage is fundamental

• Protection against external pollutants which could contaminate the liquid being pumped

• Flexibility of use; the PTFE diaphragm is compatible with a huge liquid range

• **MECHANICAL REFILLING SYSTEM**

• It maintains an hydraulic fluid constant level, thereby guaranteeing maximum precision and repeatability. It also keeps under control the deformation of the diaphragm thereby increasing its duration

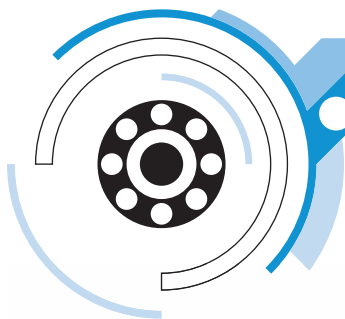

CARATTERISTICHE TECNICHE TECHNICAL FEATURES

VENTING SYSTEM



Oltre a garantire la ventilazione automatica durante il funzionamento, il sistema di ventilazione facilita l' innesco della pompa favorendo lo spurgo dell'aria mediante un'azione manuale

Aside from guaranteeing automatic venting during operation, the venting system also facilitates the pump priming by favouring the air purge by means of a manual action

CARTRIDGE VALVES



Al fine di assicurare la massima precisione nel dosaggio, anche per piccoli flussi, sono disponibili configurazioni a 2 o 3 sfere con alloggiamenti di alta precisione. Le guarnizioni metalliche per le teste in acciaio inossidabile AISI 316L e quelle in FPM per quelle in plastica, garantiscono la massima compatibilità

In order to ensure maximum dosing precision, even for small flow rates, double and triple ball configurations are available with high precision seats. The metal gaskets for the AISI 316L stainless steel heads, and the FPM gaskets for those in plastic, guarantee maximum compatibility

PRESSURE RELIEF VALVE



Protegge la pompa da sovraccarichi di pressione inaspettati

It protects the pump against unexpected overpressures

FLOW RATE ADJUSTMENT



Una manopola facile da maneggiare e con un indicatore ad alta visibilità per la migliore regolazione del dosaggio

Easy to handle knob with high visibility nonius for the best flow adjustment

PORTATA FLOW RATE	PRESSIONE PRESSURE	TEMPERATURA TEMPERATURE	MATERIALI A CONTATTO CONTACT MATERIALS
fino a up to 660 l/h con testata singola with a single head	fino a up to 124 bar	ambient -5÷40°C fluid -5÷50°C	AISI 316L; PP; PVDF; PVC



INDUSTRIAL DIVISION POWERSERIES

POMPA A DOPPIA MEMBRANA IDRAULICA CON RITORNO IMPEGNATO
HYDRAULIC DOUBLE DIAPHRAGM METERING PUMP



CARATTERISTICHE GENERALI - GENERAL FEATURES

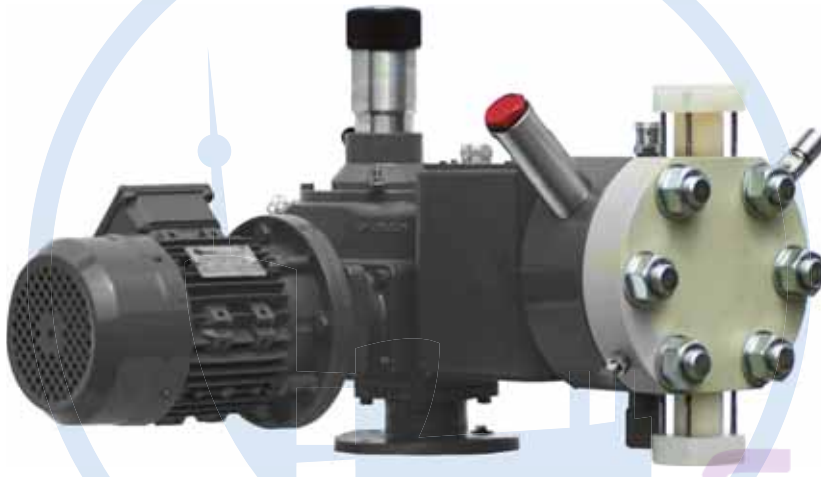

● LA SOLUZIONE IDEALE PER LE APPLICAZIONI CHE RICHIEDONO ELEVATA SICUREZZA OPERATIVA ED AFFIDABILITÀ

● La possibilità di Esecuzione con Materiali diversi consente di offrire una Gamma di Pompe Dosatrici tale da coprire ogni Applicazione di Dosaggio e Miscelazione di Liquidi. Inoltre la completa aderenza alle **normative ATEX** permette l'installazione di queste macchine anche in aree classificate a rischio di esplosione

● APPLICATIONS Trattamento delle Acque e Settori Industriali

● Acquedotti, Acque Reflue, Chimico, Alimenti & Bevande, Detergenza, Produzione Energia, Ambiente, Petrochimico, Farmaceutico, Cartario, Tessile

● THE IDEAL SOLUTION FOR APPLICATIONS REQUIRING HIGH LEVELS OF OPERATIONAL SAFETY AND RELIABILITY

● Their possibility of construction with various materials allows these metering pumps to satisfy every liquid dosing and mixing application. Furthermore, their complete compliance with the **ATEX Standards** even allows for these pumps to be installed in hazardous areas

● APPLICATIONS Water Treatment and Industrial Sector

● Municipalities, Wastewater, Chemical, Food & Beverages, Detergent, Power Generation, Environment, Petrochemical, Pharmaceutical, Paper, Textile

PORTATA FLOW RATE	PRESSIONE PRESSURE	TEMPERATURA TEMPERATURE	MATERIALI A CONTATTO CONTACT MATERIALS
fino a up to 2610 l/h con testata singola with a single head	fino a up to 200 bar	ambient -5÷40°C fluid -5÷50°C	AISI 316L; PP; PVDF;

MECCANISMO - MECHANISM

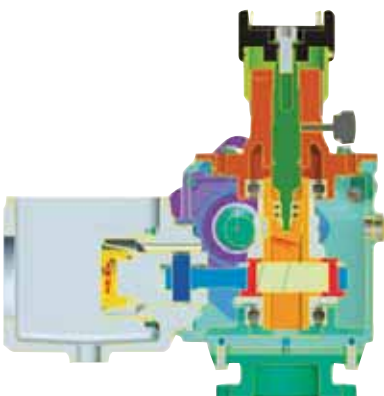

Meccanismo

Ritorno meccanico disponibile in varie dimensioni

Caratteristiche Principali

- Trasmissione a vite interna, lubrificata in bagno d'olio per una riduzione delle emissioni di rumore
- Parti rotanti su cuscinetti per ridurre il consumo di energia
- Ogni meccanismo arriva completo di una trasmissione interna; pompe a diversa velocità (colpi al minuto) possono quindi essere connesse, consentendo una maggiore flessibilità nella scelta autonoma delle pompe
- Regolazione ad alta precisione del colpo, sia manuale sia attraverso un attuatore elettrico o pneumatico o convertitore di frequenza
- Grado di accuratezza $\pm 1\%$

Mechanism

Mechanical return type available in various sizes

Main Features

- Internal worm gearbox, oil bath lubricated with low noise emission
- Rotating parts on bearing to minimize power consumption
- Each mechanism comes complete with an internal gearbox; pumps with different speed (strokes/min) can therefore be joined, allowing for greater flexibility in selecting the pumps themselves
- High precision stroke adjustment, both manual and by means of an electric or pneumatic actuator or frequency converter
- Accuracy within $\pm 1\%$

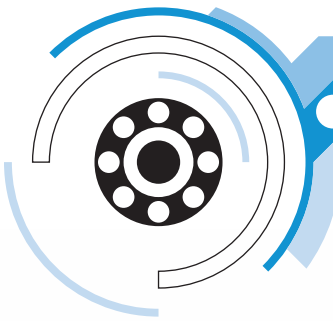

CARATTERISTICHE TECNICHE / TECHNICAL FEATURES

VENTING SYSTEM



Oltre a garantire la ventilazione automatica durante il funzionamento, il sistema di ventilazione facilita l'innescio della pompa favorendo lo spurgo dell'aria mediante un'azione manuale

Aside from guaranteeing automatic venting during operation, the venting system also facilitates the pump priming by favouring the air purge by means of a manual action

CARTRIDGE VALVES



Al fine di assicurare la massima precisione nel dosaggio, anche per piccoli flussi, sono disponibili configurazioni a 2 o 3 sfere con alloggiamenti di alta precisione. Le guarnizioni metalliche per le teste in acciaio inossidabile AISI 316L e quelle in FPM per quelle in plastica, garantiscono la massima compatibilità

In order to ensure maximum dosing precision, even for small flow rates, double and triple ball configurations are available with high precision seats. The metal gaskets for the AISI 316L stainless steel heads, and the FPM gaskets for those in plastic, guarantee maximum compatibility

PRESSURE RELIEF VALVE



Protegge la pompa da sovraccarichi di pressione inaspettati

It protects the pump against unexpected overpressures

FLOW RATE ADJUSTMENT



Una manopola facile da maneggiare e con un indicatore ad alta visibilità per la migliore regolazione del dosaggio

Easy to handle knob with high visibility nonius for the best flow adjustment

- Zero perdite; costruzione ermetica per il dosaggio di sostanze tossiche, corrosive e altri liquidi pericolosi, per i quali l'assenza di perdite è fondamentale
- Protezione contro gli inquinanti esterni che possano contaminare il liquido che viene pompato
- Doppio diaframma, doppia protezione; se uno dei due diaframmi si danneggia, il sistema segnala immediatamente l'anomalia e alla pompa viene tuttavia permesso di operare
- Flessibilità d'uso; i diaframmi in PTFE sono compatibili con una grande varietà di liquidi
- Modularità del flusso; il flusso può essere variato semplicemente sostituendo il pistone e la cartuccia di sigillo
- Il posizionamento del diaframma è assicurato da una sistema meccanico che non richiede la presenza di filtri perforati; questo consente l'utilizzo di liquidi con solidi in sospensione
- Materiali di costruzione; le parti della configurazione standard in contatto con il liquido sono di acciaio inossidabile AISI 316L, PP o PVDF. Altri materiali disponibili su richiesta

- Zero leakage; hermetic construction for dosing toxic, corrosive and other unsafe liquids, for which the absence of leakage is fundamental
- Protection against external pollutants which could contaminate the liquid being pumped
- Double diaphragm, double protection; if one of the two diaphragm is damaged, the system immediately reveals the anomaly; the pump is nevertheless permitted to continue operating, thereby preventin the immediate downtime.
- Flexibility of use; the PTFE diaphragms are compatible with most liquids
- Flow rate modularity; the rated flow-rate can be changed simply replacing the plunger and the relevant seal cartridge
- Solid suspension; the diaphragm's proper positioning is ensured by a mechanical system which does not require the use of perforated shields on the process side thereby allowing for liquids containing solid suspensions to be pumped
- Construction Materials; the parts in the standard configuration that make contact with the liquid are all made of AISI 316L stainless steel, PP and PVDF. Other materials available on request



INDUSTRIAL DIVISION POWER SERIES

POMPA A DOPPIA MEMBRANA IDRAULICA CON RITORNO IMPEGNATO HYDRAULIC DOUBLE DIAPHRAGM METERING PUMP

CARATTERISTICHE GENERALI - GENERAL FEATURES



● LA SOLUZIONE IDEALE PER LE APPLICAZIONI CHE RICHIEDONO ELEVATA SICUREZZA OPERATIVA ED AFFIDABILITÀ

● La possibilità di Esecuzione con Materiali diversi consente di offrire una Gamma di Pompe Dosatrici tale da coprire ogni Applicazione di Dosaggio e Miscelazione di Liquidi. Inoltre la completa aderenza alle **normative ATEX** permette l'installazione di queste macchine anche in aree classificate a rischio di esplosione

● APPLICATIONS Trattamento delle Acque e Settori Industriali

● Acquedotti, Acque Reflue, Chimico, Alimenti & Bevande, Detergenza, Produzione Energia, Ambiente, Petrochimico, Farmaceutico, Cartario, Tessile

● THE IDEAL SOLUTION FOR APPLICATIONS REQUIRING HIGH LEVELS OF OPERATIONAL SAFETY AND RELIABILITY

● Their possibility of construction with various materials allows these metering pumps to satisfy every liquid dosing and mixing application. Furthermore, their complete compliance with the **ATEX Standards** even allows for these pumps to be installed in hazardous areas

● APPLICATIONS Water Treatment and Industrial Sector

● Municipalities, Wastewater, Chemical, Food & Beverages, Detergent, Power Generation, Environment, Petrochemical, Pharmaceutical, Paper, Textile

PORTATA FLOW RATE	PRESSIONE PRESSURE	TEMPERATURA TEMPERATURE	MATERIALI A CONTATTO CONTACT MATERIALS
fino a up to 2610 l/h con testata singola with a single head	fino a up to 200 bar	ambient -5÷40°C fluid -5÷50°C	AISI 316L; PP; PVDF;

MECCANISMO - MECHANISM

Meccanismo

Ritorno meccanico disponibile in varie dimensioni

Caratteristiche Principali

- Trasmissione a vite interna, lubrificata in bagno d'olio per una riduzione delle emissioni di rumore
- Parti rotanti su cuscinetti per ridurre il consumo di energia
- Ogni meccanismo arriva completo di una trasmissione interna; pompe a diversa velocità (colpi al minuto) possono quindi essere connesse, consentendo una maggiore flessibilità nella scelta autonoma delle pompe
- Regolazione ad alta precisione del colpo, sia manuale sia attraverso un attuatore elettrico o pneumatico o convertitore di frequenza
- Grado di accuratezza $\pm 1\%$

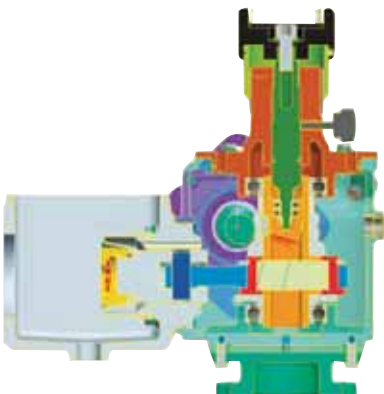

Mechanism

Mechanical return type available in various sizes

Main Features

- Internal worm gearbox, oil bath lubricated with low noise emission
- Rotating parts on bearing to minimize power consumption
- Each mechanism comes complete with an internal gearbox; pumps with different speed (strokes/min) can therefore be joined, allowing for greater flexibility in selecting the pumps themselves
- High precision stroke adjustment, both manual and by means of an electric or pneumatic actuator or frequency converter
- Accuracy within $\pm 1\%$

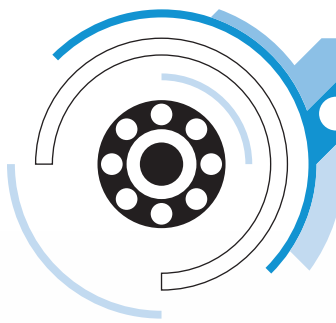

CARATTERISTICHE TECNICHE / TECHNICAL FEATURES

VENTING SYSTEM



Oltre a garantire la ventilazione automatica durante il funzionamento, il sistema di ventilazione facilita l'innescio della pompa favorendo lo spurgo dell'aria mediante un'azione manuale

Aside from guaranteeing automatic venting during operation, the venting system also facilitates the pump priming by favouring the air purge by means of a manual action

CARTRIDGE VALVES



Al fine di assicurare la massima precisione nel dosaggio, anche per piccoli flussi, sono disponibili configurazioni a 2 o 3 sfere con alloggiamenti di alta precisione. Le guarnizioni metalliche per le teste in acciaio inossidabile AISI 316L e quelle in FPM per quelle in plastica, garantiscono la massima compatibilità

In order to ensure maximum dosing precision, even for small flow rates, double and triple ball configurations are available with high precision seats. The metal gaskets for the AISI 316L stainless steel heads, and the FPM gaskets for those in plastic, guarantee maximum compatibility

PRESSURE RELIEF VALVE



Protegge la pompa da sovraccarichi di pressione inaspettati

It protects the pump against unexpected overpressures

FLOW RATE ADJUSTMENT



Una manopola facile da maneggiare e con un indicatore ad alta visibilità per la migliore regolazione del dosaggio

Easy to handle knob with high visibility nonius for the best flow adjustment

- Zero perdite; costruzione ermetica per il dosaggio di sostanze tossiche, corrosive e altri liquidi pericolosi, per i quali l'assenza di perdite è fondamentale
- Protezione contro gli inquinanti esterni che possano contaminare il liquido che viene pompato
- Doppio diaframma, doppia protezione; se uno dei due diaframmi si danneggia, il sistema segnala immediatamente l'anomalia e alla pompa viene tuttavia permesso di operare
- Flessibilità d'uso; i diaframmi in PTFE sono compatibili con una grande varietà di liquidi
- Modularità del flusso; il flusso può essere variato semplicemente sostituendo il pistone e la cartuccia di sigillo
- Il posizionamento del diaframma è assicurato da un sistema meccanico che non richiede la presenza di filtri perforati; questo consente l'utilizzo di liquidi con solidi in sospensione
- Materiali di costruzione; le parti della configurazione standard in contatto con il liquido sono di acciaio inossidabile AISI 316L, PP o PVDF. Altri materiali disponibili su richiesta

- Zero leakage; hermetic construction for dosing toxic, corrosive and other unsafe liquids, for which the absence of leakage is fundamental
- Protection against external pollutants which could contaminate the liquid being pumped
- Double diaphragm, double protection; if one of the two diaphragms is damaged, the system immediately reveals the anomaly; the pump is nevertheless permitted to continue operating, thereby preventing the immediate downtime.
- Flexibility of use; the PTFE diaphragms are compatible with most liquids
- Flow rate modularity; the rated flow-rate can be changed simply replacing the plunger and the relevant seal cartridge
- Solid suspension; the diaphragm's proper positioning is ensured by a mechanical system which does not require the use of perforated shields on the process side thereby allowing for liquids containing solid suspensions to be pumped
- Construction Materials; the parts in the standard configuration that make contact with the liquid are all made of AISI 316L stainless steel, PP and PVDF. Other materials available on request



INJECTA
the perfect dosing

via F.M. Malfatti, 49 - 02100 Vazia (RIETI), ITALY
tel. +39 0746 221438 r.a.
fax. +39 0746 229070
e-mail info@injecta.com

www.injecta.com

آتور صنعت

ATOORSANAT

