



Circulators Pumps _ UPR | UPRF | UPRFE

Made in Europe

آتور صنعت

اعتبار دگار



Catalogo 50/60 Hz

CIRCULATING FOR HEATING AND CONDITIONING

Central heating circulation pumps

UPR 40 - UPR 60 - UPR 80

Technical data

- single-phase motor with a wet rotor
- three rotational speeds
- operating voltage: 1 x 230 V~50 Hz
- max. operating pressure: 10 bar
- media temperature: 5°C to 110°C max.
- ambient temperature: 40°C max.
- protection type: IP 44
- connection: external thread GZ 1", 1 1/4", 1 1/2" (standard), 2"
- length: 180 mm (standard), 130 mm, 110 mm (brass)



The pump has been created to pump warm water in central heating systems, however it can be used to pump liquid media in industrial and commercial usage. The pump may also be a part of a solar heating installation.

The articles are manufactured from the highest quality cast iron and chrome-nickel steel, which guarantees that the products are of high quality. The product has a ceramic bearing ring and a rotor disk made of technical polymer.

Pumps' characteristics

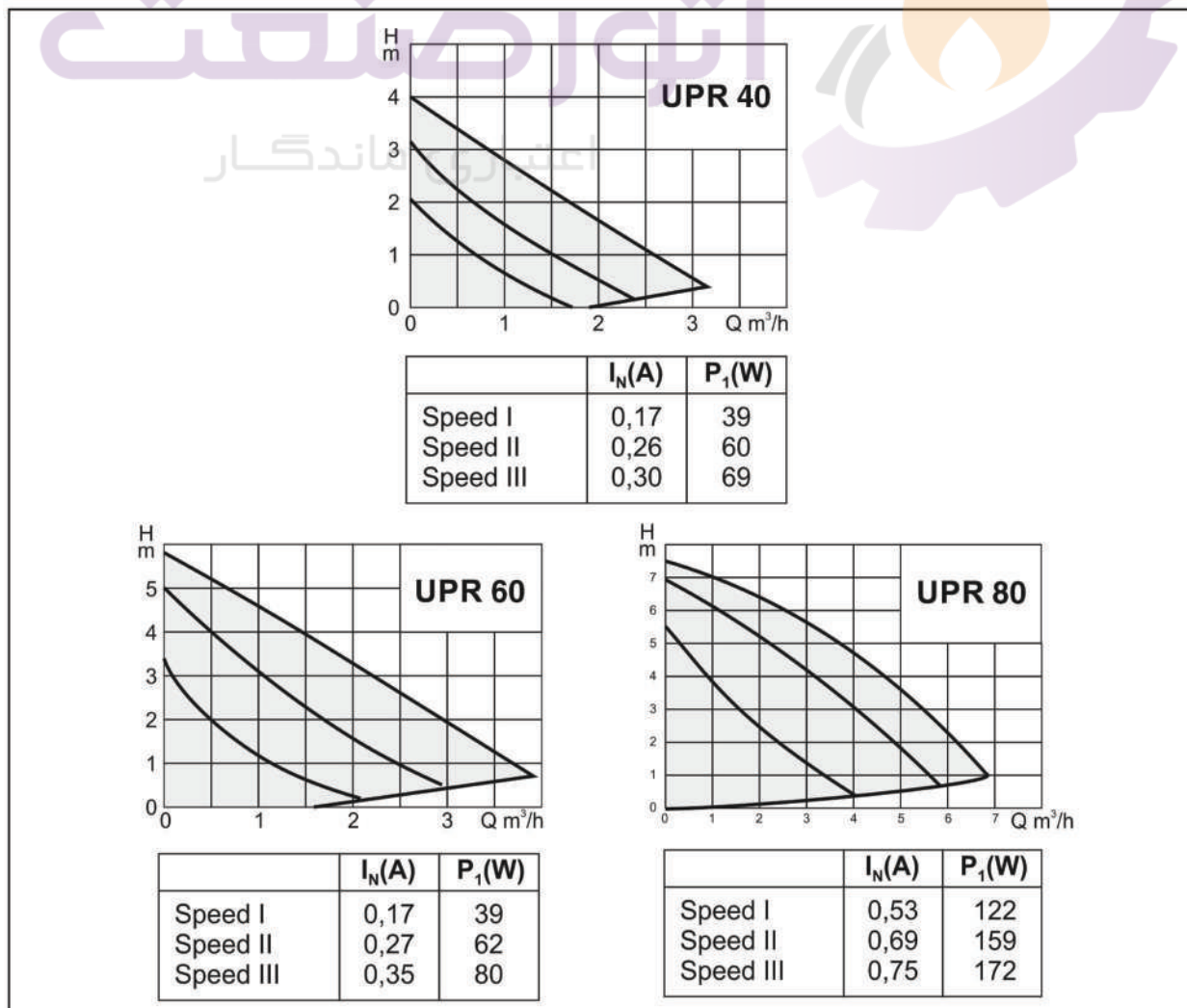



Dimension illustration

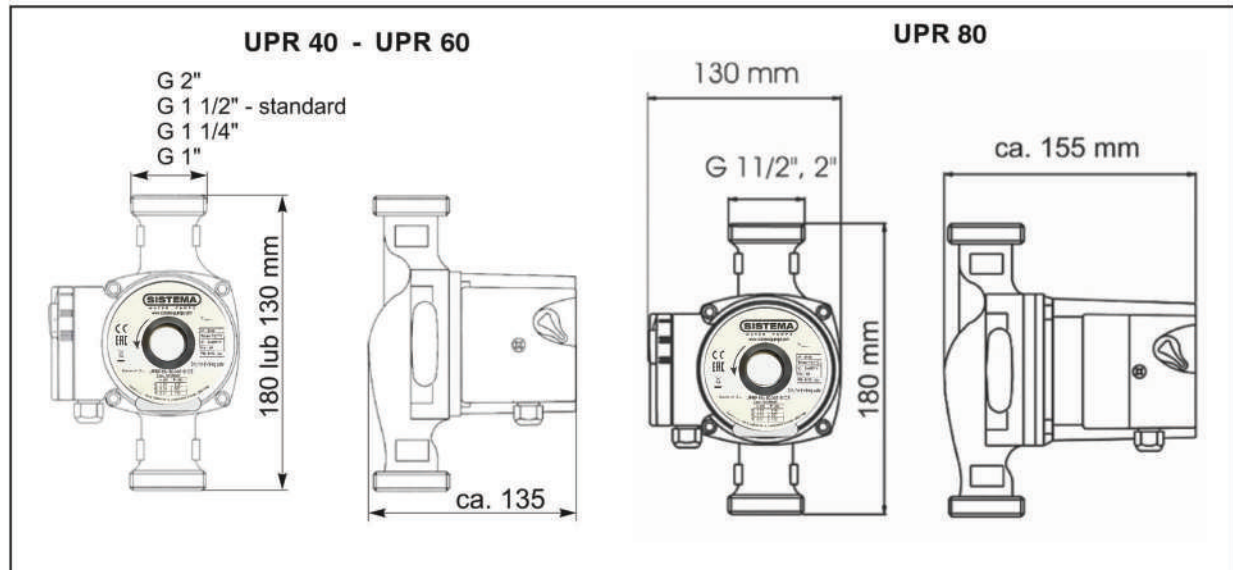

UPR 40

Article	Pump body	Length (mm)	DN	External thread	H(m)	Power consumption (W)
UPR 15/40-130	Cast iron	130	15	G 1"	4	28-63
UPR 20/40-130	Cast iron	130	20	G 1 1/4"	4	28-63
UPR 25/40-130	Cast iron	130	25	G 1 1/2"	4	28-63
UPR 20/40-180	Cast iron	180	20	G 1 1/4"	4	28-63
UPR 25/40-180	Cast iron	180	25	G 1 1/2"	4	28-63
UPR 32/40-180	Cast iron	180	32	G 2"	4	28-63

UPR 60

Article	Pump body	Length (mm)	DN	External thread	H(m)	Power consumption (W)
UPR 15/60-130	Cast iron	130	15	G 1"	6	39-80
UPR 20/60-130	Cast iron	130	20	G 1 1/4"	6	39-80
UPR 25/60-130	Cast iron	130	25	G 1 1/2"	6	39-80
UPR 20/60-180	Cast iron	180	20	G 1 1/4"	6	39-80
UPR 25/60-180	Cast iron	180	25	G 1 1/2"	6	39-80
UPR 32/60-180	Cast iron	180	32	G 2"	6	39-80

UPR 80

Article	Pump body	Length (mm)	DN	External thread	H(m)	Power consumption (W)
UPR 25/80-130	Cast iron	130	25	G 1 1/2"	8	122-170
UPR 32/80-130	Cast iron	130	32	G 2"	8	122-170
UPR 25/80-180	Cast iron	180	25	G 1 1/2"	8	122-170
UPR 32/80-180	Cast iron	180	32	G 2"	8	122-170

THREE SPEEDS THREE PHASE CIRCULATING PUMP

Applications

The SISTEMA UPRF circulators for clean liquids, without abrasives, which are non-aggressive for the pump materials (contents of solids up to 0.2%). For heating, conditioning, cooling and circulation plants. For civil and industrial applications. When low noise operation is required.

Limits of application

- Liquid temperature from -10 °C to +120 °C (in short-time duty up to + 140 °C).
- Ambient temperature up to 40 °C.
- Maximum glycol quantity: 50% (Mixture with more than 20% glycol content require rechecking of the pumping data).
- Maximum permissible working pressure 6/10 bar.

Motor

- 2/4 pole induction motor, 50 Hz.
- Three adjustable speeds.
- UPRF: three-phase 400 V.
- Insulation class F.
- Protection IP 43.

Components

- Pump casing Cast iron
- Impeller Stainless steel
- Shaft Stainless steel

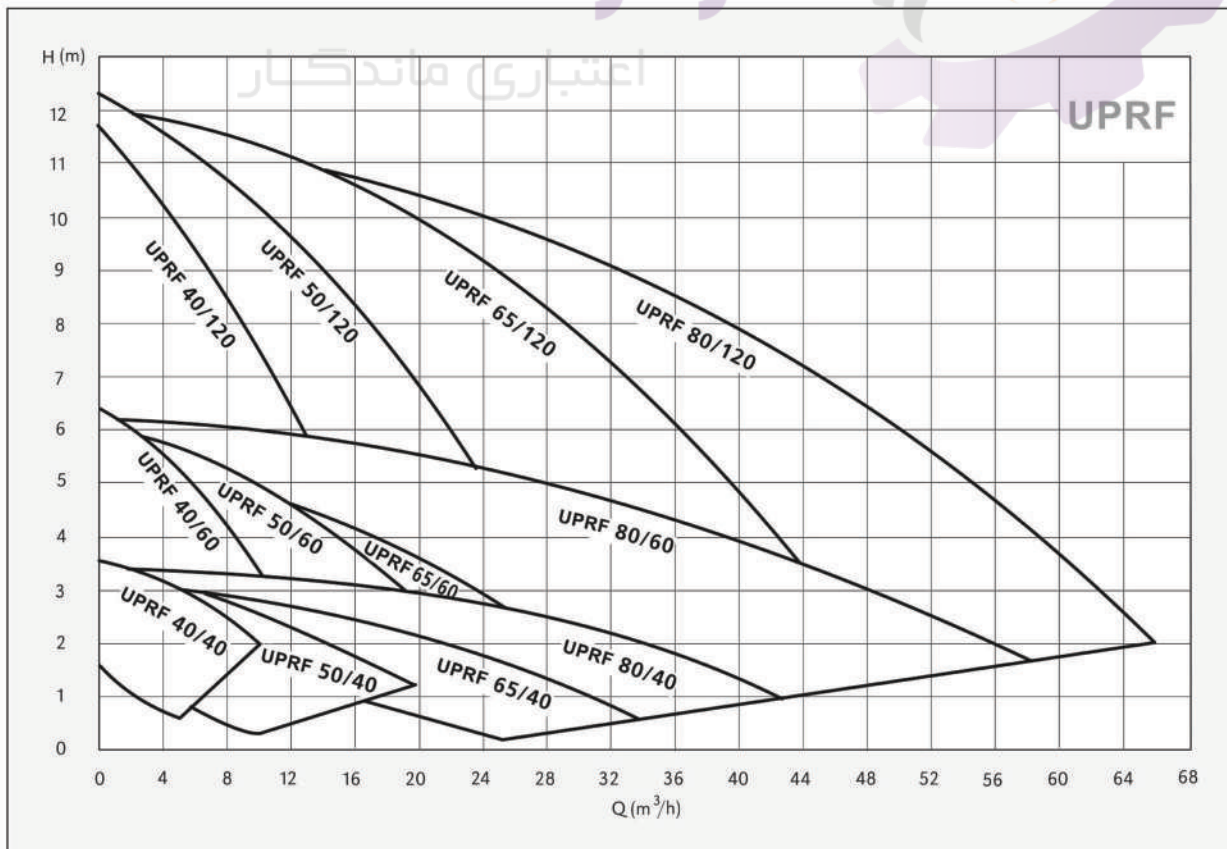

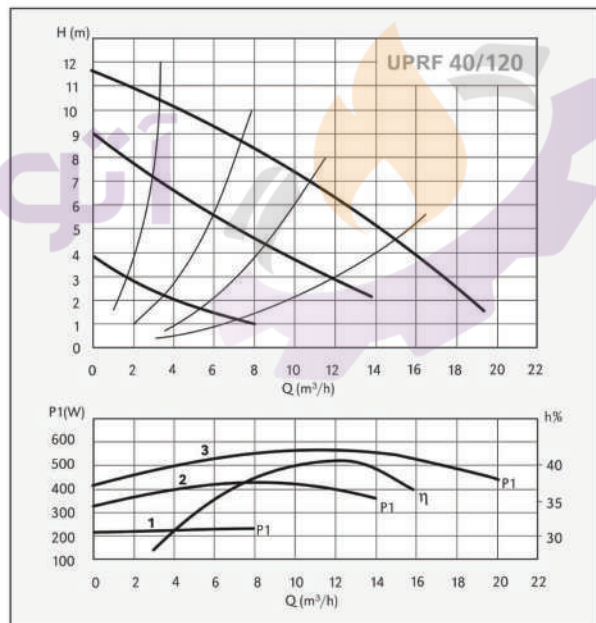
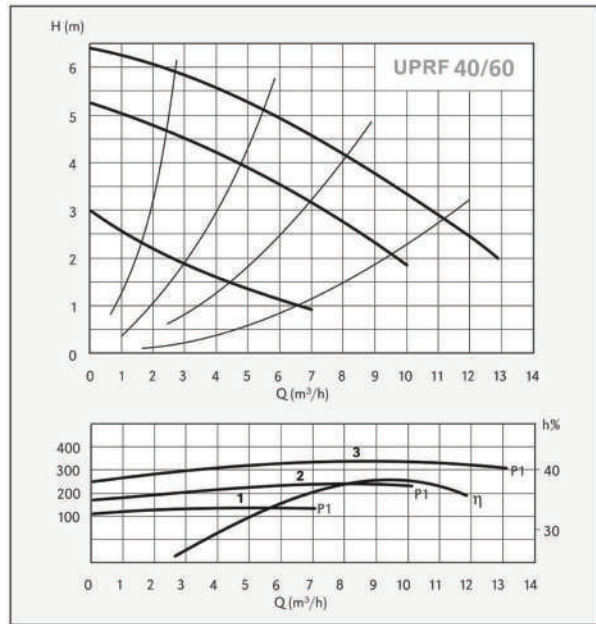
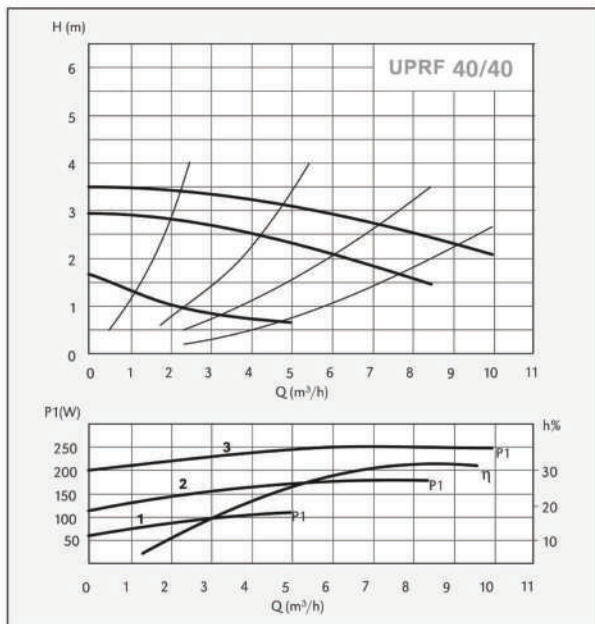

انوار صنعت
اعتباری ماندگار

DIMENSIONS AND WEIGHTS

TYPE	DN	N° Pole		Pos.	1/min	P1 (W)	3x 400 V [A]	[kg]	
		2	4						
UPRF 40-40/250	40	✓		3	1440	240	0,76	17,0	
				2	1200	160	0,24		
				1	660	100	0,11		
UPRF 40-60/250	40	✓		3	2790	320	0,74	17,5	
				2	2240	240	0,36		
				1	1440	140	0,18		
UPRF 40-120/250	40	✓		3	2820	560	1,16	19,0	
				2	2200	400	0,64		
				1	1250	220	0,26		

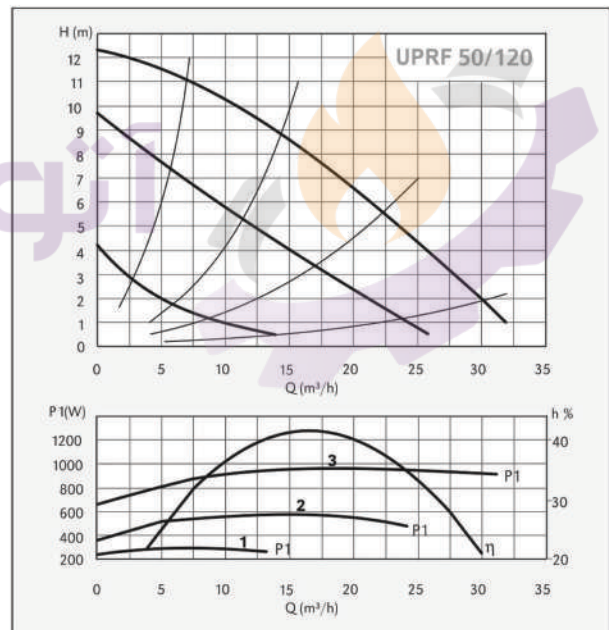
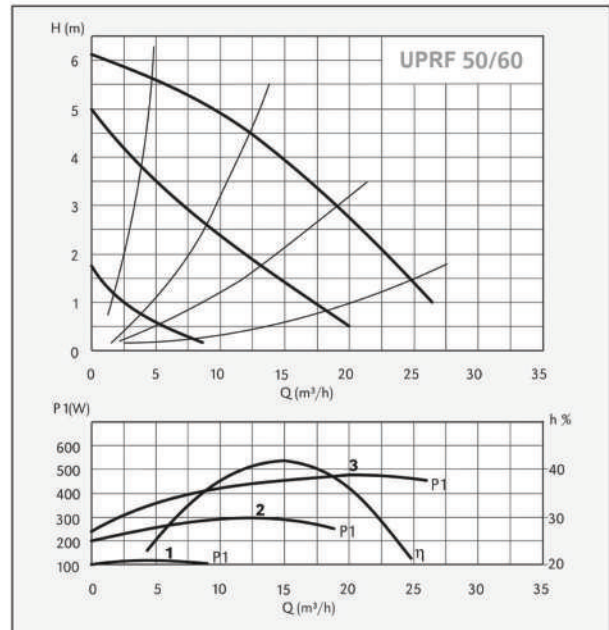
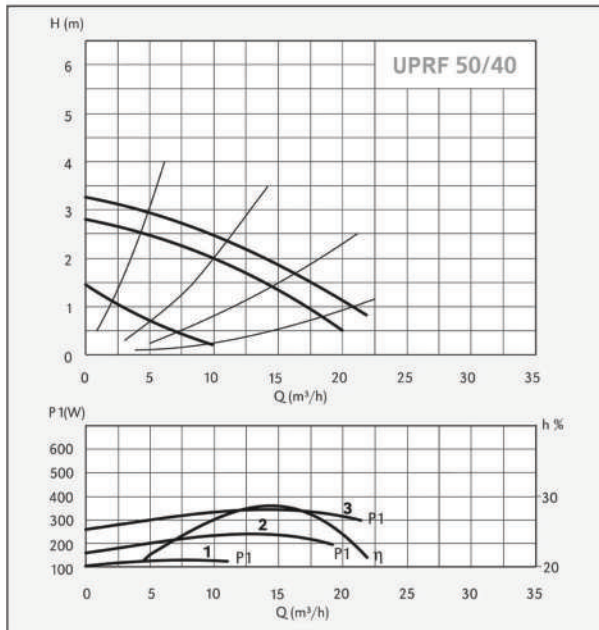

انور صنعت
اعتباری ماندگار

DIMENSIONS AND WEIGHTS

TYPE	DN	N° Pole		Pos.	1/min	P1 (W)	3x 400 V [A]	[kg]	
		2	4						
UPRF 50-40/280	50	✓		3	1450	340	1,05	24,0	
				2	1220	240	0,44		
				1	620	120	0,22		
UPRF 50-60/280	50	✓		3	1400	470	1,15	24,0	
				2	1000	300	0,55		
				1	560	100	0,20		
UPRF 50-120/280	50	✓		3	2800	950	1,73	24,0	
				2	2330	540	1,05		
				1	1270	265	0,46		

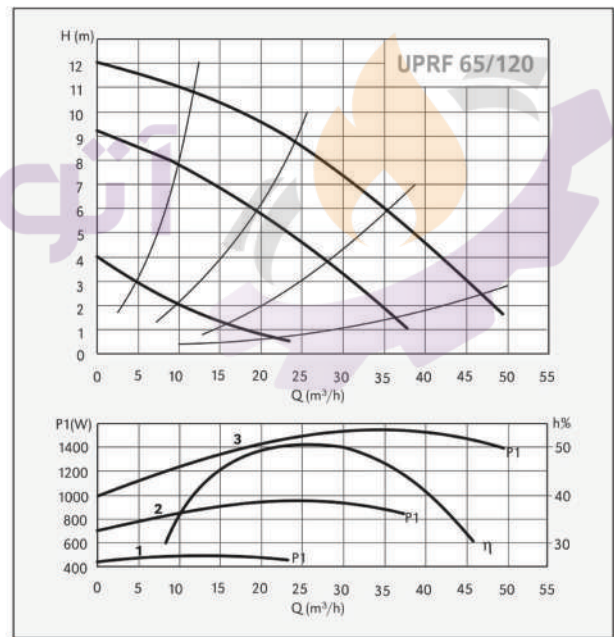
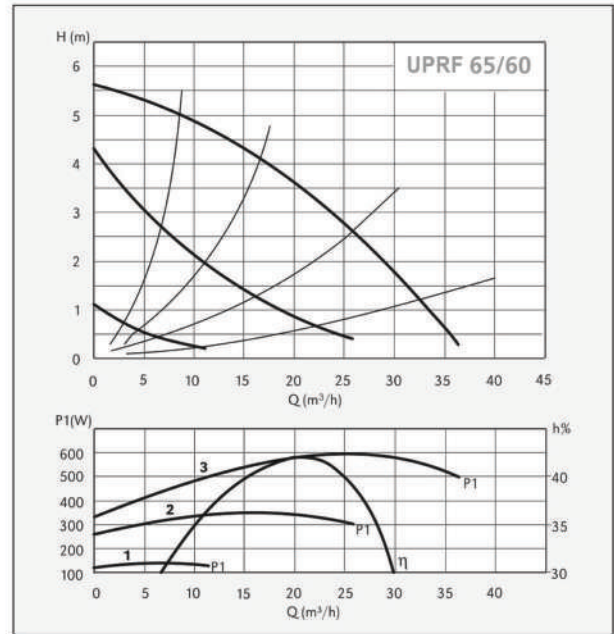
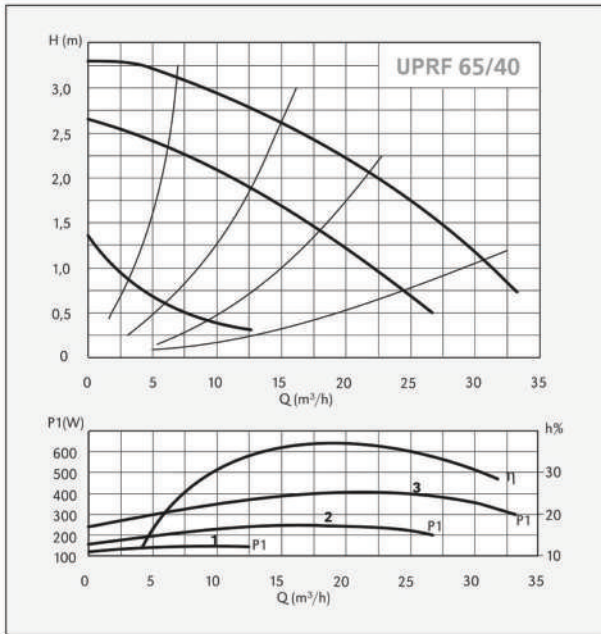

انوار صنعت
اعتباری ماندگار

DIMENSIONS AND WEIGHTS

TYPE	DN	N° Pole		Pos.	1/min	P1 (W)	3x 400 V [A]	[kg]	
		2	4						
UPRF 65-40/340	65	✓		3	1430	400	1,10	29,0	
				2	1150	260	0,50		
				1	600	120	0,22		
UPRF 65-60/340	65	✓		3	1370	600	1,25	29,0	
				2	950	360	0,64		
				1	450	120	0,22		
UPRF 65-120/340	65	✓		3	2810	1560	2,80	31,0	
				2	2200	960	1,70		
				1	1250	460	0,84		

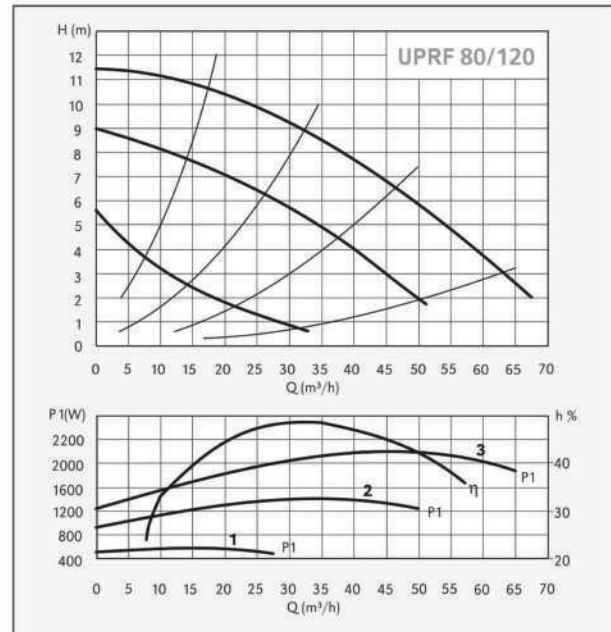
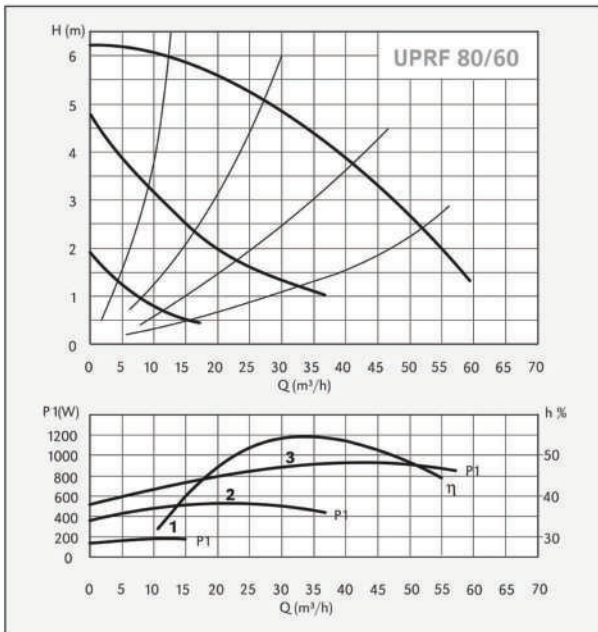

آتور صنعت

اعتباری ماندگار



DIMENSIONS AND WEIGHTS

TYPE	DN	N° Pole		Pos.	1/min	P1 (W)	3x 400 V [A]	[kg]	
		2	4						
UPRF 80-60/360	80	✓		3	1350	690	2,20	33,5	
				2	1000	560	1,10		
				1	600	200	0,38		
UPRF 80-120/360	80	✓		3	2800	2200	3,80	34,5	
				2	2160	1400	2,40		
				1	1200	550	1,05		

THREE-SPEED SINGLE-PHASE CIRCULATION PUMP

Applications

The SISTEMA UPRFE circulators for clean liquids, without abrasives, which are non-aggressive for the pump materials (contents of solids up to 0.2%). For heating, conditioning, cooling and circulation plants. For civil and industrial applications. When low noise operation is required.

Limits of application

- Liquid temperature from -10 °C to +120 °C (in short-time duty up to + 140 °C).
- Ambient temperature up to 40 °C.
- Maximum glycol quantity: 50% (Mixture with more than 20% glycol content require rechecking of the pumping data).
- Maximum permissible working pressure 6/10 bar.

Motor

- 2/4 pole induction motor, 50 Hz.
- Three adjustable speeds.
- UPRFE: single-phase 230 V.
- Insulation class F.
- Protection IP 43.

Components

- Pump casing Cast iron
- Impeller Stainless steel
- Shaft Stainless steel

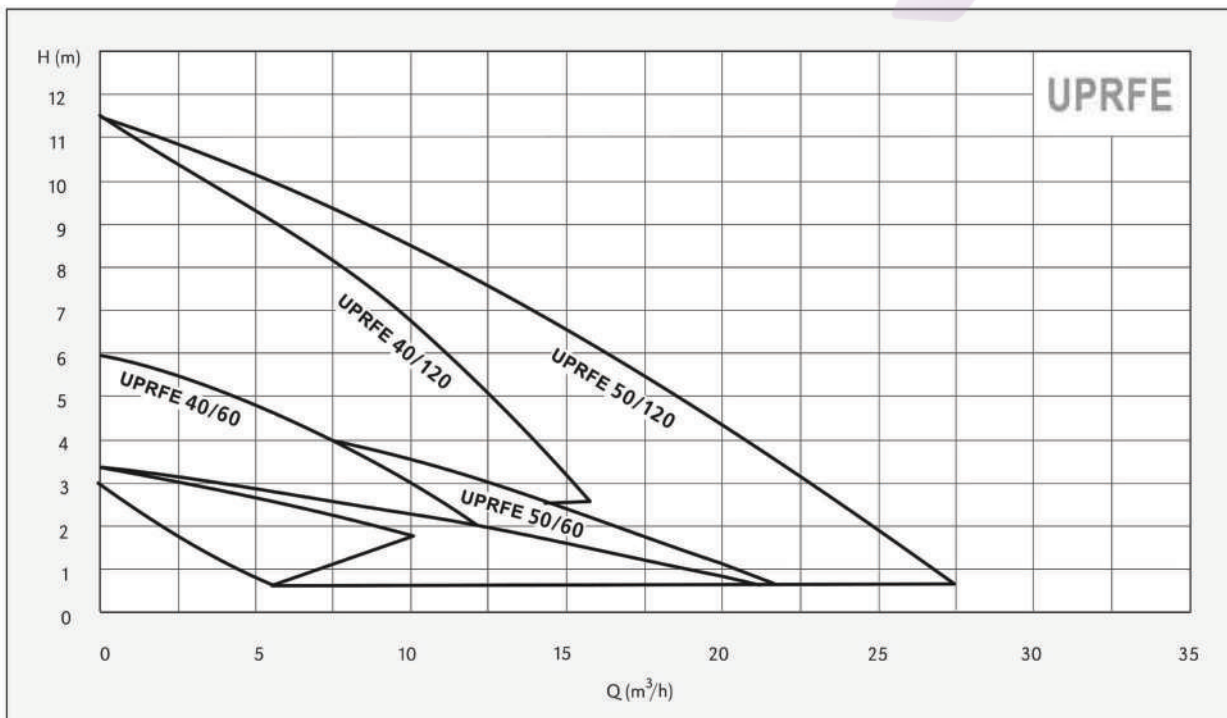

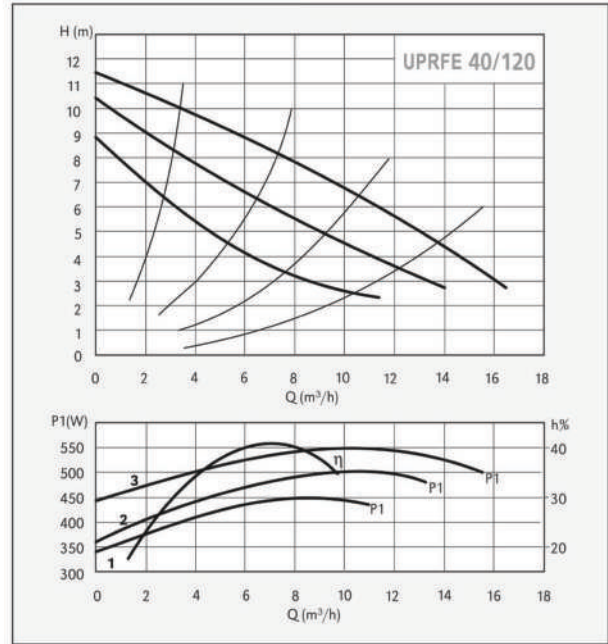
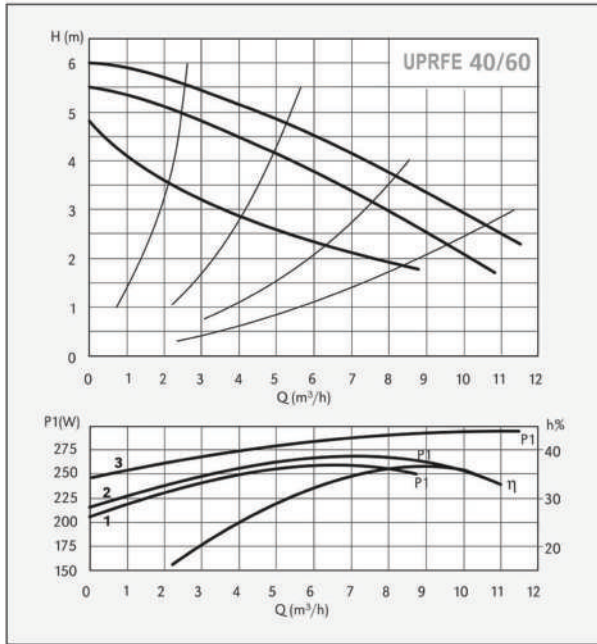

آتور صنعت

اعتباری ماندگار



DIMENSIONS AND WEIGHTS

TYPE	DN	N° Pole		Pos.	1/min	P1 (W)	1x 230V [A]	[kg]		
		2	4							
UPRFE 40-60/250	40	✓		3	2690	285	1,20	17,5		
				2	2360	245	1,18			
				1	1820	225	1,15			
UPRFE 40-120/250	40	✓		3	2750	550	2,35	19,0		
				2	2100	475	2,30			
				1	1270	355	1,85			

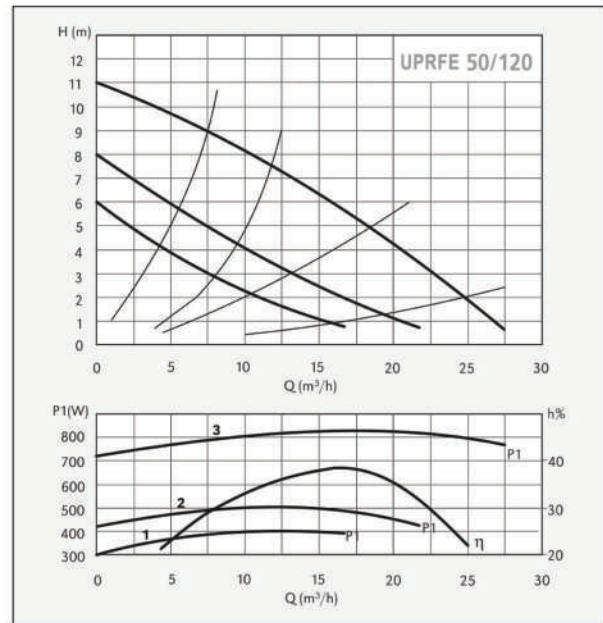
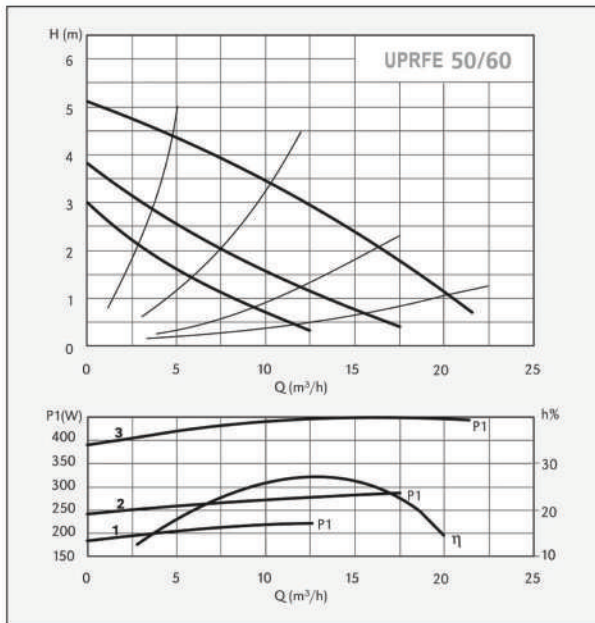

آتور صنعت

اعتباری ماندگار



DIMENSIONS AND WEIGHTS

TYPE	DN	N° Pole		Pos.	1/min	P1 (W)	1x 230V [A]	[kg]	
		2	4						
UPRFE 50-60/280	50	✓		3	1260	415	1,8	24,5	
				2	1030	300	1,3		
				1	740	230	1,0		
UPRFE 50-120/280	50	✓		3	2720	830	3,6	24,5	
				2	1870	480	2,1		
				1	1450	390	1,7		