

ELETTROPOMPE SOMMERSE CON TRITURATORE  
CUTTING SUBMERSIBLE PUMPS



ACCESSORIO  
ACCESSORY

1"½ 150-200-300  
2" 500-750

VEDI SCHEMA  
SEE SCHEME pag. 222-223



INCLUSO NEL  
MODELLO  
MONOFASE  
INCLUDED  
IN THE  
SINGLE-PHASE  
MODEL



INCLUSO NEI MODELLI  
MONOFASE  
INCLUDED IN THE  
SINGLE-PHASE MODELS

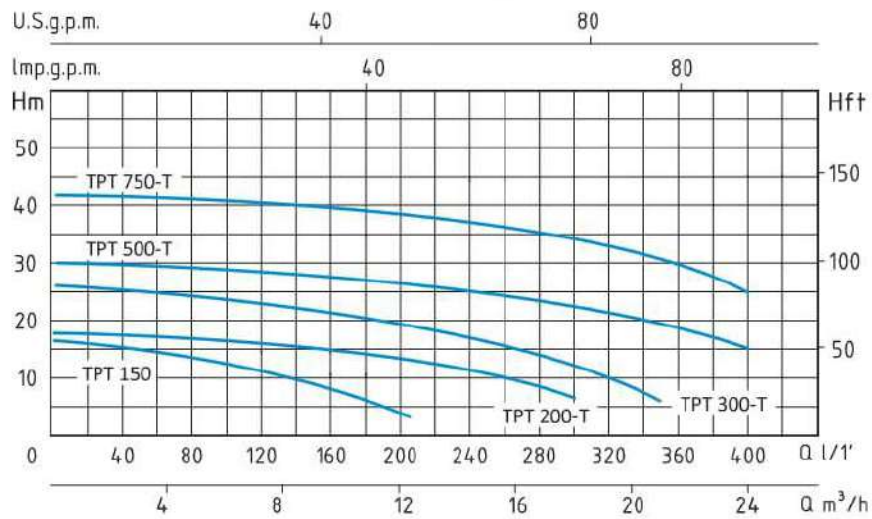

TPT - 50 HZ - 1 PHASE / 3 PHASE																
TIPO TYPE		POTENZA NOMINALE NOMINAL POWER		AMPERE		Q = PORTATA - CAPACITY										
Monofase Single-phase	Trifase Three-phase	P2		Monofase Single-phase	Trifase Three-phase	m³/h	0	3	6	9	12	15	18	21	24	27
		HP	kW			lt/1'	0	50	100	150	200	250	300	350	400	450
						Prevalenza manometrica totale in m.C.A. - Total head in meters w.c.										
TPT 150		1,5	1,1	6,5		H (m)	17	15	12	9	5					
TPT 200-T		2	1,5		3,7		18	17	16	15	13	10,5	7			
TPT 300-T		3	2,2		5,2		26,5	25,5	24,5	23	21	18	14	6		
TPT 500-T		5	3,7		8		30	29	28	27	25,8	24	22	19	15	9
TPT 750-T		7,5	5,5		11		42	41,4	41	40	39	38	36	33	25	10

#### APPLICAZIONI

Elettropompa con girante immersa di tipo multicanale aperta con sistema di triturazione in aspirazione.

Particolarmente indicata in presenza di lunghe fibre filamento-se o fibrose, di corpi solidi distruttibili anche di grandi dimensioni, nel trattamento di liquidi biologici e di acque di origine civile.

#### LIMITI D'IMPIEGO

- Temperatura liquido fino a 35°C (per un uso domestico secondo EN 60335-2-41)
- Temperatura max. liquido: 40°C (per altri impieghi)
- Massima profondità d'immersione 10 mt. (per un uso domestico secondo EN 60335-2-41)
- Livello min. d'aspirazione 125 mm
- Servizio continuo

#### MOTORE

- Monofase 230V-50Hz (con galleggiante)
- Trifase 230/400V-50Hz
- Isolamento Classe F
- Protezione IP 68
- Protettore termico
- Condensatore esterno (TPT 150)

#### MATERIALI

- Corpo motore
- Corpo pompa
- Girante
- Albero motore
- Trituratore
- Doppia tenuta meccanica in camera d'olio

Ghisa  
Ghisa  
Ghisa  
Acciaio Inox AISI 304  
Acciaio Inox AISI 304

Ceramica/Grafite/NBR  
Silicio/Silicio/NBR

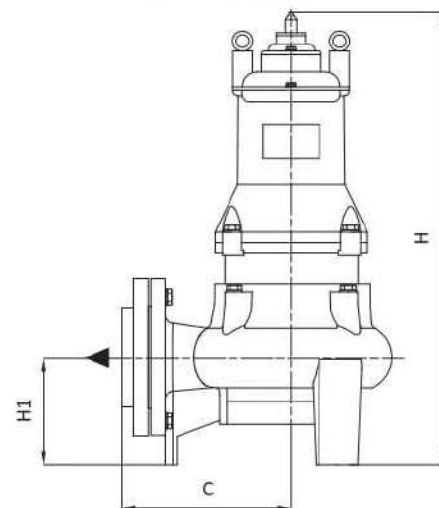
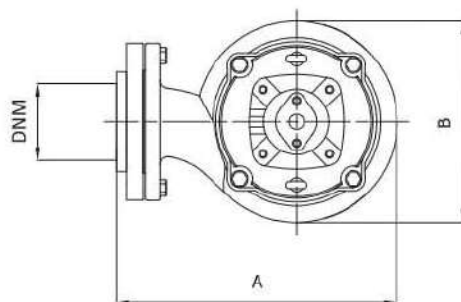

#### APPLICATION

Electric pump with plunged impeller, this impeller is multi-pipe, open, with a cutting system in the suction.

It is particularly suitable in presence of long, filamentous or fibrous fibres, of destroyable solids also of big dimensions and in biologic liquids or in civil waters.

#### OPERATING CONDITIONS

- Liquid temperature up to 35°C (for home use according to EN 60335-2-41)
- Temperature max. liquid: 40°C (for other uses)
- Maximum immersion depth 10 mt. (for home use according to EN 60335-2-41)
- Min. suction level 125 mm
- Continuous duty

#### MOTOR

- Single-phase 230V-50Hz (with floater)
- Three-phase 230/400V-50Hz
- Insulation Class F
- Protection IP 68
- Thermic protection
- External capacitor (TPT 150)

#### MATERIALS

- Motor body
- Pump body
- Impeller
- Shaft with rotor
- Cutting
- Double mechanical seal in oil chamber

Cast Iron  
Cast Iron  
Cast Iron  
Stainless Steel AISI 304  
Stainless Steel AISI 304

Ceramic/Graphite/NBR  
Silicon/Silicon/NBR

TIPO TYPE		DIMENSIONI mm- DIMENSIONS mm							DIMENSIONI DIMENSIONS mm			PESO WEIGHT
Monofase Single-phase	Trifase Three-phase	A	B	C	H	H1	DNM	CAVO CABLE	P	L	H	Kg
TPT 150		212	165	130	495	85	1"½	10 mt H07RNF	235	220	535	32
	TPT 200-T	245	200	150	525	90	1"½	10 mt H07RNF	240	285	630	38
	TPT 300-T	245	200	150	545	90	1"½	10 mt H07RNF	240	285	630	43
	TPT 500-T	255	205	155	610	100	2"	10 mt H07RNF	260	305	720	56
	TPT 750-T	270	220	160	635	100	2"	10 mt H07RNF	280	315	750	70