



Application

- Can be used to transfer clean water or other liquids similar to water in physical and chemical properties
- Suitable for pumping water from lake, river and well
- Industrial use and agricultural irrigation

Pump

- Cast iron pump body and support under special anti-rust treatment
- AISI 304 shaft
- Max. liquid temperature: +40°C
- Max. suction: 8 m

Motor

- C&U bearing
- Motor with copper winding
- Built-in thermal protector for single phase motor
- Insulation class: F
- Protection class: IPX4
- Max. ambient temperature: +40°C

Identification Codes

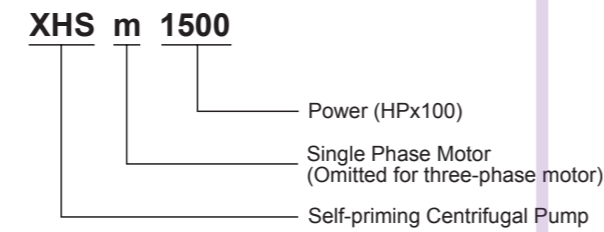

Hydraulic Performance Curves

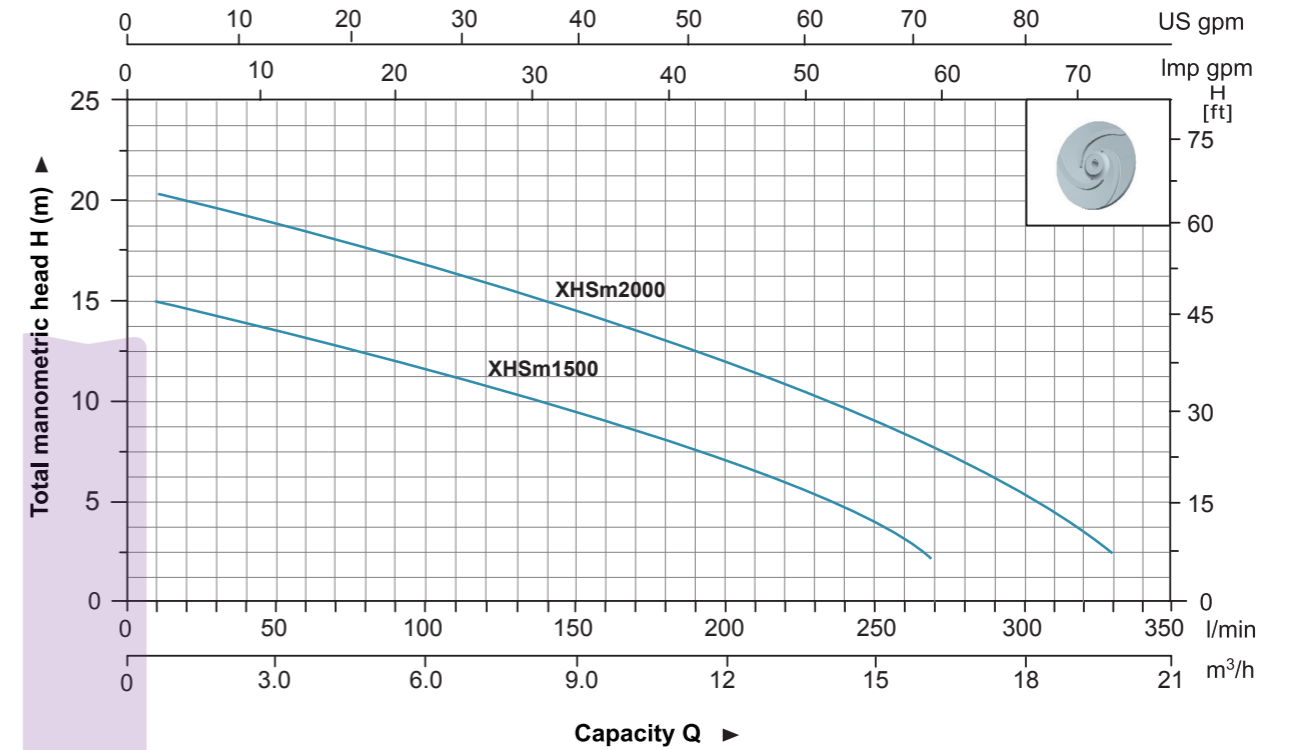

Technical Data

Model		POWER		Q (m³/h)																		
Single Phase	Three Phase	kW	HP	0	2.1	4.5	6.6	8.1	10.2	12	14.1	16.2	19.8									
				Q (l/min)	0	35	75	110	135	170	200	235	270	330								
XHSm1500	XHS1500	1.1	1.5	H (m)	15	14	12.5	11	10	8.5	7	5	2.5									
XHSm2000	XHS2000	1.5	2		20.5	19	17.5	16	15	13.5	12	10	7.5	2.5								

Materials Table

No.	Part	Material
1	Fan cover	08F
2	Fan	PP
3	Rear cover	ZL 102
4	Rotor	
5	Bearing	
6	Stator	
7	Support	HT200
8	Mechanical seal	Carbon/Ceramic
9	Impeller	HT200
10	Pump body	HT200
11	Inlet adaptor	HT200
12	Non-return valve	NBR
13	Capacitor	

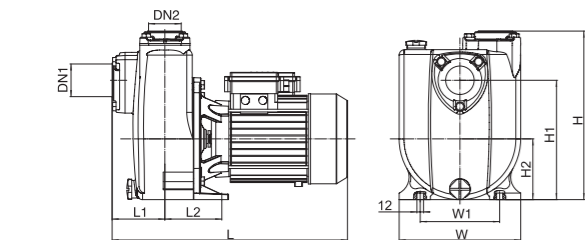
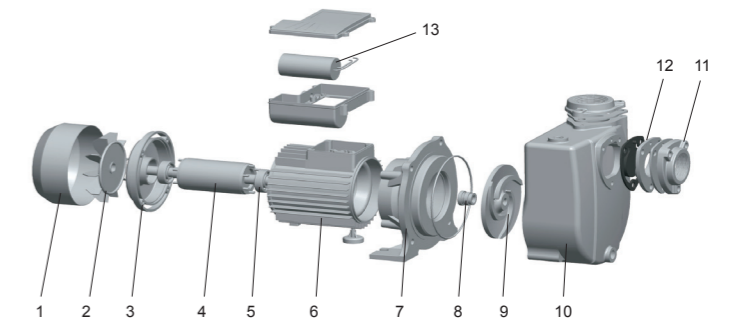

Dimension

Model	DN1	DN2	L (mm)	W (mm)	H (mm)	L1 (mm)	L2 (mm)	W1 (mm)	H1 (mm)	H2 (mm)
XHSm1500	2"	2"	430	222	308	96.5	104	145	218	111
XHSm2000										

Package Information

Model	GW (Kgs)	L (mm)	W (mm)	H (mm)	Quantity (PCS/20'TEU)
XHSm1500	34.5	475	280	380	580
XHSm2000	36.5	475	280	380	580

