



Application

- Can be used to transfer clean water or other liquids similar to water in physical and chemical properties
- Suitable for small living water supply, automatic water sprinkler system, small air conditioner system or supporting equipment etc.

Pump

- Special anti-rust treatment for cast iron pump body and support
- Anti-block system for impeller
- Brass impeller
- AISI 304 shaft
- Max. liquid temperature: +40°C
- Max. suction: +8 m

Motor

- C&U bearing
- Motor with copper winding
- Built-in thermal protector for single phase motor
- Insulation class: F
- Protection class: IPX4
- Max. ambient temperature: +40°C

Identification Codes

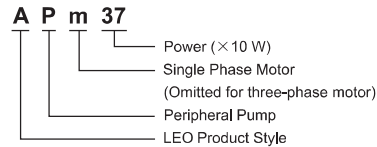

Technical Data

| MODEL | | POWER | | Q (m ³ /h) | | | | | | | | | | | | | | | |
|--------------|-------------|-------|-----------|-----------------------|-----|-----|-----|-----|-----|-----|-----|-----|-----|-----|-----|-----|-----|----|--|
| Single Phase | Three Phase | kW | HP | 0 | 0.3 | 0.6 | 0.9 | 1.2 | 1.5 | 1.8 | 2.1 | 2.4 | 3.0 | 3.6 | 4.2 | 4.8 | 5.4 | | |
| | | | Q (l/min) | 0 | 5 | 10 | 15 | 20 | 25 | 30 | 35 | 40 | 50 | 60 | 70 | 80 | 90 | | |
| APm30 | — | 0.3 | 0.4 | H (m) | 30 | 26 | 20 | 15 | 12 | 8 | 5 | 2 | - | - | - | - | - | | |
| APm37 | — | 0.37 | 0.5 | | 40 | 35 | 30 | 25 | 20 | 15 | 10 | 5 | 2 | - | - | - | - | - | |
| APm60 | — | 0.6 | 0.8 | | 60 | 55 | 50 | 40 | 35 | 30 | 25 | 20 | 10 | 5 | - | - | - | - | |
| APm75 | — | 0.75 | 1.0 | | 75 | 70 | 60 | 50 | 45 | 35 | 28 | 22 | 15 | 5 | - | - | - | - | |
| APm90 | — | 0.75 | 1.0 | | 90 | 75 | 60 | 50 | 35 | 25 | 15 | 5 | - | - | - | - | - | - | |
| APm110 | AP110 | 1.1 | 1.5 | | 85 | 80 | 75 | 65 | 60 | 55 | 50 | 45 | 40 | 30 | 18 | 10 | - | - | |
| APm150 | AP150 | 1.5 | 2.0 | | 90 | 86 | 80 | 75 | 70 | 65 | 60 | 55 | 50 | 40 | 30 | 20 | 10 | - | |
| — | AP220 | 2.2 | 3.0 | | 100 | 96 | 90 | 85 | 80 | 75 | 70 | 65 | 60 | 50 | 40 | 30 | 20 | 10 | |

Dimension

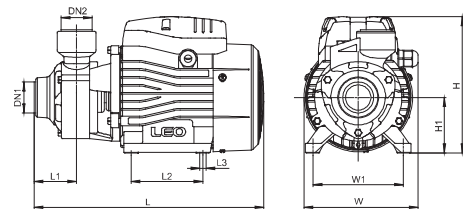

| MODEL | DN1 | DN2 | L (mm) | W (mm) | H (mm) | L ₁ (mm) | L ₂ (mm) | W ₁ (mm) | H ₁ (mm) | L ₃ (mm) |
|--------|------|------|--------|--------|--------|---------------------|---------------------|---------------------|---------------------|---------------------|
| APm30 | 1" | 1" | 260 | 132 | 155 | 46.5 | 80 | 100 | 63 | 8.5 |
| APm37 | | | 260 | 132 | 155 | 46.5 | 80 | 100 | 63 | 8.5 |
| APm60 | | | 282 | 147 | 183 | 51 | 90 | 112 | 71 | 8.5 |
| APm75 | | | 300 | 147 | 183 | 54.5 | 90 | 112 | 71 | 8.5 |
| APm90 | 3/4" | 3/4" | 289 | 147 | 183 | 50 | 90 | 112 | 71 | 8.5 |
| APm110 | 1" | 1" | 336 | 165 | 210 | 56 | 100 | 125 | 86 | 9 |
| APm150 | | | 338 | 165 | 210 | 56 | 100 | 125 | 86 | 9 |
| AP220 | | | 338 | 165 | 210 | 56 | 100 | 125 | 86 | 9 |

Hydraulic Performance Curves

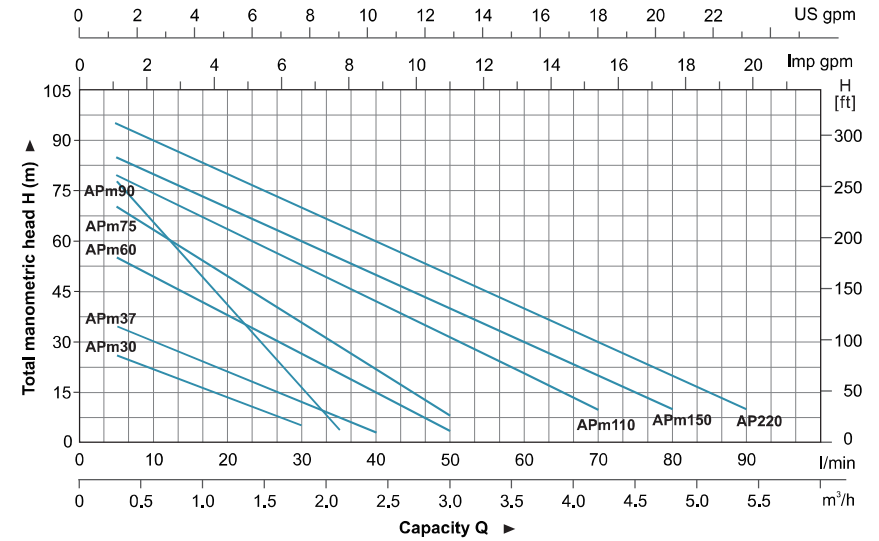

Materials Table

| No. | Part | Material |
|-----|-----------------|----------------|
| 1 | Pump body | HT200 |
| 2 | Impeller | Brass |
| 3 | Mechanical seal | Carbon/Ceramic |
| 4 | O-ring | NBR |
| 5 | Support | HT200 |
| 6 | Bearing | |
| 7 | Rotor | |
| 8 | Fan cover | PP |
| 9 | Fan | PP |
| 10 | Rear cover | ZL102 |
| 11 | Capacitor | |
| 12 | Terminal box | ABS |
| 13 | Terminal board | PC |
| 14 | Stator | |
| 15 | Filling plug | HPB59-1 |

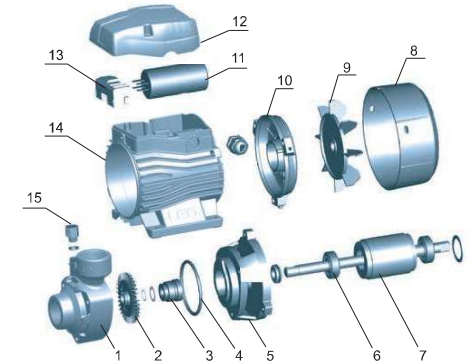

Package Information

| Model | GW (Kgs) | L (mm) | W (mm) | H (mm) | Quantity (PCS/20 TEU) |
|--------|----------|--------|--------|--------|-----------------------|
| APm30 | 5.1 | 283 | 158 | 171 | 3132 |
| APm37 | 5.5 | 283 | 158 | 171 | 3132 |
| APm60 | 9.0 | 315 | 190 | 210 | 2365 |
| APm75 | 10.5 | 335 | 190 | 210 | 2222 |
| APm90 | 10.5 | 335 | 190 | 210 | 2222 |
| APm110 | 15.9 | 370 | 210 | 235 | 1230 |
| APm150 | 16.5 | 370 | 210 | 235 | 1230 |
| AP220 | 17.2 | 370 | 210 | 235 | 1230 |

